

Modify the Universal Holder

The original pins on the Universal Holder (T/N 07725-0030000) are too short to completely engage the holes in a power steering pump pulley. To improve this tool, press out the original pins, and install an 8 x 30 mm bolt into each hole.

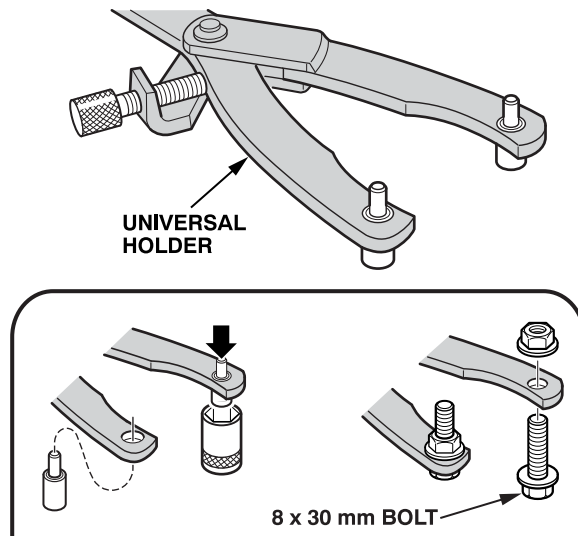

Power Steering Fluid Foams at Reservoir

On all Hondas with power steering, a pin hole leak between the reservoir and the suction (inlet) side of the pump can cause the power steering fluid in the reservoir to foam and overflow. When air is sucked into the system, it mixes with the fluid and causes it to foam. This foaming can also cause the pump to growl. Pin hole leaks are hard to diagnose because they let air in but they don't leak fluid out. So, if you suspect a pin hole leak, try this:

1. Start the engine, and let it warm up to operating temperature.
2. Adapt a hand pump to fit into the reservoir opening. (If you're using a Mighty-Vac pump, it comes with adapters to do this.)
3. With the engine idling, connect the hand pump to the reservoir, and pressurize the reservoir to a maximum of 8 psi.
4. Look for a leak in the suction (inlet) hose or at the pump seal. Repair the power steering system as needed.

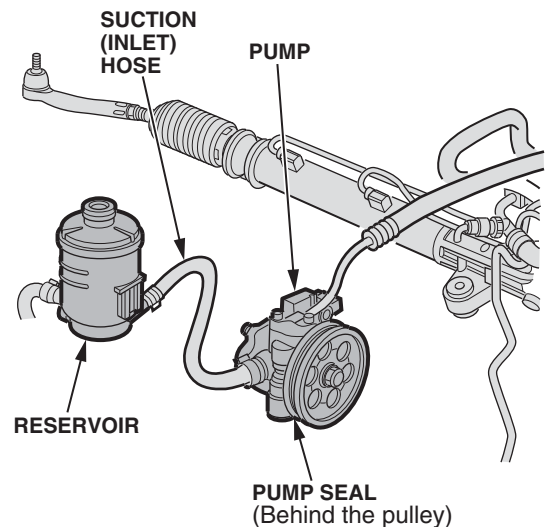

'01 Civic PCM PUD Q & A

The recently released S/B 00-098, *2001 Civic Product Update: Powertrain Control Module*, filed under Fuel and Emissions, has generated a number of calls to Tech Line. Here are the most frequently asked questions and the answers to each:

Question: *How do I determine if the vehicle has 49-state or California emissions?*

Answer: Refer to step 7, which says to use the last three digits of the old PCM part number. If the suffix begins with an **A**, the vehicle has 49-state emissions; if the suffix begins with an **L**, the vehicle has California emissions.

Question: *I replaced the PCM, but the MIL came on with DTC P0141. What's going on?*

Answer: This S/B applies *only* to '01 Civic DXs and LXs. If you install the updated PCM in an EX model, the MIL will come on with a DTC P0141 [secondary HO2S (sensor 2) heater circuit malfunction], and you will have wasted your time.

Use Correct Temp Gauge in '01 Odyssey

When replacing a temperature gauge in a '01 Odyssey, you *must* replace it with one for a '01 model. If you replace it with one for a '99-00 model, the indicator needle will stick in the middle of the gauge range. That's because the temperature gauges for '99-00 and '01 models work differently. The gauge for '99-01 models is controlled by a separate ECT sensor; the gauge for '01 models is controlled by the PCM.

Climate Control Temperature Display Accuracy

On Honda vehicles with a climate control system, the displayed temperature and the actual temperature inside the vehicle may *not* be the same. Here are the most common reasons why:

- If the climate control system is in the semi-automatic mode, the system may *not* be able to select the proper mix of conditioned and/or heated air, blower speed, and recirculation to reach the target temperature.
- When driving in the direction of the sun, the sunlight sensor in the top of the dashboard compensates for the added heat from direct sunlight and lowers the temperature inside the vehicle accordingly.
- If the temperature control dial is set to its lower limit (60° F) or its upper limit (90° F), the climate control system runs at full cooling or heating only. It does *not* regulate the temperature inside the vehicle.
- In cold weather, the fan will *not* come on automatically until the engine coolant is warm enough for the heater to blow warm air.
- The display temperature and the vent temperatures rarely match. When the outside temperature is *colder* than the target temperature, the vent temperatures will be *warmer* to compensate for heat loss. When the outside temperature is *warmer* than the target temperature, the vent temperatures will be *colder* to compensate for heat gain from the engine and through the glass.
- The airflow from an automobile climate control system feels cooler at a given temperature than the airflow from a residential/commercial heating/cooling system because the climate control system blows the air directly on the passengers. Airflow from the dashboard vents removes body heat faster than the gentle airflow from a residential/commercial heating/cooling system.

If you need additional information about the climate control system, refer to the appropriate owner's manual.

Low Fuel Indicator Doesn't Come On: '97-00 CR-V

On '97-00 CR-Vs, if the low fuel indicator doesn't come on at all or it doesn't come on at the fuel level where it used to come on, replace the fuel gauge sending unit.

TCS Operation Explained

On '99-00 Odyssey Ex, and all '01 Odysseys and Accord V6s, the traction control system (TCS) limits wheel spin when starting out or driving slowly on slippery road surfaces. The TCS works *only* in low-speed, low-traction conditions, up to about 18 mph.

The TCS monitors the speed of all four wheels. When it senses one of the drive wheels losing traction and starting to spin, it applies braking to that wheel to slow it down. The TCS indicator on the instrument panel blinks when this happens.

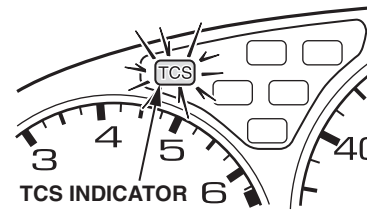

When the TCS is on, you may notice that the vehicle doesn't respond to the accelerator pedal like it does at other times. The TCS helps control engine speed to prevent damage to the transmission. It also applies the brakes to transfer power to the wheel that has traction.

Driving with the compact spare tire mounted may turn on the TCS. You should *always* turn off the TCS when using the compact spare tire.

If the brakes overheat while the TCS is on, the TCS indicator stops blinking and stays on temporarily. This tells you the TCS is *off*. After the brakes have cooled down (usually about 10 minutes), the TCS comes on again and the TCS indicator goes out.

The TCS ON/OFF switch under the driver's side vent lets you turn the TCS off and on. When you press the switch, the TCS is *off* and the TCS indicator comes on as a reminder. When you press the switch again, the TCS is *on*, and the indicator goes off. You *cannot* turn off the TCS while the TCS indicator is blinking.

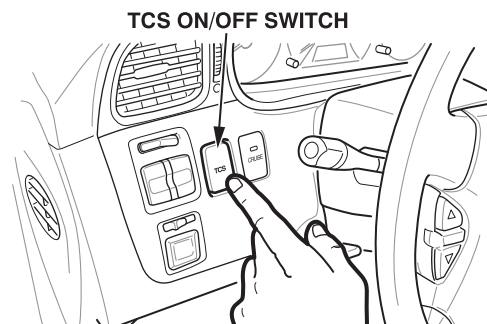

The TCS automatically comes on every time you start the engine, even if you turned the system off the last time you drove the vehicle. For additional info on the TCS, refer to the appropriate owner's manual.

A/C Compressor Mounting Bolts: '01 Civic

In step 17 of the '01 Civic A/C installation instruction (AII 21888-22262), you must remove the A/C compressor bracket to install the heat insulator. Three of the A/C compressor bolts are 10 x 45 mm and one is 10 x 35 mm. When you reinstall the compressor bracket, make sure you reinstall the 10 x 35 mm bolt in the *lower right* bolt hole in the bracket. If you install one of the longer 10 x 45 mm bolts in that hole, the bolt head will damage the compressor.

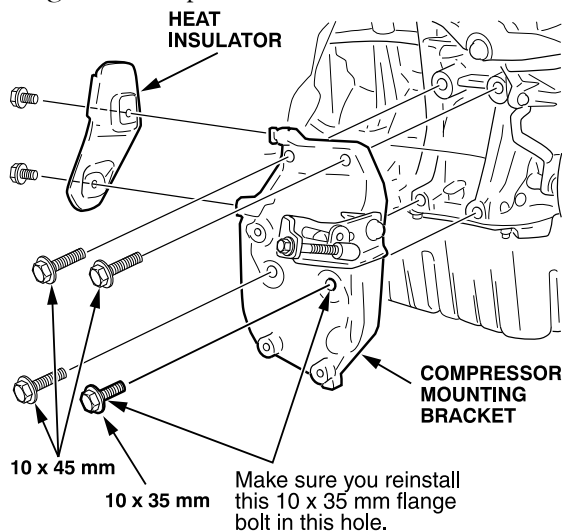

~~A/T Shift Complaints? Check Clutch Pressure Switches~~

NOTE: This condition can affect '98-01 Accords, '97-01 Preludes, and '98-01 Odysseys.

Shift quality complaints such as harsh or late upshifts and downshifts don't always mean you need to replace the A/T. They're often caused by the 2nd and 3rd clutch pressure switch circuits being open or shorted to ground. To confirm the problem, connect the PGM Tester, and check if DTC P1738 (problem in 2nd clutch pressure switch) or DTC P1739 (problem in 3rd clutch pressure switch) is set. These two DTCs do not cause the D4 indicator to blink and do not cause the MIL to come on.

This article is replaced by A08070I in the July '08 issue

Fuel Tank Capacity in '01 Civics

Some early 2001 Civic Owner's Manuals incorrectly show the fuel tank capacity to be 11.9 U.S. gallons. The *correct* fuel capacity is **13.2** U.S. gallons.

Power Sliding Door Latch Torque: '99-01 Odyssey EX

When you're doing S/B 00-047, *Safety Recall: Rear Door Latch Assembly*, filed under Body, make sure you use an accurate inch-pound torque wrench to torque the six door latch assembly mounting bolts to 6 N·m (4.5 lb-ft, which is 54 lb-in).

Overtightening these bolts can squeeze the latch and keep the door from latching properly. When the door does *not* latch, the appropriate indicator in the door and brake lamp monitor comes on and the beeper sounds.

Variable Intermittent Wipers Are Speed Sensitive

On '98-01 Accord EXs and LXs, and '99-01 Odysseys, the variable intermittent wipers are speed-sensitive. As with the variable intermittent wipers in other Honda models, you can set the rotary switch to three settings: intermittent, low speed, and high speed. In the low speed and high speed settings, the wipers sweep the windshield continuously. But in the intermittent setting, the wipers work like this:

- The wipers make one sweep every few seconds when you're driving over 12 mph.
- When you're stopped, or driving under 12 mph with the brakes applied, the sweep delay increases by about 4 seconds.
- When you release the brakes, the wipers make one sweep to give you a clear view of the road. Once the vehicle reaches 12 mph, the wipers go back to their preset sweep frequency.
- When you're driving over 12 mph with the INT TIME ring next to the rotary switch turned to its shortest delay, the wipers switch to low speed.

IMA Battery and Long Term Storage: '00-01 Insight

On '00-01 Insights, the IMA battery needs periodic charging to ensure maximum performance and longevity. This is particularly important if the vehicle is sitting on a dealer's lot or is in long term storage. To charge the battery, remove the No. 15 (40 A) fuse from the underhood fuse/relay box. Start the engine, increase the engine speed to 3,500 rpm, and hold it there until the battery level gauge on the instrument panel reads fully charged. When you're finished, turn off the engine, and reinstall the fuse. This procedure should take you less than 10 minutes.

Battery Level Gauge Operation: '00–01 Insight

The '00–01 Insights use a high voltage (144 V) nickel-metal hydride battery to store energy for the IMA system. The IMA battery is used to start the engine and to assist it when accelerating. Energy is returned to the IMA battery at other times.

The battery level gauge on the instrument panel indicates a calculated value of the available energy stored in the IMA battery. This calculation is based on measurements of these parameters: the current entering and leaving the battery, the battery voltage, and the battery temperature. Over time, small, cumulative errors in measuring these parameters can cause the gauge to indicate a higher level of available energy than is actually stored in the IMA battery. When the error is great enough, the gauge corrects itself.

You can tell when the gauge makes a self-correction because the gauge indicates a drop to zero charge or it indicates a zero charge. Here are the most common situations where you can see this happen:

- You drive up a hill and park the vehicle overnight. When you start the engine the next morning, the gauge will indicate a zero charge.
- You drive up a long or steep hill or accelerate from a low speed in 5th gear, placing an extended, constant demand on the IMA system. You'll notice the IMA charge/assist gauge on the instrument panel indicates a drop from full assist to no assist (no indication), but the battery level gauge still indicates some level of charge in the battery. Several seconds later, the gauge indicates a drop to zero charge. And if you happen to turn off the ignition switch *before* the gauge indicates a drop to zero charge, the gauge will indicate a zero charge when you turn the ignition switch ON (II) again. This happens because the battery control system keeps monitoring and updating for several seconds after the ignition switch is turned off.

After the gauge corrects itself, the IMA system goes immediately into a charge mode, and the IMA battery is recharged. The Auto Idle Stop function is disabled while the battery is in this low state of charge. However, a few minutes of normal driving will restore normal IMA operation.

These corrections to the battery level gauge are considered normal. If the IMA battery develops a problem or it becomes deteriorated, the IMA system will turn on the IMA system indicator on the instrument panel.

ABS DTC 1-8: '94–97 Accord, '95–97 Odyssey

On '94–97 Accords and '95–97 Odysseys, when the ABS self-test detects a faulty accumulator, the ABS control unit sets a DTC 1-8 (accumulator volume problem). Before you replace any ABS components, do these steps first:

1. Bleed the high-pressure brake fluid from the modulator unit (see the ABS section of the appropriate service manual). Measure the quantity of brake fluid collected when the system pressure is relieved.
 - If the accumulator gas pressure is *zero*, you'll collect about 5 cc of fluid.
 - If the accumulator gas pressure is *low*, you'll collect up to 75 cc of fluid.
 - If the accumulator gas pressure is *OK*, you'll collect 35 to 45 cc of fluid.

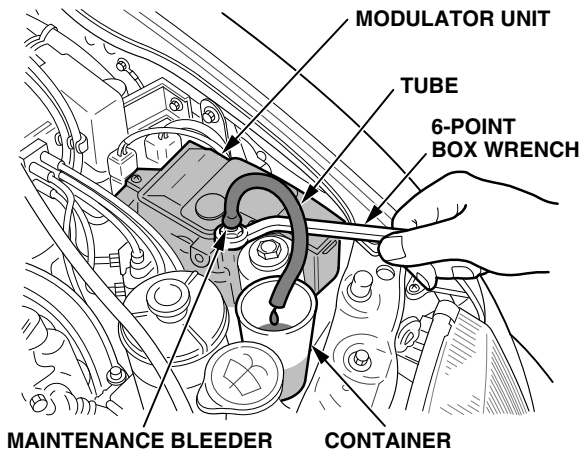

2. If the accumulator contains less than 35 cc or more than 45 cc of fluid, refer to S/B 93-038, *ABS Light Comes On*, filed under Steering/Brakes/Suspension, and carefully bleed the system.
3. Remeasure the accumulator fluid volume. If the accumulator fluid volume is *still* not within 35 cc to 45 cc after bleeding, replace the accumulator.

Long Crank Time at Cold Startup: '96–00 Civic

On '96–00 Civics, a low fuel level can cause a long crank time. To test the crank time, use a stopwatch or the PGM Tester, and make sure the fuel tank is at least 1/2 full. A cold start crank time of up to 2 seconds is normal. With the fuel tank close to empty, the crank time will be even longer.

S/M Fix: SRS Simulator Lead H, '01 Civic

The SRS Simulator Lead H (T/N 07YAZ-S3A0100), called out in the Restraints section of the '01 Civic S/M, has been replaced by the SRS Simulator Lead G (T/N 07YAZ-S3AA100). Make these changes in your copies of the S/M:

Page 23-2, Special Tools table: Change the tool number entry for Ref. No. 8 to read "07YAZ-S3AA100." Change the description entry for Ref. No. 8 to read "SRS Simulator Lead *G*."

Page 23-87, step 15: Change the SRS simulator lead callout in the illustration to read: "07YAZ-S3AA100."

Page 23-90, step 15: Change the SRS simulator lead callout in the illustration to read: "07YAZ-S3AA100."

Page 23-103, step 6: Change the SRS simulator lead callout in the illustration to read: "07YAZ-S3AA100."

S/M Fix: DTC P0138 on '01 Civic

On page 11-72 of the '01 Civic S/M, the "NO" response in step 12 of the troubleshooting procedure for DTC P0138 [secondary HO2S (sensor 2) circuit high voltage] should read: "Repair *open* in the wire . . ."

S/M Fix: Camber Adjusting Bolt P/N, '99-01 Odyssey

On page 18-6 of the '99-01 Odyssey S/M, the camber adjusting bolt has the wrong P/N. The *correct* P/N is *90120-S0X-A00*.

S/M Fix: DTC P0325 on '01 Civic

On page 11-83 of the '01 Civic S/M, the query in step 11 of the troubleshooting procedure for DTC P0325 (knock sensor circuit malfunction), should read: "Is there *continuity*?"

S/M Fix: Valve Body Replacement, '01 Civic

The Automatic Transmission section of the '01 Civic S/M calls out washers for the detent arm shaft. There are *no* washers used for the detent arm shaft in '01 Civics. Make these changes in your copies of the S/M:

Pages 14-144 and 14-174: Change the Exploded Views to look like this:

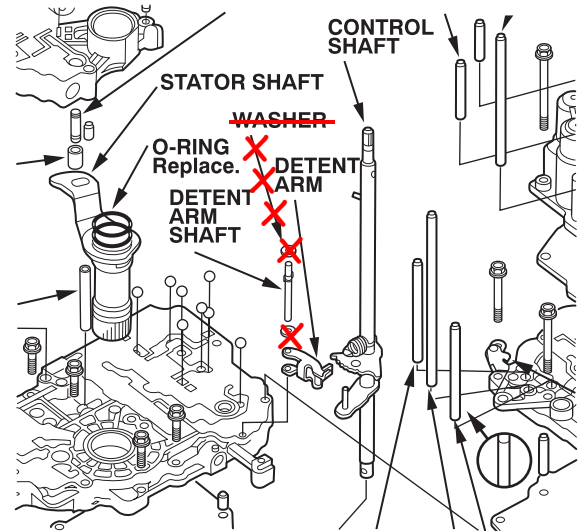

Page 14-145, step 10: Change it to read "Unhook the detent spring from the detent arm, then remove the detent arm shaft, the detent arm, and the control shaft."

Page 14-175, step 5: Change the illustration to look like this:

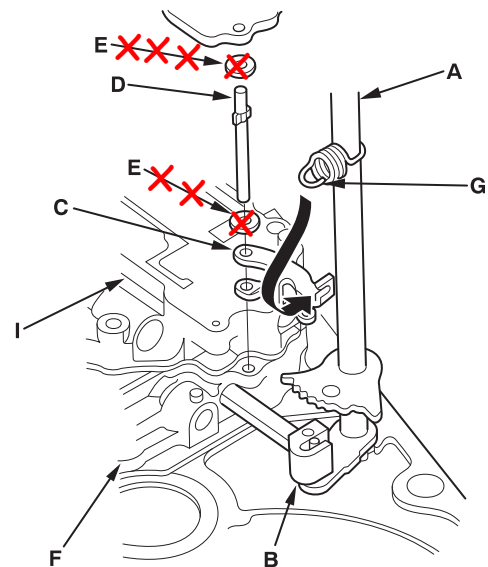

Page 14-175, step 6: Change it to read "Install the detent arm (C) and the detent arm shaft (D) in the main valve body (F), then hook the detent arm spring (G) to the detent arm."

S/M Fix: Damper/Spring Replacement, '01 Civic

In the '01 Civic S/M, step 1 on page 18-22 and on page 18-23 has the wrong orientation for the upper spring seat. Make these changes in your copies of the S/M:

Page 18-22, Reassembly, step 1: Change the text and illustration to read and look like this:

The hole in the upper spring seat and the arrow on the damper mounting base must point toward the knuckle mounting area.

Reassembly

1. Install all the parts except the self-locking nut onto the damper unit by referring to the Exploded View. Align the bottom of the spring (A) and the stepped part of the lower spring seat (B) as illustrated. ~~Align the upper spring seat so that the small hole in it is on the engine compartment side when it is installed in the body.~~

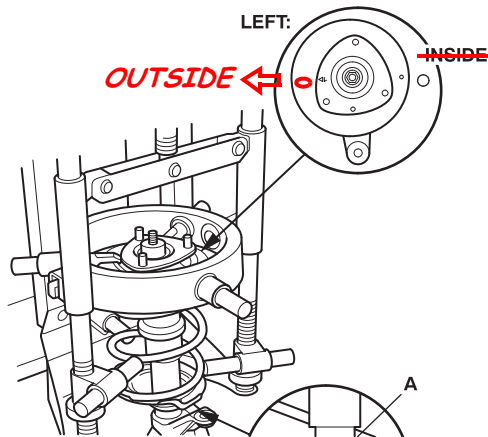

Page 18-23, Installation, step 1: Change the illustration to look like this:

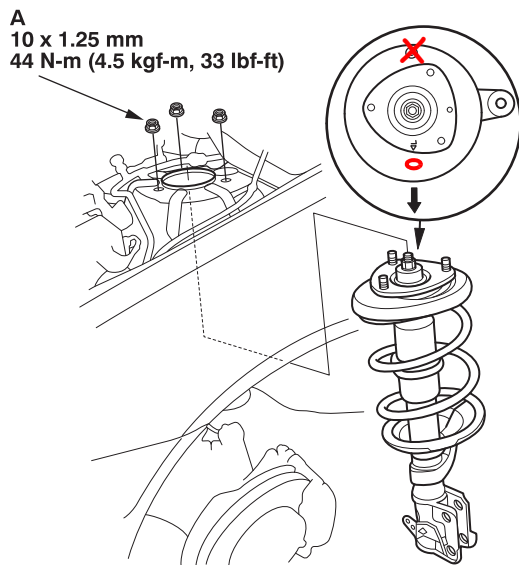

Civic '01 S/M Fixes: Restraints Troubleshooting

The Restraints section of the '01 Civic S/M has the wrong fuse number called out in the driver's under-dash fuse/relay box. The No. 19 (7.5 A) fuse should be No. **10** (7.5 A). Make sure you include these changes in your copies of the S/M:

Page 23-32: Change the circuit diagram to look like this:

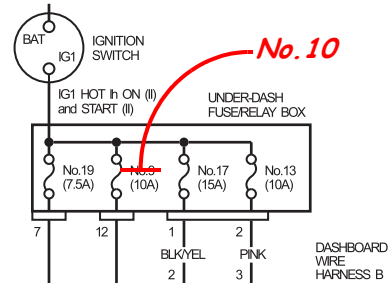

Page 23-78, step 4: Change it to read "Check the No. **10** (7.5 A) fuse . . ."

Page 23-113, step 7: Change it to read like this:

7. Check the No. ~~19~~¹⁰ (7.5A) fuse in the under-dash/fuse/relay box.

Is the fuse OK?

YES - Go to step 8.

NO - Short to ground in the No. ~~19~~¹⁰ (7.5A) fuse circuit. ■

Page 23-120, step 8: Change it to read like this:

8. Turn the ignition switch OFF. Check the No. ~~19~~¹⁰ (7.5A) fuse in the under-dash fuse/relay box.

Did fuse No. ~~19~~¹⁰ (7.5A) blow?

YES - Go to step 11.

NO - Go to step 9.

Page 23-121, steps 10 and 11: Change the "NO" responses to read ". . . in the under-dash fuse/relay box No. **10** (7.5 A) . . ."

HONDA ServiceNews

©2001 American Honda Motor Co., Inc. - All Rights Reserved. Published by AHM Service Communications, 1919 Torrance Blvd., Torrance, CA 90501-2746. All suggestions become the property of American Honda Motor Co., Inc.; sending a suggestion gives Honda permission to publish it without further consideration.



ASN 22447-40074 (0808)