



# Technical Service BULLETIN

February 16, 2006

Title:

## STEERING INTERMEDIATE SHAFT NOISE

Models:

'03 – '06 Camry, '04 – '05 Highlander, & '04 – '06 Solara,

REVISSED  
ST001-06  
STEERING

### TSB REVISION NOTICE:

- July 20, 2006: 2004 – 2005 model year Highlander vehicles have been added to Applicable Vehicles. Production change effective VINs for the Highlander have been added to the Production Change Information table. The Parts Information has been updated to include the Highlander.

Previous versions of this TSB should be discarded.

### Introduction

Some customers may hear a clunk, pop, or knock type noise when turning the steering wheel left or right. A new intermediate shaft has been developed to address this concern.

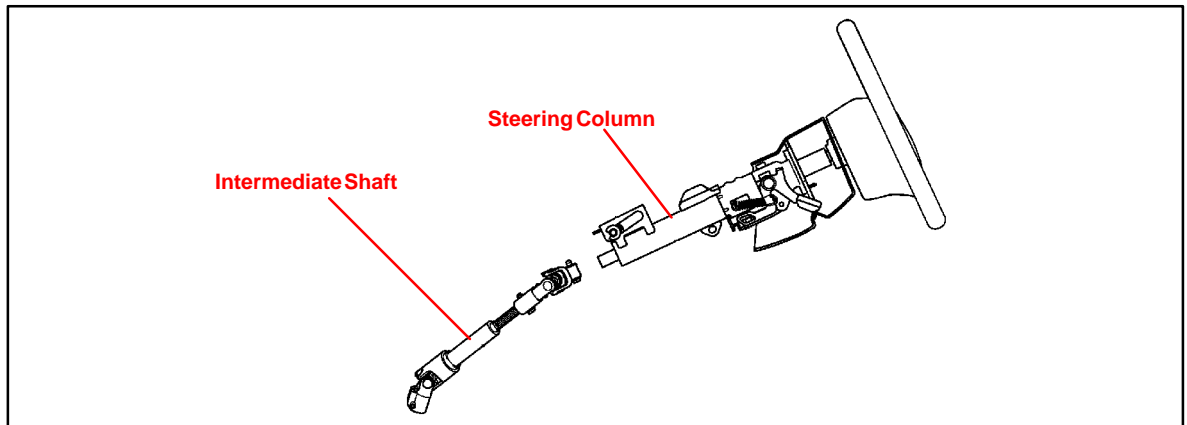

### Applicable Vehicles

- 2003 – 2006 model year **Camry** vehicles produced **BEFORE** the Production Change Effective VINs shown in this TSB.
- 2004 – 2005 model year **Highlander** vehicles produced **BEFORE** the Production Change Effective VINs shown in this TSB.
- 2004 – 2006 model year **Solara** vehicles produced **BEFORE** the Production Change Effective VINs shown in this TSB.

### Warranty Information

OP CODE	DESCRIPTION	MODEL	TIME	OFP	T1	T2
ST4007	R & R Steering Intermediate Shaft	Camry	0.9	45220-33200	91	19
		Solara	0.9	45220-33240		
		Highlander	0.9	45220-48130		

### Applicable Warranty\*:

This repair is covered under the Toyota Comprehensive Warranty. This warranty is in effect for 36 months or 36,000 miles, whichever occurs first, from the vehicle's in-service date.

\* Warranty application is limited to correction of a problem based upon a customer's specific complaint.



**Production  
Change  
Information**

MODEL	PLANT	ENGINE	PRODUCTION CHANGE EFFECTIVE VIN	
Camry	Tsutsumi	4-cyl	JTDBE3#K#53040321	
		V6	JTDBF3#K#50167507	
			JTDBA3#K#50026148	
	TMMK	4-cyl	4T1BE3*K#6U149463	
			4T1BE3*K#6U718586	
		V6	4T1BF3*K#6U118180	
			4T1BA3*K#6U510905	
			4T1BF3*K#6U632175	
			4T1BA3*K#6U093077	
Highlander	TMK	4-cyl	JTEDD21A#50131436	
			JTEGD21A#50131439	
			JTEED21A#50039951	
			JTEHD21A#50039951	
		V6	JTEDP21A#50090114	
			JTEGP21A#50090107	
			JTEEP21A#50134778	
		JTEHP21A#50134927		
	Solara	TMMK	4-cyl	4T1CE3*P#6U718267
			V6	4T1*A3*P#6U093577

**Parts  
Information**

PREVIOUS PART NUMBER	CURRENT PART NUMBER	MODEL	PART NAME	QTY
45220-33200	45220-33260	Camry	Intermediate Shaft Assembly	1
45220-33240		Solara		1
45220-48130		Highlander		1

**NOTE:**

The intermediate shaft assembly identified in this TSB for Camry models can be used on both Japan and NAP built vehicles.

**Repair Procedure**

Prior to removing the steering intermediate shaft, make sure the steering wheel and front wheels remain stationary. Once the intermediate shaft is removed, do NOT allow the steering wheel to spin freely.

**NOTE:**

Ensure the wheels are straight and the steering wheel is centered before removing the steering intermediate shaft sub-assembly by installing a steering wheel holder.

1. Disconnect the steering intermediate shaft sub-assembly.

- A. Loosen the bolt and remove the clamp from the steering column hole cover boot.
- B. Separate the steering column hole cover from the steering column hole cover boot.

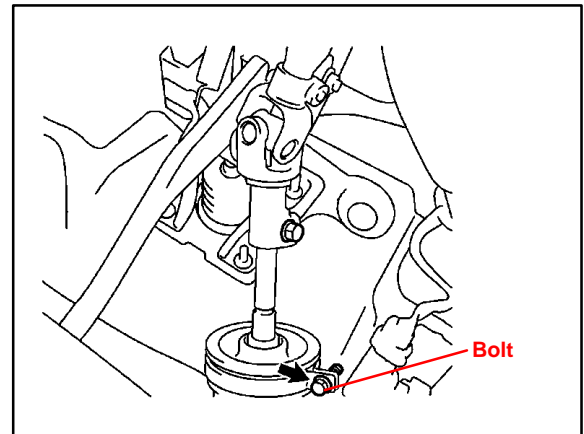

- C. Place matchmarks on the steering intermediate shaft sub-assembly and steering gear assembly.
- D. Remove the bolt and disconnect the steering intermediate shaft sub-assembly.

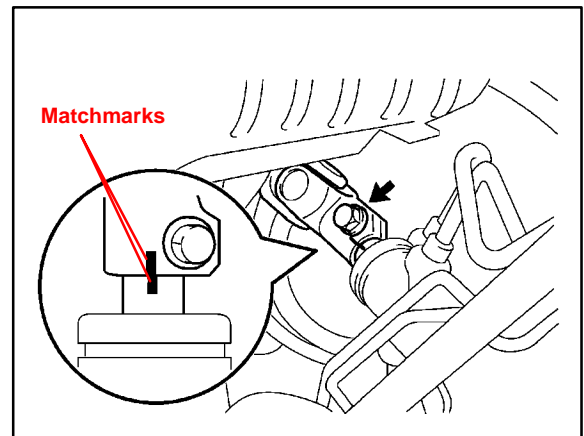

2. Remove the steering intermediate shaft sub-assembly.

- A. Place matchmarks on the steering sliding yoke sub-assembly and steering main shaft assembly.
- B. Remove the bolt and steering sliding yoke sub-assembly from the steering main shaft assembly.

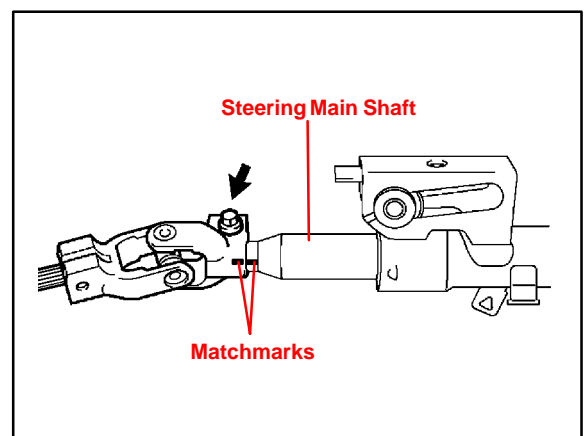

**Repair Procedure**  
(Continued)

3. Place the corresponding matchmarks on the NEW steering intermediate shaft sub-assembly.

To place the matchmarks on the NEW steering intermediate shaft sub-assembly, place a NEW steering intermediate shaft next to the original steering intermediate shaft assembly (removed in the previous step) and transfer those matchmarks to the same locations on the NEW steering intermediate shaft.

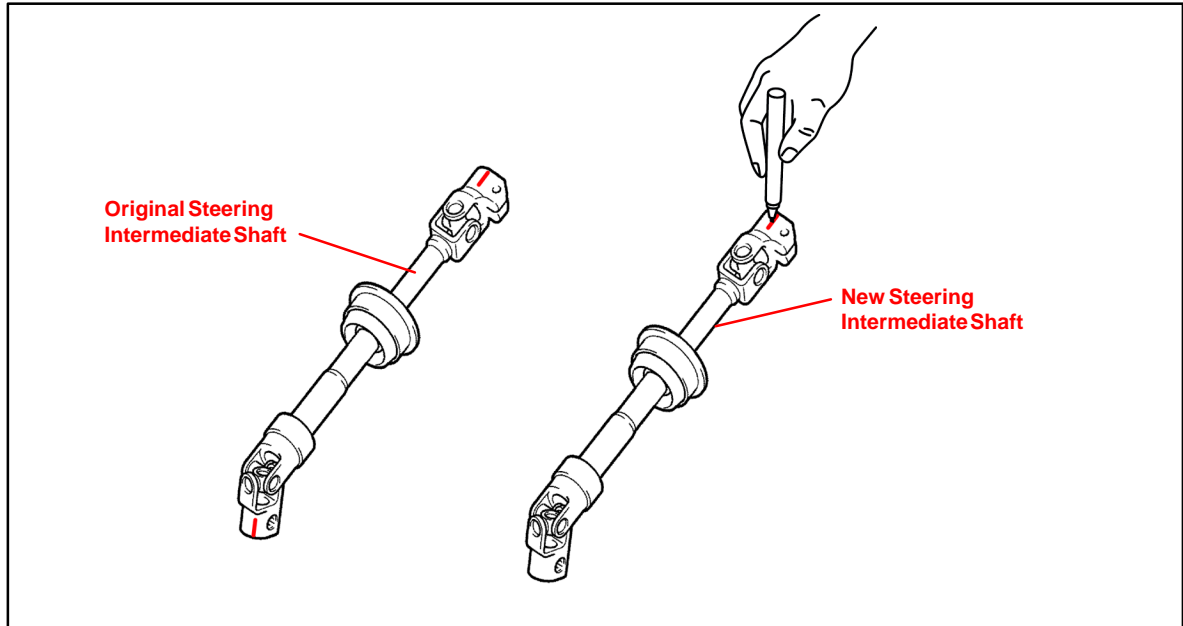

4. Install the NEW steering intermediate shaft sub-assembly.

- A. Align the matchmark with the one on the steering sliding yoke sub-assembly and the steering main shaft assembly.
- B. Install the steering sliding yoke sub-assembly with the bolt.

**Torque: 35.3 N•m (360 kgf•cm, 26 ft•lbf)**

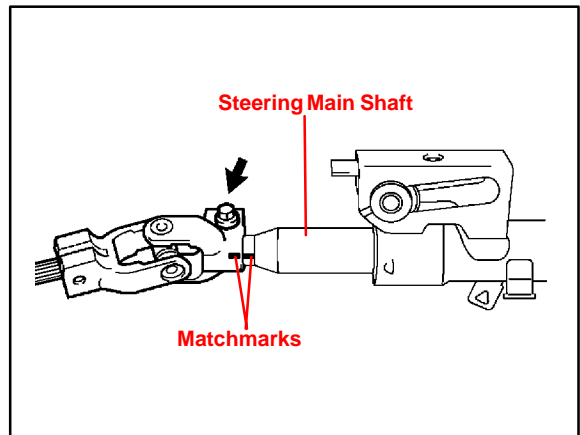

5. Connect the steering intermediate shaft sub-assembly.

- A. Align the matchmarks on the steering intermediate shaft sub-assembly and the steering gear assembly.
- B. Install the steering intermediate shaft sub-assembly with the bolt.

**Torque: 35.3 N•m (360 kgf•cm, 26 ft•lbf)**

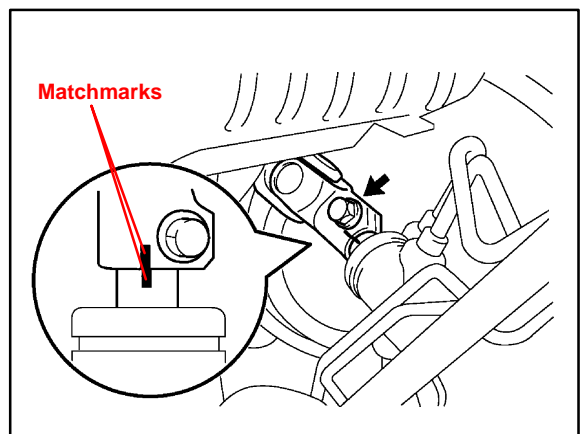

**Repair  
Procedure**  
(Continued)

- C. Install the steering column hole cover to the steering hole cover boot.
  - D. Connect the clamp to the steering column hole cover boot and tighten the bolt.
6. Remove the steering wheel holder from the vehicle (if used).
  7. Road test the vehicle to verify the repair and confirm that the steering wheel is centered.

