

[Select Vehicle](#) | [New TSBs](#) | [Technician's Reference](#)

Component Search:

OK

[Conversion Calculator](#)**1998 Subaru Legacy Outback AWD F4-2.5L DOHC**[Vehicle Level](#) → [Engine, Cooling and Exhaust](#) → [Engine](#) → [Oil Pan](#) → [Service and Repair](#) ←**Service and Repair**[Notes](#)**REMOVAL**

- 1) Remove front wheels.
- 2) Remove air intake duct.

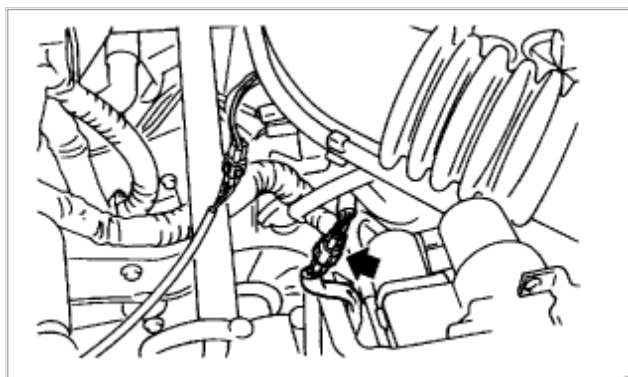

Zoom

Sized for Print

- 3) Disconnect connector from front oxygen sensor.

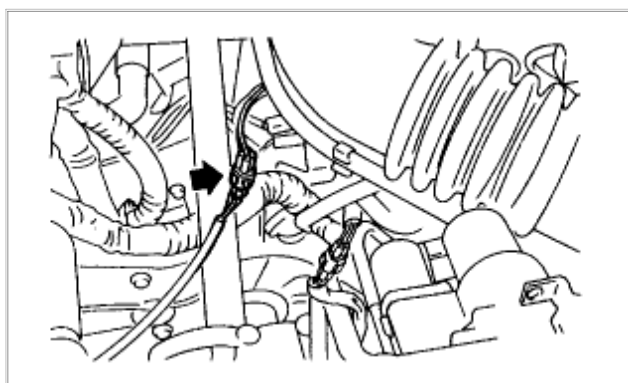

Zoom

Sized for Print

- 4) Disconnect connector from rear oxygen sensor, (California 2200 cc model only)

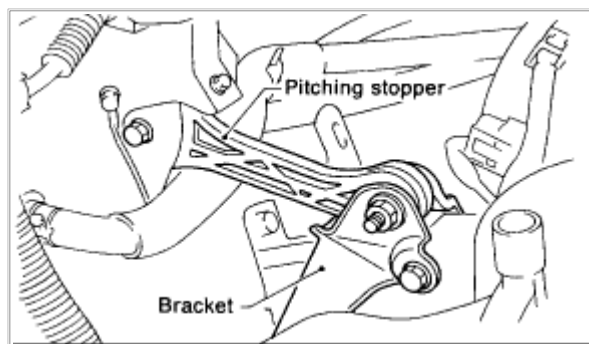

Zoom

Sized for Print

- 5) Remove pitching stopper.

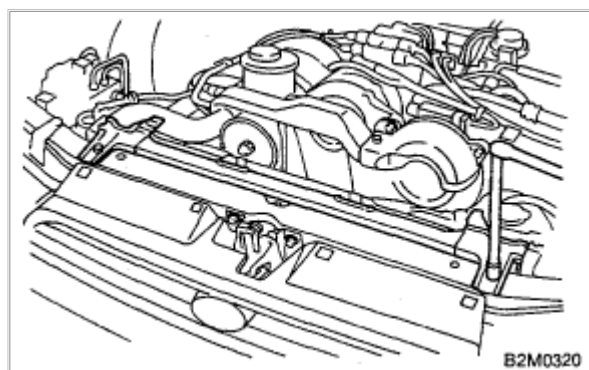

Zoom

Sized for Print

- 6) Remove [radiator](#) upper brackets,

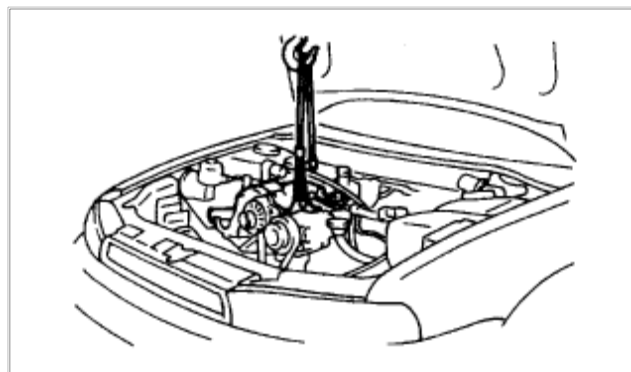

[Zoom](#)[Sized for Print](#)

- 7) Support engine with a lifting device and wire ropes.
- 8) Lift-up the vehicle.

CAUTION: At this time, raise up wire ropes.

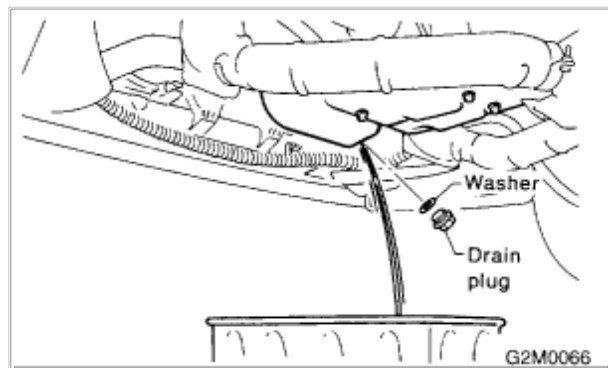
[Zoom](#)[Sized for Print](#)

- 9) Drain engine oil.
Set container under the vehicle, and remove drain plug from oil pan.

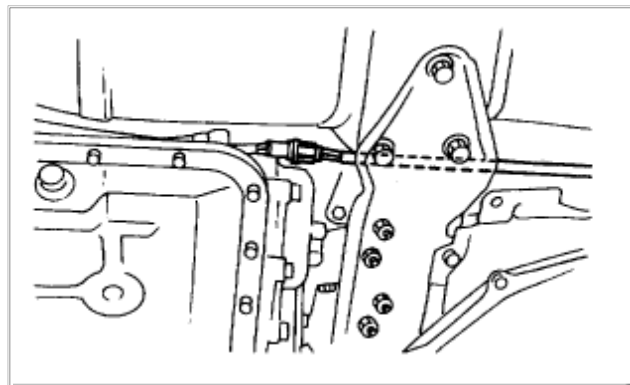
[Zoom](#)[Sized for Print](#)

- 10) Disconnect connector from rear oxygen sensor. (Except California 2200 cc model)

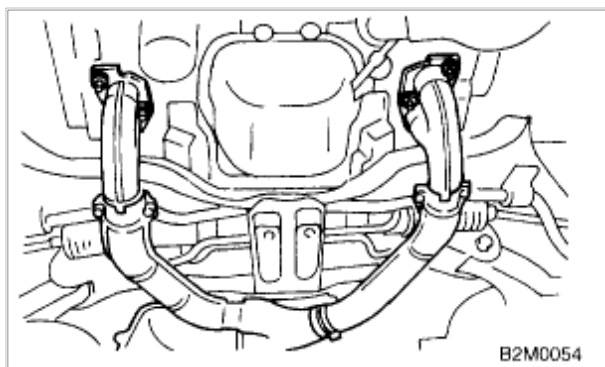
[Zoom](#)[Sized for Print](#)

11) Remove front [exhaust pipe](#).

- a) Separate front [catalytic converter](#) from center [exhaust pipe](#).
- b) Remove front [exhaust pipe](#) from engine.
- c) Remove bolt which installs front [exhaust pipe](#) on bracket.

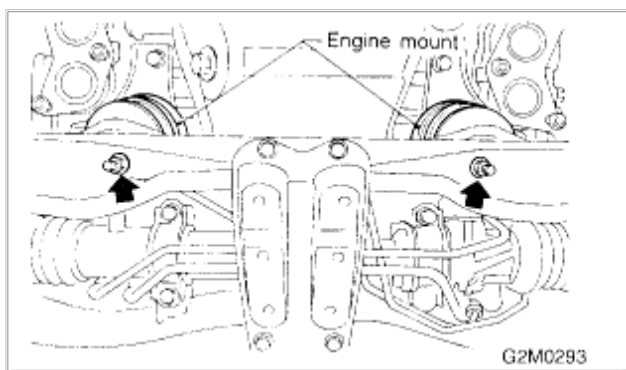
[Zoom](#)[Sized for Print](#)

12) Remove nuts which install front cushion rubber onto front crossmember.

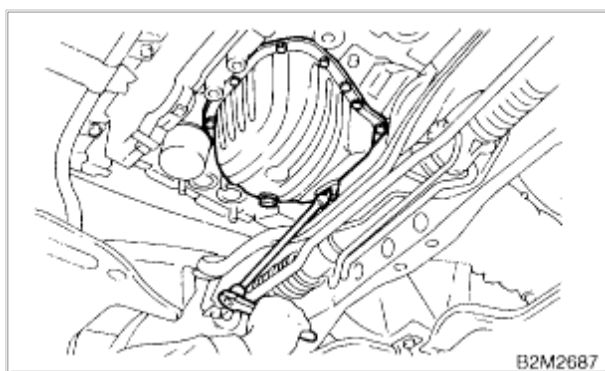
[Zoom](#)[Sized for Print](#)

- 13) Remove bolts which install oil pan on cylinder block while raising up engine.
- 14) Insert oil pan cutter blade between cylinder block-tool pan clearance.

CAUTION: Do not use a screwdriver or similar tool in place of oil pan cutter.

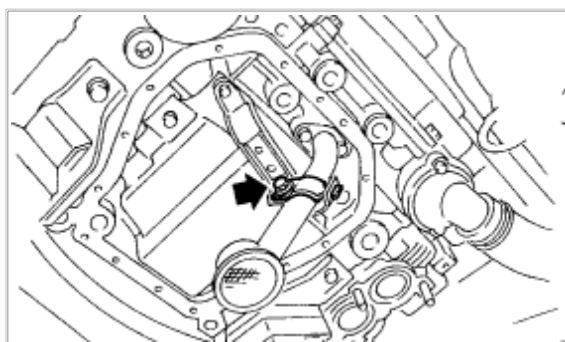
[Zoom](#)[Sized for Print](#)

- 15) Separate oil strainer from oil strainer stay.

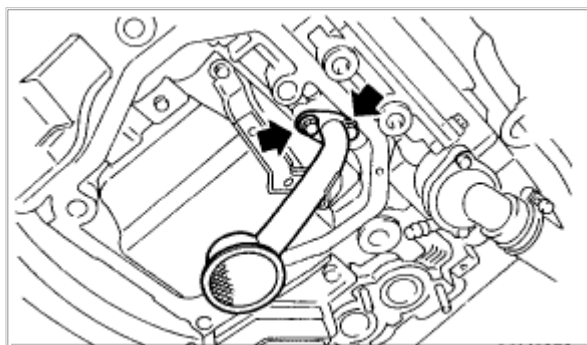

[Zoom](#)[Sized for Print](#)

16) Remove oil strainer.

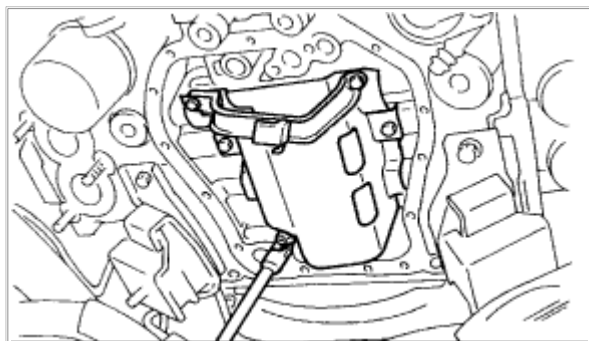
[Zoom](#)[Sized for Print](#)

17) Remove baffle plate and oil strainer stay.

INSTALLATION

CAUTION: Before installing oil pan, clean sealant from oil and engine block.

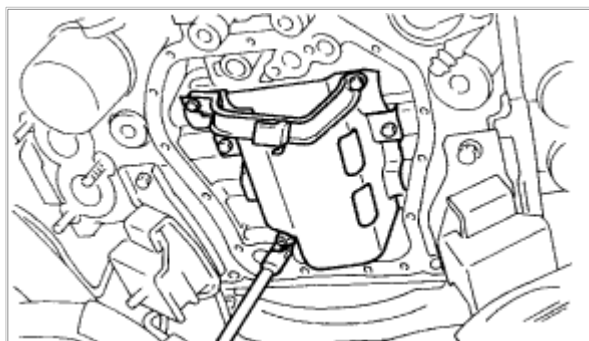
[Zoom](#)[Sized for Print](#)

1) Install baffle plate and oil strainer stay.

Tightening torque: 5 Nm (0.5 kg-m, 3.6 ft. lbs.)

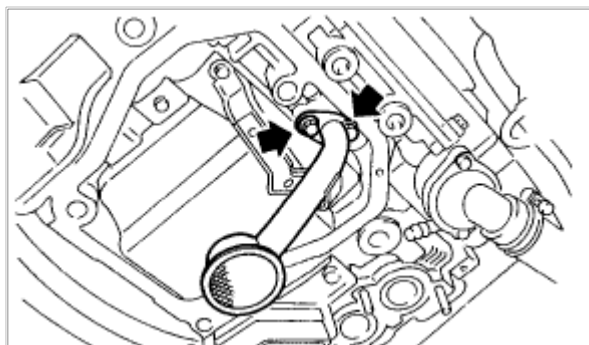
[Zoom](#)[Sized for Print](#)

- 2) Install oil strainer onto baffle plate.

CAUTION: Replace O-ring with a new one.

Tightening torque: 9.8 Nm (1.0 kg-m, 7 ft. lbs.)

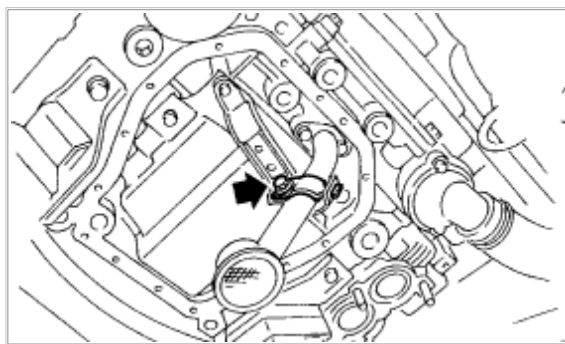
[Zoom](#)[Sized for Print](#)

- 3) Hold oil strainer to oil strainer stay.

Tightening torque: 9.8 Nm (1.0 kg-m, 7 ft. lbs.)

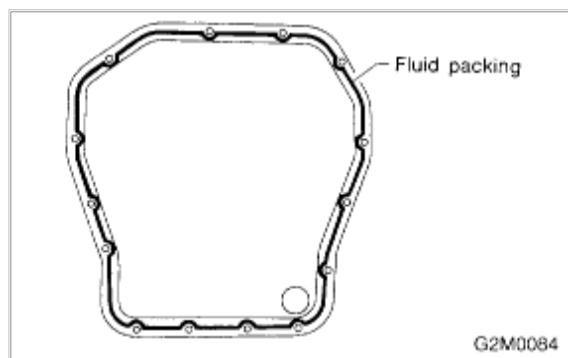

[Zoom](#)[Sized for Print](#)

- 4) Apply fluid packing to mating surfaces and install oil pan.

Fluid packing: THREE BOND 1207C or equivalent

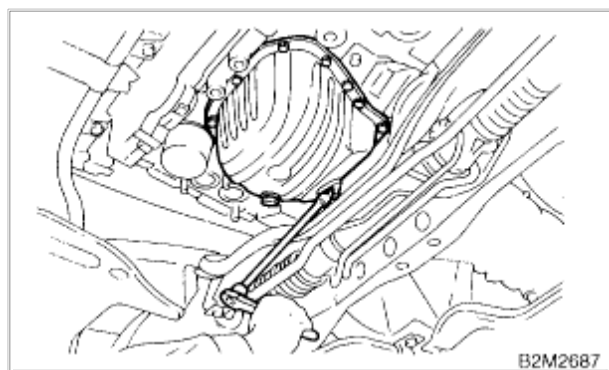
[Zoom](#)[Sized for Print](#)

- 5) Tighten bolts which install oil pan onto engine block.

Tightening torque: 9.8 Nm (1.0 kg-m, 7 ft. lbs.)

- 6) Tighten drain plug.

Tightening torque: 44 ±4.8 Nm (4.5 ±0.5 kg-m, 33 ±3.6 ft. lbs.)

CAUTION: Replace drain plug gasket with new one.

- 7) Lower engine onto front crossmember.

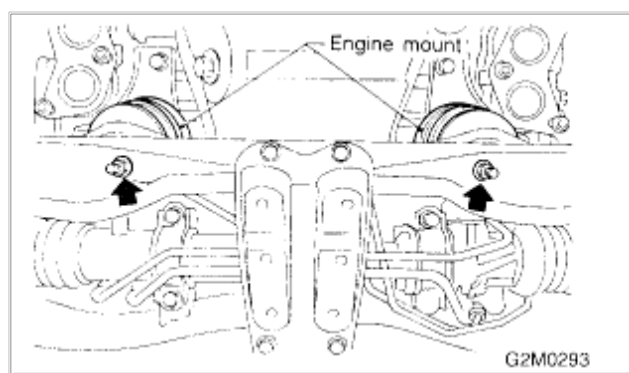
[Zoom](#)[Sized for Print](#)

- 8) Tighten nuts which install front cushion rubber onto front crossmember.

Tightening torque: 69 ±15 Nm (7.0 ±1.5 kg-m, 51 ±11 ft. lbs.)

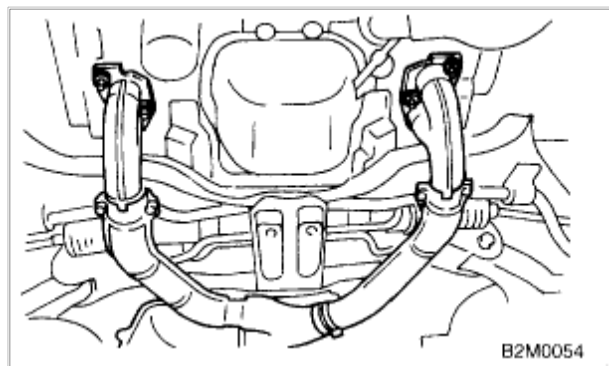
[Zoom](#)[Sized for Print](#)

- 9) Install front [exhaust pipe](#).

CAUTION: Always use the new gaskets.

- 1) Place front [exhaust pipe](#) on bracket.
- 2) Tighten nuts which install front [exhaust pipe](#) on engine.

Tightening torque: 30 ±5 Nm (3.1 ±0.5 kg-m, 22.4 ±3.6 ft. lbs.)

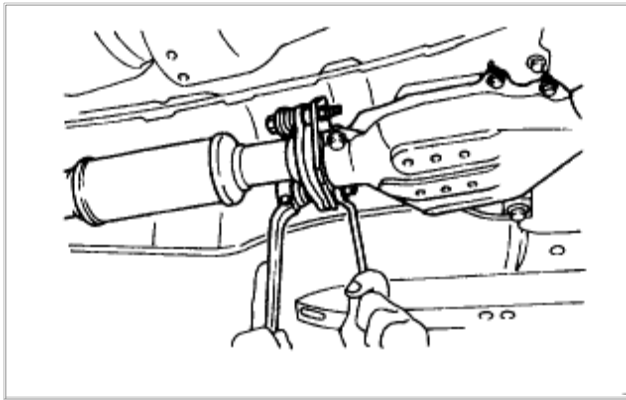
[Zoom](#)[Sized for Print](#)

- 3) Tighten nuts which install front [catalytic converter](#) to center [exhaust pipe](#).

Tightening torque: 35 ±5 Nm (3.6 ±0.5 kg-m, 26.0 ±3.6 ft. lbs.)

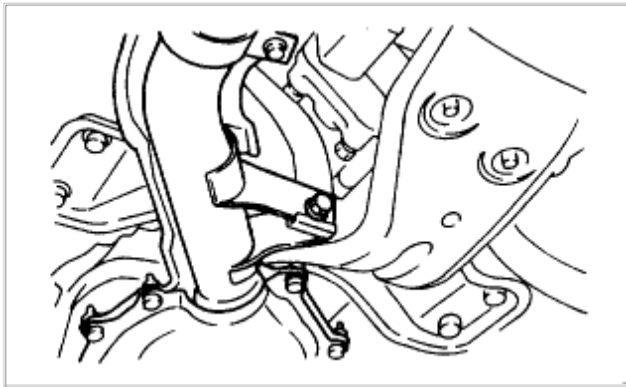
[Zoom](#)[Sized for Print](#)

- 4) Tighten bolt which installs front [exhaust pipe](#) on bracket.

Tightening torque: 24 ±3 Nm (2.4 ±0.3 kg-m, 17.4 ±2.2 ft. lbs.)

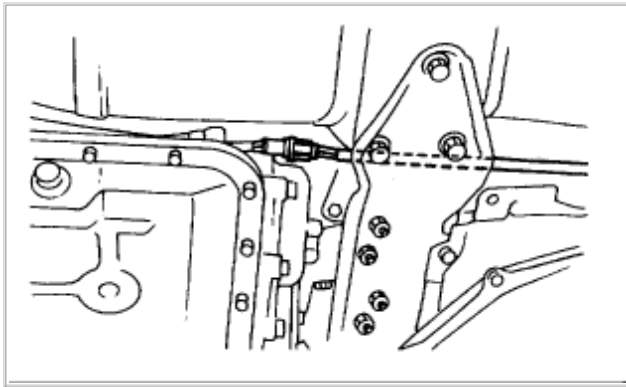
[Zoom](#)[Sized for Print](#)

- 10) Connect connector to rear oxygen sensor. (Except California 2200 cc model)

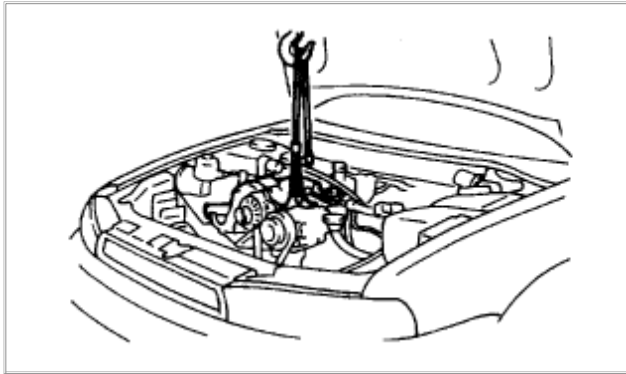
[Zoom](#)[Sized for Print](#)

- 11) Lower the vehicle.

CAUTION: At this time, lower lifting device and release steel cables.

- 12) Remove lifting device and steel cables.

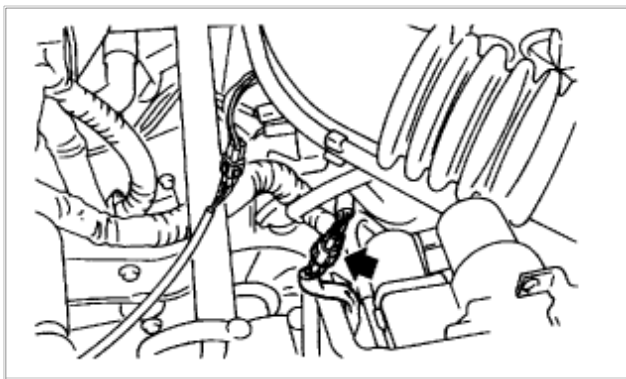

Zoom

Sized for Print

13) Connect connector to front oxygen sensor.

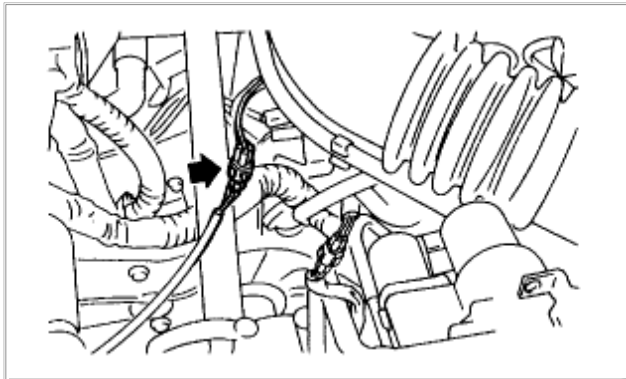

Zoom

Sized for Print

14) Connect connector to rear oxygen sensor. (California 2200 cc model only)

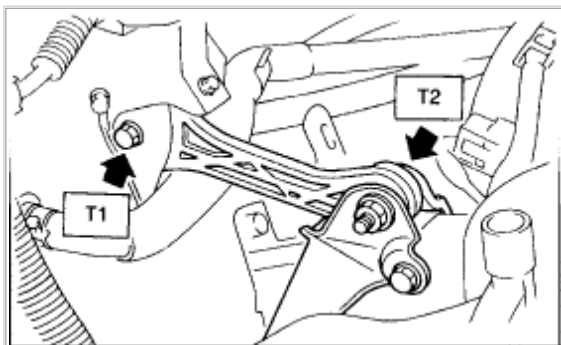

Zoom

Sized for Print

- 15) Install pitching stopper.

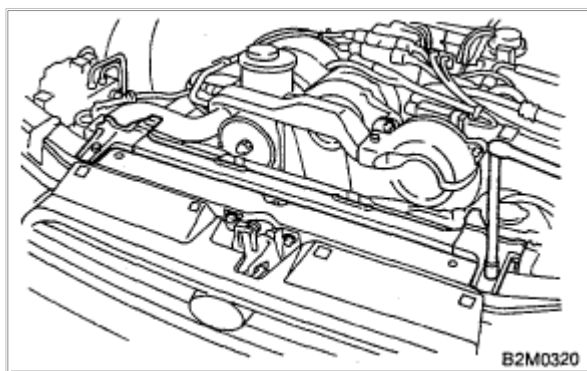
Tightening torque:**T1: 49 ± 5 Nm (5.0 ± 0.5 kg-m, 36.2 ± 3.6 ft. lbs.)****T2: 57 ± 10 Nm (5.8 ± 1.0 kg-m, 42 ± 7 ft. lbs.)**

Zoom

Sized for Print

- 16) Install [radiator](#) upper brackets.

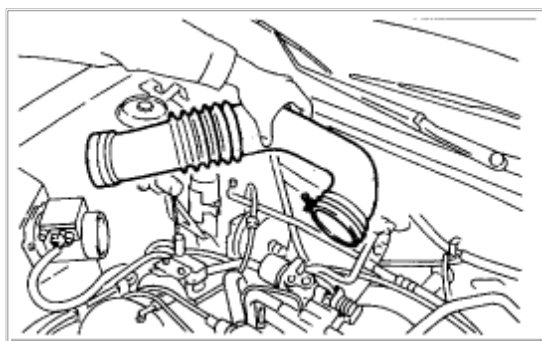
Tightening torque: 12 ± 3 Nm (1.2 ± 0.3 kg-m, 8.7 ± 2.2 ft. lbs.)

Zoom

Sized for Print

- 17) Install air intake duct.

- 18) Fill engine oil through filler pipe up to upper point of level gauge.

Engine oil capacity:

2200 cc:

Upper level: 4.0 L (4.2 US qt., 3.5 Imp qt.)

Lower level: 3.0 L (3.2 US qt., 2.6 Imp qt.)

2500 cc:

Upper level: 4.5 L (4.8 US qt., 4.0 Imp qt.)

Lower level: 3.5 L (3.7 US qt., 3.1 Imp qt.)

© 2008 ALldata LLC. All rights reserved.

[Terms of Use](#)