

[Select Vehicle](#) | [New TSBs](#) | [Technician's Reference](#)

Component Search:

 1992 Ford Truck E 150 Van L6-300 4.9L[Vehicle Level](#) → [Heating and Air Conditioning](#) → [Heater Core](#) → [Service and Repair](#) ←

Service and Repair

[Notes](#)

Heater Assembly

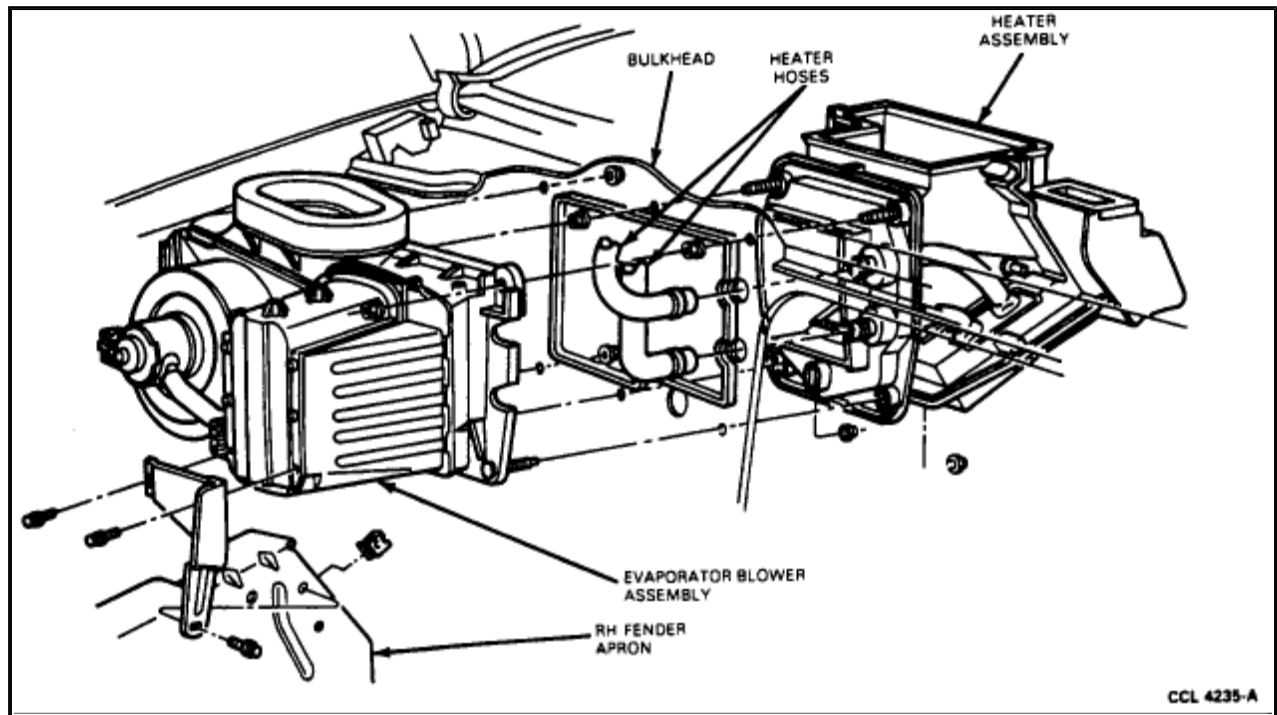

There are four carriage bolts which pass through holes in the instrument panel, located around the edges of a large cutout in the panel. This cutout is an opening between the heater blower housing assembly on the engine compartment side of the instrument panel and the evaporator core when air conditioning is provided as an option. This evaporator housing assembly includes other components which are common to heating and air conditioning-heating systems, on the passenger compartment side of the panel. Nut and washer assemblies draw the two major components together through their gaskets at the instrument panel.

REMOVAL AND INSTALLATION

1. Drain [cooling system](#).
2. Remove the heater water hoses from the heater core in the engine compartment

and plug hoses.

3. Remove modesty panel which runs along the lower edge of the instrument panel (04320).

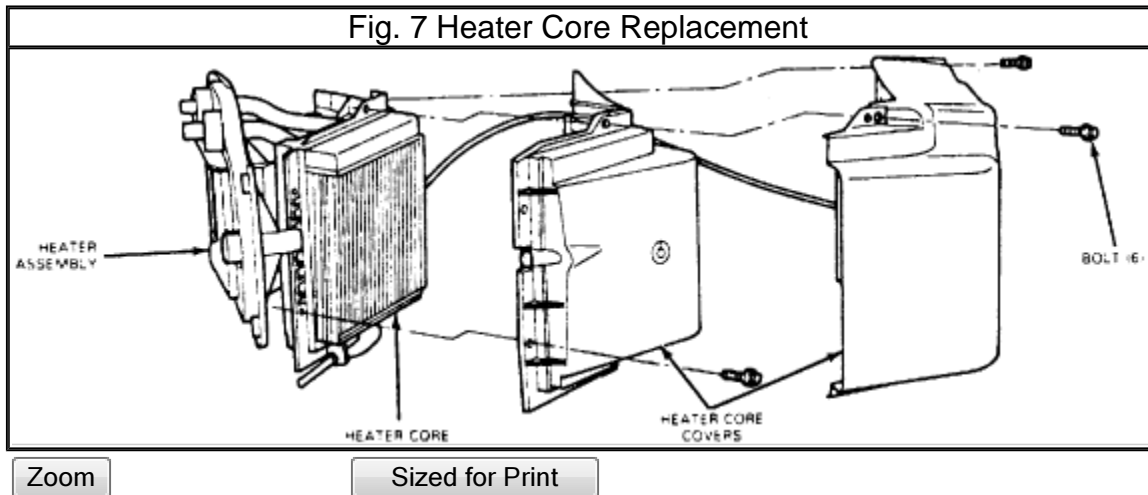

4. Remove the six screws from the heater core cover (18B300) **Fig. 7.** located on both sides of the heater assembly case.
5. Remove heater core cover.
6. Remove heater core and heater core case seal (18658) from the heater assembly.
7. Reverse procedure to install, refill [cooling system](#).

© 2010 ALLDATA LLC. All rights reserved.

[Terms of Use](#)