

## Service and Repair

[Notes](#)

## Cooling Fan - Blade, Clutch and Shroud

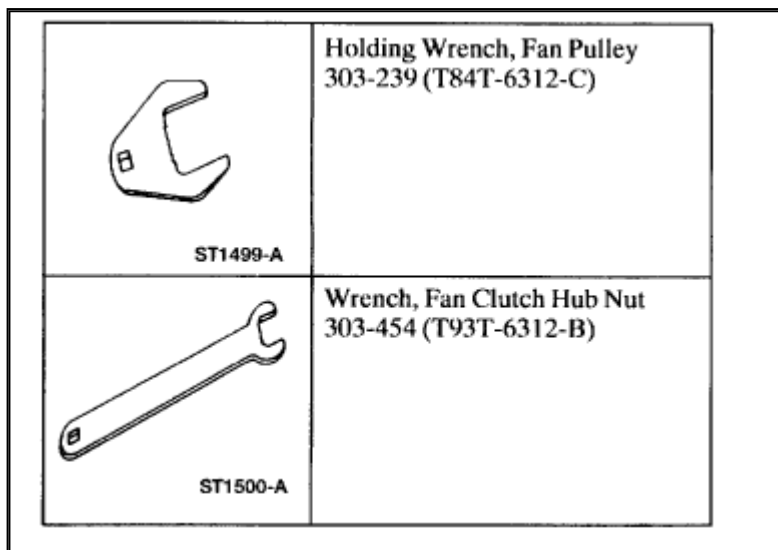

Zoom

Sized for Print

## Special Tool(s)

## Removal and Installation

**WARNING:** Do not run the engine while the protective components are removed. Failure to follow these instructions may result in personal injury.

## All vehicles

1. Remove the air cleaner assembly.
2. Drain the [cooling system](#).

## Supercharged vehicles

3. Remove the supercharger degas bottle.



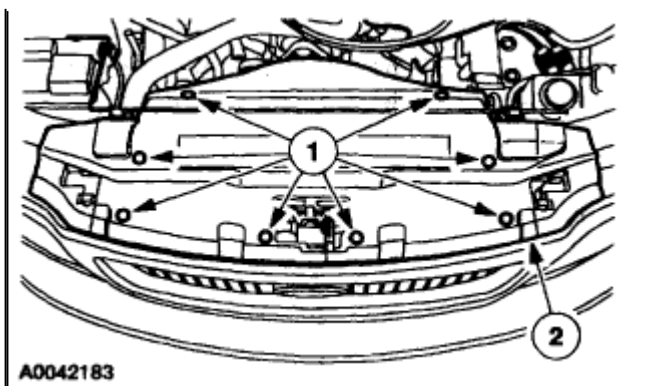

Zoom

Sized for Print

### All vehicles

4. Remove the front air deflector.
- 1 Remove the pin-type retainers.
- 2 Remove the front air deflector.

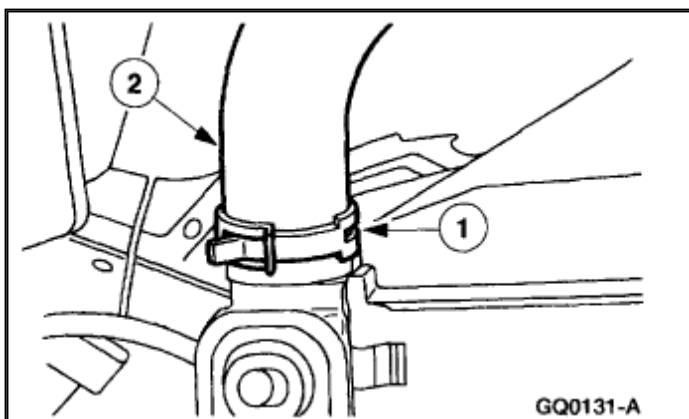

Zoom

Sized for Print

5. Remove the upper hose from the [radiator](#).
- 1 Release the clamp.
- 2 Disconnect the hose.



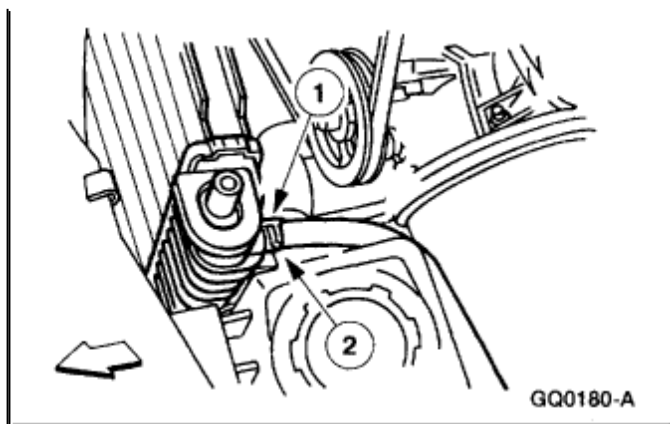

Zoom

Sized for Print

6. Remove the degas bottle hose from the [radiator](#).

- 1 Release the hose clamp and slide it away from the end of the hose.
- 2 Slide the overflow hose off the [radiator](#) fitting.

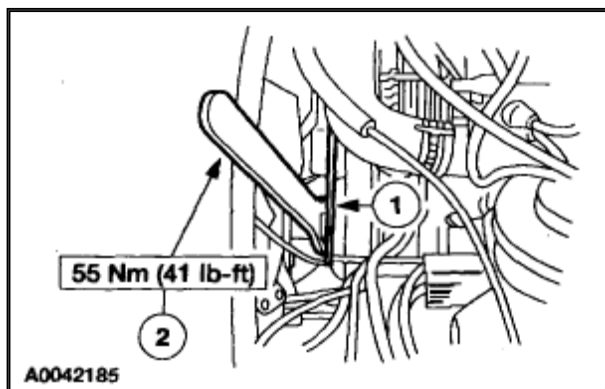

Zoom

Sized for Print

7. Remove the [fan blade](#) assembly and [fan clutch](#).

- 1 Use the fan pulley holding wrench to hold the [water pump](#) pulley steady.
- 2 Use the [fan clutch](#) nut wrench to remove the [fan blade](#) and the fan clutch.



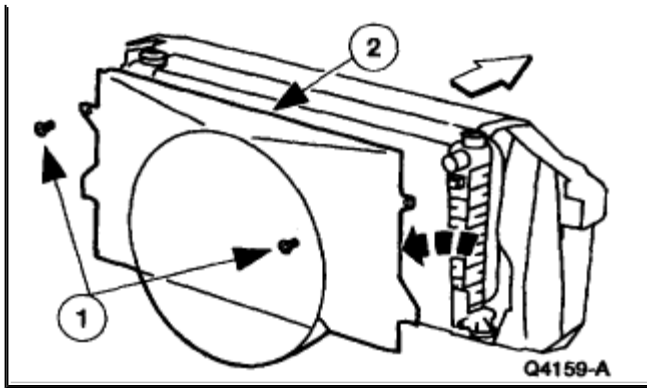

Zoom

Sized for Print

8. Remove the fan shroud.

1 Remove the screws.

2 Lift and remove the fan shroud.

- If equipped, disconnect the harness retaining pin-type retainer from the LH side of fan shroud.

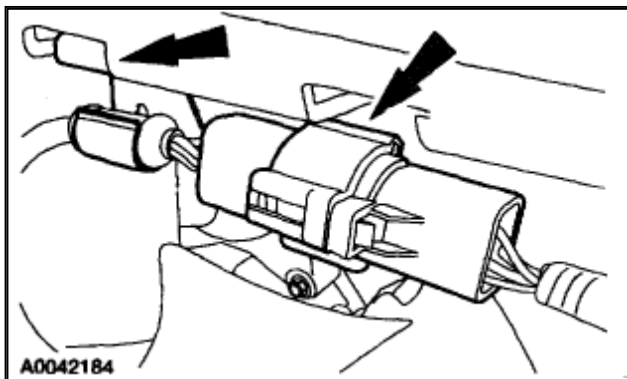

Zoom

Sized for Print

9. **NOTE:** If the lead retaining clip is broken, install a new lead retaining clip. If equipped, disconnect the [fan clutch](#) electrical connector and lead retaining clip.

10. Remove the [fan blade](#) and fan shroud out of the vehicle together.



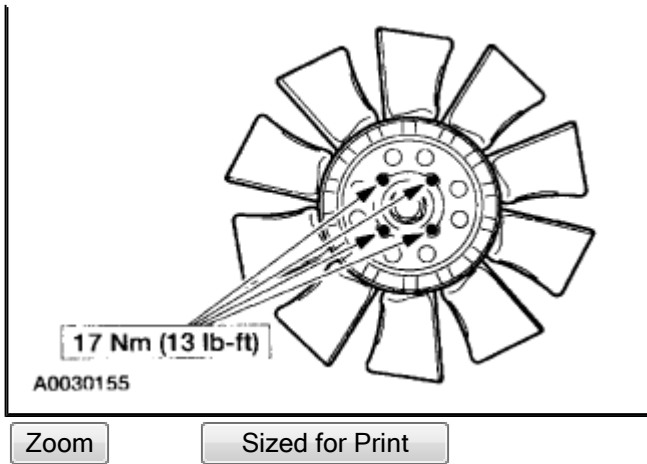

11. Remove the bolts and separate the [fan blade](#) assembly from the [fan clutch](#).
12. **NOTE:** To avoid stripping the threads, use the correct bolts when installing a new [fan clutch](#). Use bolts 575632-S426 for fan clutch F85A-8A616 and bolts N602548-S426 for fan clutch 2L34-8A616 and 2C64-8A616. To install, reverse the removal procedure.