

Brake Pads Vehicles Without: Brembo Brakes

Special Service tools

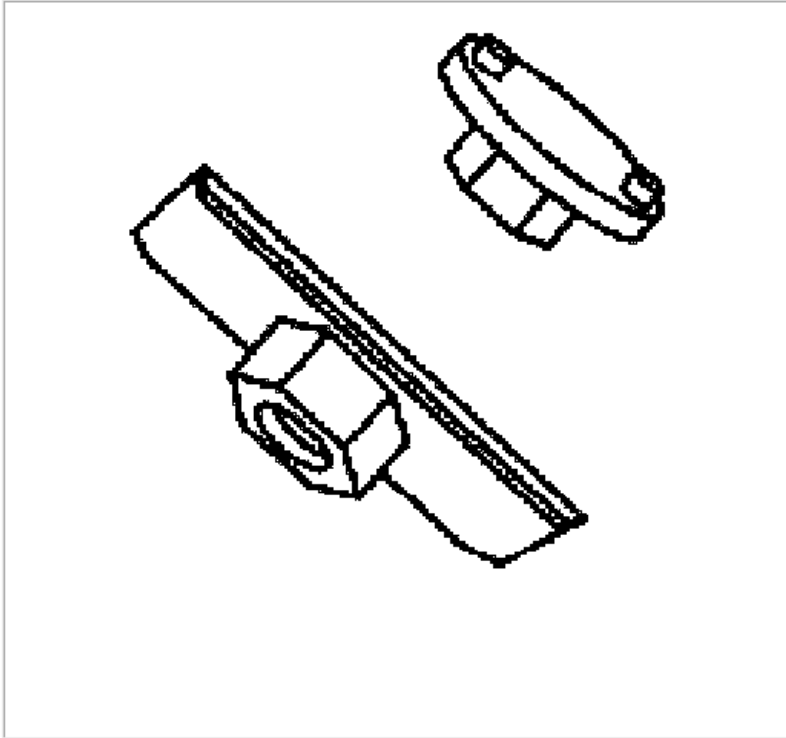

Brake caliper piston retractor tool 206-080

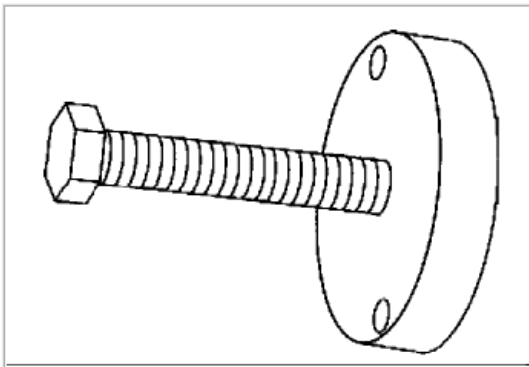

Crankshaft pulley/damper remover 303-588

Removal

1. Carry out the parking brake cable tension release procedure.
2. Remove both rear wheels and tires.



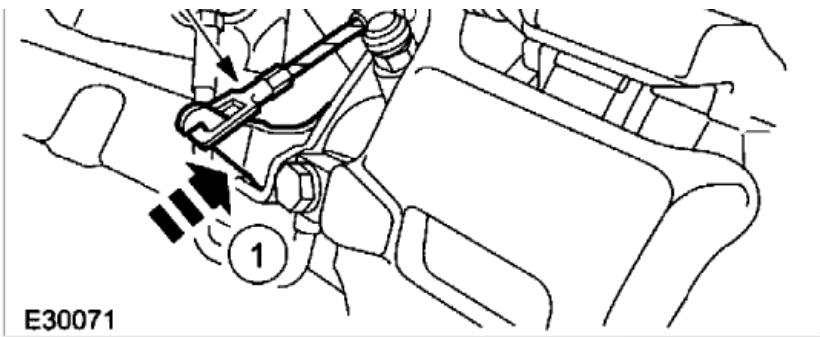

3. Detach the parking brake cable.
1. Reposition the brake caliper lever.
2. Detach the parking brake cable.

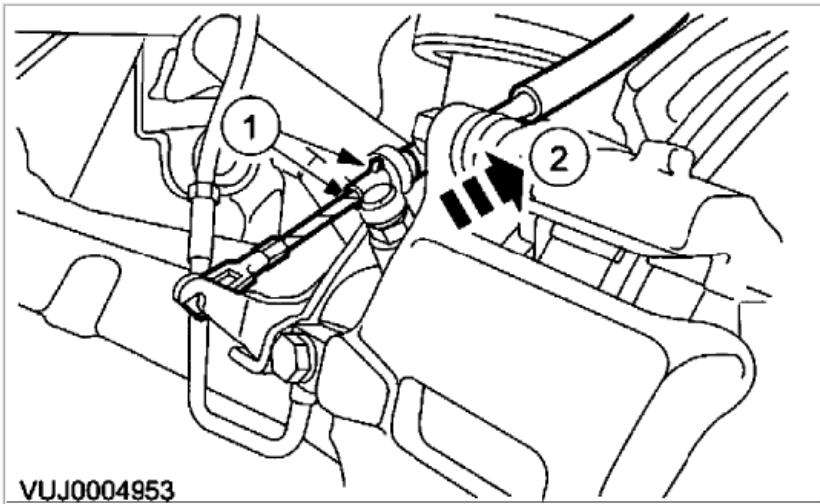

4. Detach the parking brake cable.
1. Release the retaining tangs.
2. Detach the parking brake cable.

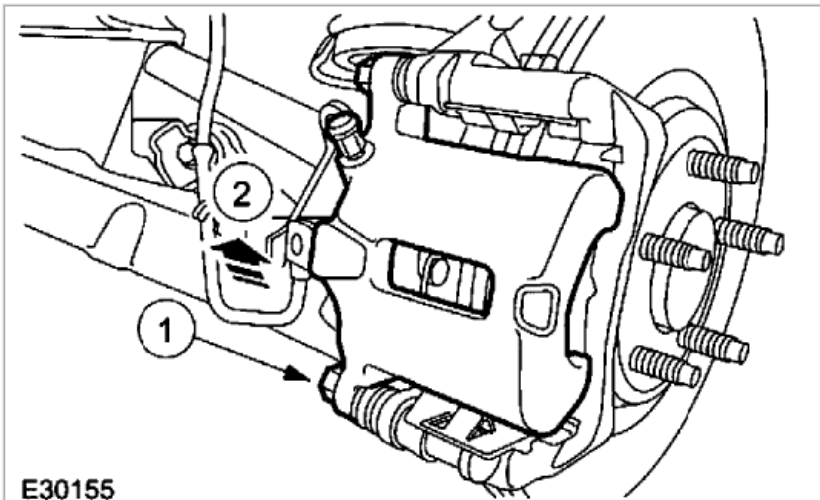

- b. Rotate the brake caliper upwards.
1. Remove and discard the brake caliper lower retaining bolt.
2. Rotate the brake caliper upwards.

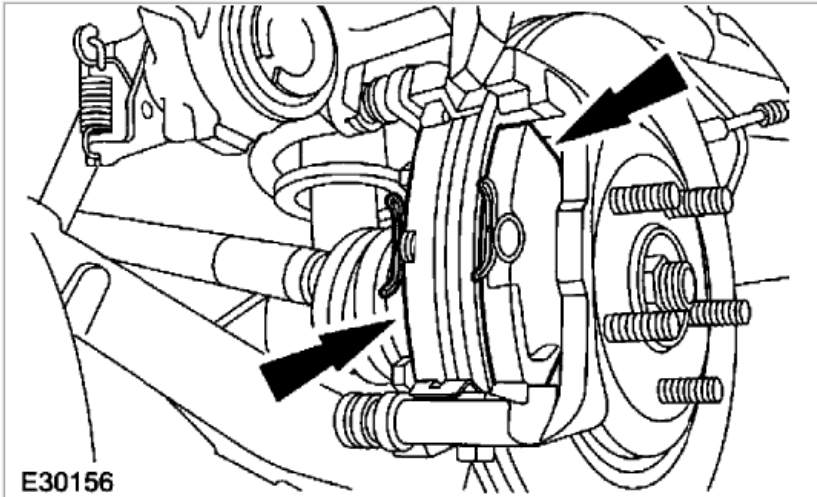

6. Remove the brake pads.
 - Remove the brake pad anti-rattle spring plates.

Installation

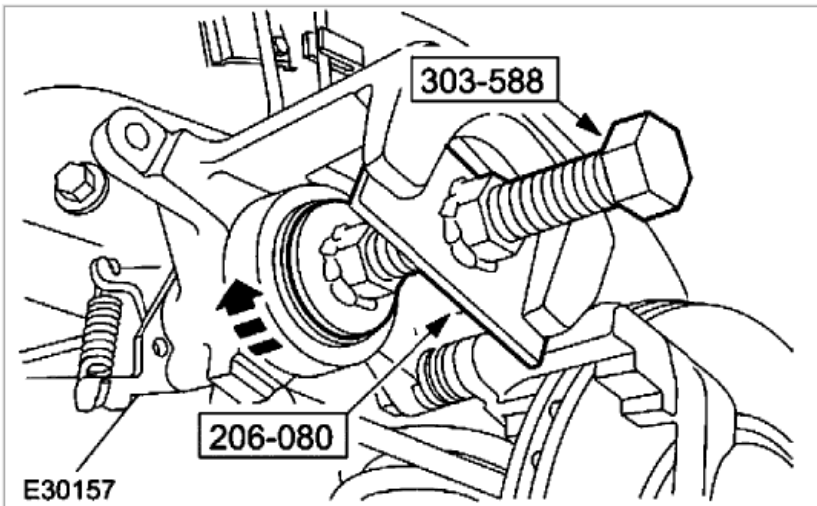

1. **WARNING: DO NOT USE A COMPRESSED AIR TO DISPERSE BRAKE DUST INTO THE ATMOSPHERE.**
 - **CAUTION:** If the pistons are pushed back into the housing, brake fluid will be forced back into the brake fluid reservoir.
 - **CAUTION:** Make sure that the brake disc faces are clean before installation.
 - **CAUTION:** Brake pads must always be replaced in axle sets.

NOTE: Remove the forcing screw from the crankshaft pulley/damper remover and install to the brake caliper piston retractor tool.

Using the special tools, fully retract the brake caliper pistons.



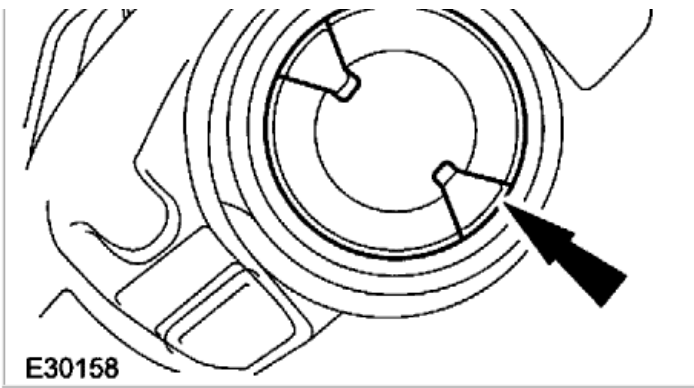

2. Make sure the brake caliper piston location mark is in the correct position so that the locator pin on the brake pad locates correctly into the brake caliper piston.

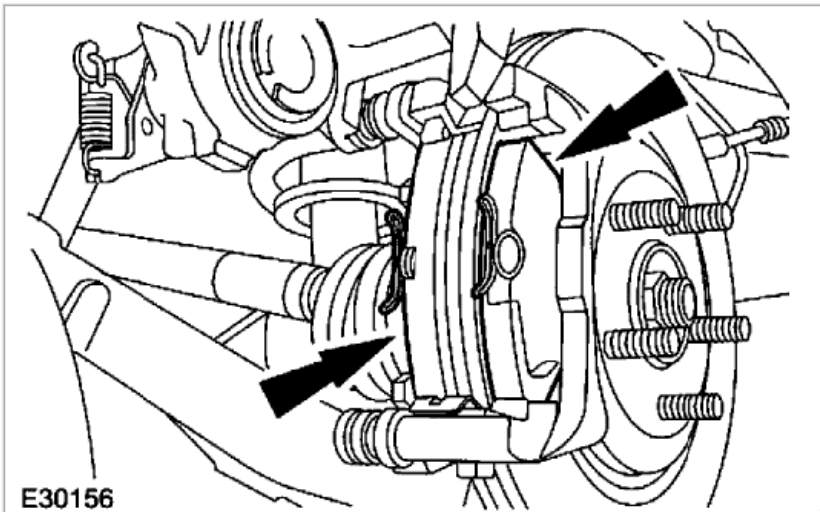

3. **NOTE:** Remove the forcing screw from the brake caliper piston retractor tool and install to the crankshaft pulley/damper remover.

Install new brake pads.

- Install the brake pad anti-rattle spring plates.

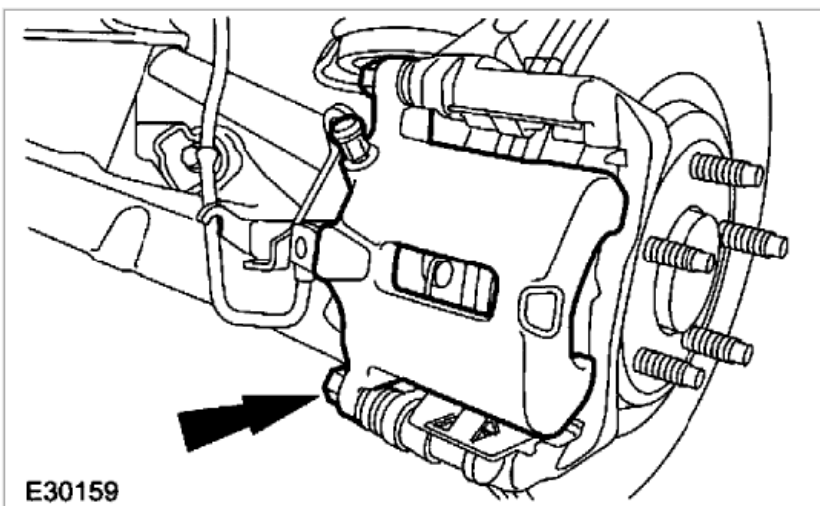

4. Install a new brake caliper lower retaining bolt.

- Tighten to **34 Nm**.

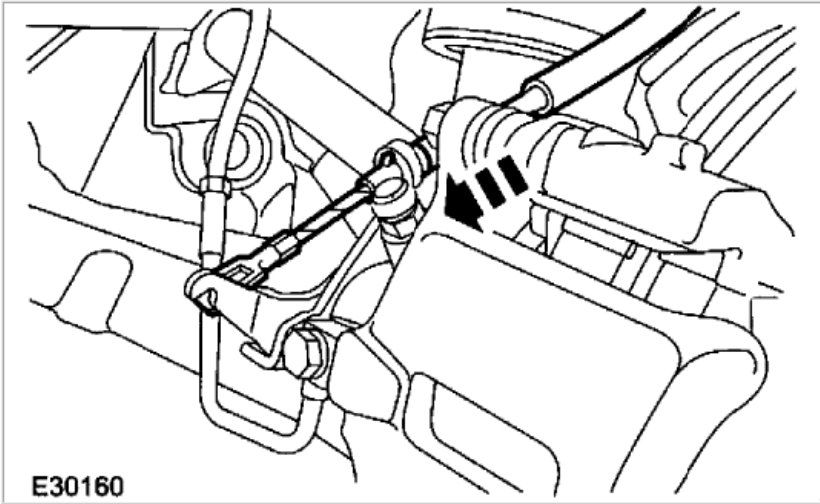

5. Attach the parking brake cable.

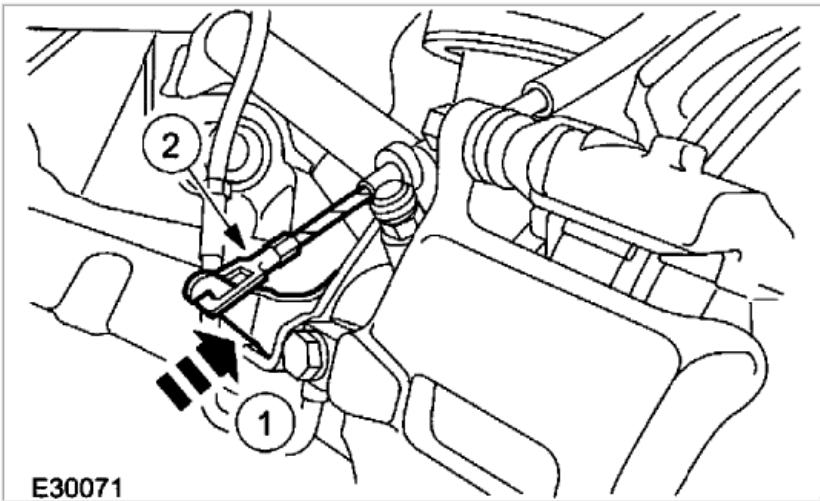

6. Attach the parking brake cable.

1. Reposition the brake caliper lever.
 2. Attach the parking brake cable.
7. Install both rear wheels and tires.