

Halfshaft Assembly — LH (1.8L and 1.9L), RH (1.9L)

**SPECIAL SERVICE TOOL(S)
REQUIRED**

Description	Tool Number
Transaxle Plugs	T88C-7025-AH

NOTE: This procedure covers the removal and installation of the LH and RH front wheel driveshaft and joints. However, in the case of 1.8L engines, a halfshaft (3A329) is placed between the transaxle and the (outboard) front wheel driveshaft and joint (3B436) .

For removal and installation procedures of either the two-piece RH front wheel driveshaft and joint assembly or the RH front wheel driveshaft and joint outboard half only, refer to the appropriate procedures in this section.

Removal

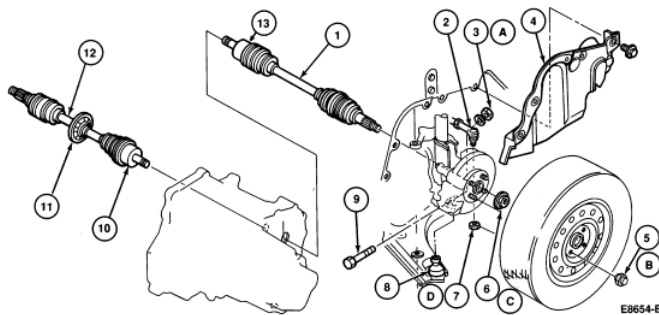

Item	Part Number	Description
1	3B437, LH (1.8L and 1.9L)	Front Wheel Driveshaft and Joint
2	3A130	Tie Rod End
3	—	Ball Joint Bolt Nut
4	16102	Front Fender Splash Shield
5	1012 (4 Req'd)	Lug Nut
6	3B477	Front Axle Wheel Hub Retainer
7	—	Tie Rod End Nut
8	3050	Front Suspension Lower Arm Ball Joint
9	3Z098	Ball Joint Bolt
10	3B414	Front Wheel Driveshaft Joint
11	—	Dynamic Damper (Part of 3B436) (1.9L)
12	3B436, RH (1.9L Only)	Front Wheel Driveshaft and Joint
13	3B414	Front Wheel Driveshaft Joint
A	—	Tighten to 43-59 Nm (32-43 Lb-Ft)
B	—	Tighten to 88-18 Nm (65-87 Lb-Ft)
C	—	Tighten to 235-319 Nm (174-235 Lb-Ft)
D	—	Tighten to 34-46 Nm (25-33 Lb-Ft)

1. Raise and support the vehicle.
2. Remove the lug nuts (1012) and the front wheel and tire assembly.
3. Remove the front fender splash shield bolts and the front fender splash shields (16103) .
4. Use a small cape chisel to carefully raise the staked portion of the front axle wheel hub retainer (3B477) .

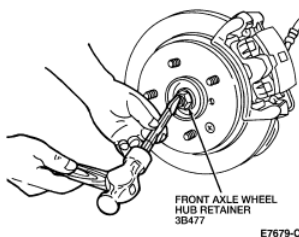

5. Remove the front axle wheel hub retainer and discard it.
6. Remove the cotter pin and the tie rod end nut from the tie rod end (3A130) . Discard the cotter pin.

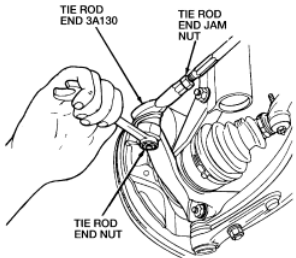

G7361-D

7. Use an appropriate tie rod end remover to separate the tie rod end from the front wheel knuckle (3K186) .

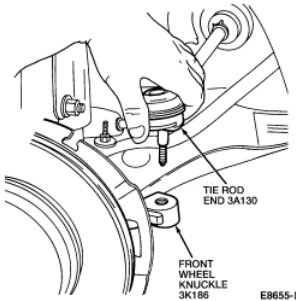

E8655-D

8. Remove the ball joint bolt and the ball joint nut.

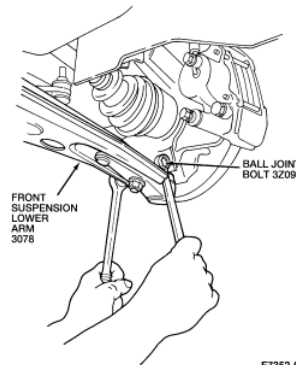

F7352-C

9. Carefully pry down on the front suspension lower arm (3078) to separate the front suspension lower arm ball joint (3050) from the front wheel knuckle .

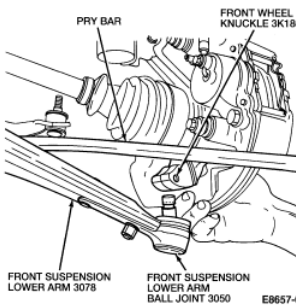

E8657-C

10. Pull outward on the front wheel knuckle (3K185) . Carefully pull the front wheel driveshaft and joint from the front wheel knuckle and position it aside.

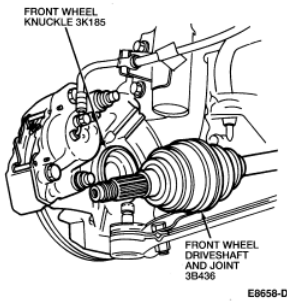

11. **NOTE:** Removal of the LH front wheel driveshaft and joint (3B437) requires removal of the rear engine support (6A023) to allow access with a pry bar. If the LH front wheel driveshaft and joint is being removed, continue with step 11. If the RH front wheel driveshaft and joint is being removed, continue with step 15.

Support the transaxle with a transaxle jack or equivalent.

12. Remove the four transaxle mount-to-rear engine support nuts.

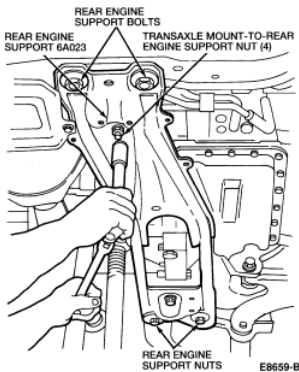

13. Remove the two rear engine support nuts at the rear of the rear engine support .
14. While supporting the rear of the rear engine support remove the two rear engine support bolts. Remove the rear engine support .

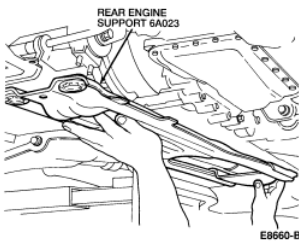

15. Position a drain pan under the transaxle.
16. Insert a pry bar between the front wheel driveshaft and joint and the transaxle case.
17. **CAUTION:** Extreme care must be taken to ensure that the pry bar does not damage the transaxle case, the transaxle oil seal, the front wheel driveshaft and joint , or the front wheel driveshaft joint boot (3A331) .

Gently pry outward to release the front wheel driveshaft and joint from the differential side gears (4236) .

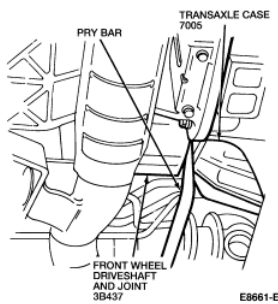

18. Remove the front wheel driveshaft and joint .

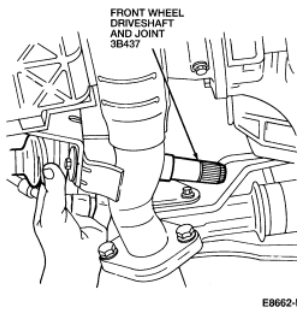

19. **CAUTION:** When the LH and RH front wheel driveshaft and joint assemblies are removed, Transaxle Plugs T88C-7025-AH must be inserted to prevent the differential side gears from becoming mispositioned. If the gears become misaligned, the differential will have to be removed from the transaxle to align the gears.

If both front wheel driveshaft and joints were removed, install Transaxle Plugs T88C-7025-AH in the differential side gears .

20. Remove and discard the driveshaft bearing retainer circlip (3Z498) .

Installation

1. **NOTE:** The original driveshaft bearing retainer circlip must not be reused.

Position a new driveshaft bearing retainer circlip on the inner front wheel driveshaft joint spline so that the driveshaft bearing retainer circlip gap is at the top. Lubricate the splines lightly with Motorcraft Premium Long Life Grease XG-1-C or -K or equivalent meeting Ford specification ESA-M1C75-B.

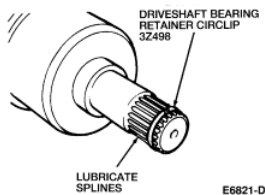

2. If necessary, remove the transaxle plugs from the differential side gears .
3. **NOTE:** When seated properly, the driveshaft bearing retainer circlip can be felt as it snaps into the differential side gear groove.

Position the front wheel driveshaft and joint so the front wheel driveshaft and joint splines are aligned with the differential side gear splines. Push the front wheel driveshaft and joint into the differential side gear .

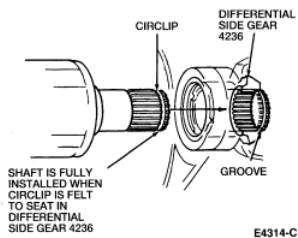

4. Pull outward on the front wheel knuckle and insert the front wheel driveshaft and joint splines into the front wheel knuckle .
5. Pry downward on the front suspension lower arm and position the front suspension lower arm ball joint in the front wheel knuckle .
6. For LH front wheel driveshaft and joint installation, position the rear engine support in place.
7. Install the two rear engine support bolts and the two rear engine support nuts. Tighten the rear engine support nuts to 37-52 Nm (27-38 lb-ft) and the rear engine support bolts to 64-89 Nm (47-66 lb-ft).
8. Install the four transaxle mount-to-rear engine support nuts. Tighten the transaxle mount-to-rear engine support nuts to 37-52 Nm (27-38 lb-ft).
9. Remove the transaxle jack.
10. Install the ball joint bolt and ball joint bolt nut and tighten the ball joint bolt nut to 43-59 Nm (32-43 lb-ft).
11. Install the tie rod end in the front wheel knuckle .
12. Install the tie rod end nut and tighten it to 34-46 Nm (25-33 lb-ft). Install a new cotter pin.
13. **NOTE:** A new front axle wheel hub retainer must be used.

Install a new front axle wheel hub retainer and tighten it to 235-319 Nm (174-235 lb-ft).

14. **CAUTION:** If the front axle wheel hub retainer splits or cracks after staking, replace it with a new hub retainer nut.

NOTE: The staking tool can be fabricated from an existing hardened chisel. The correct radius on the chisel tip will prevent improper staking. Do not attempt to stake with a sharp edged tool.

Stake the front axle wheel hub retainer using a cold chisel with the cutting edge rounded as shown.

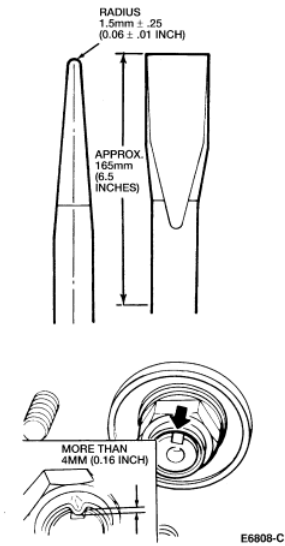

15. Install the front fender splash shields and tighten the front fender splash shield bolts to 8-11 Nm (72-96 lb-in).
 16. Install the front wheel and tire assemblies. Tighten the lug nuts to 88-118 Nm (65-87 lb-ft).
 17. Lower the vehicle.
 18. Check and refill the transaxle with the specified type and amount of fluid. Refer to [Section 07-01](#), [Section 07-03A](#) or [Section 07-03B](#).
-