

2000 Saturn SL2 L4-1.9L DOHC VIN 7

[Vehicle Level](#) → [Powertrain Management](#) → [Ignition System](#) → [Ignition Switch Lock Cylinder](#) → [Technical Service Bulletins](#) → [All Technical Service Bulletins](#) → [Ignition Lock Cylinder - Key Binds/Won't Turn](#) → [Service Procedure](#) → [S - Series](#) ←

S - Series[Notes](#)

IMPORTANT: The important statement at the beginning of the "Ignition Lock Cylinder removal procedure on page 188 in the 2000/2001 Saturn S-Series Body/Electrical Volume II Service Manual is incorrect. Please cross out the important on that page and write in the following important statement.

IMPORTANT: When replacing the ignition lock cylinder only, the passlock relearn procedure is not required.

1. Disconnect negative battery cable.
2. Remove lock cylinder bezel from steering column shroud by carefully prying with a thin bladed screwdriver.

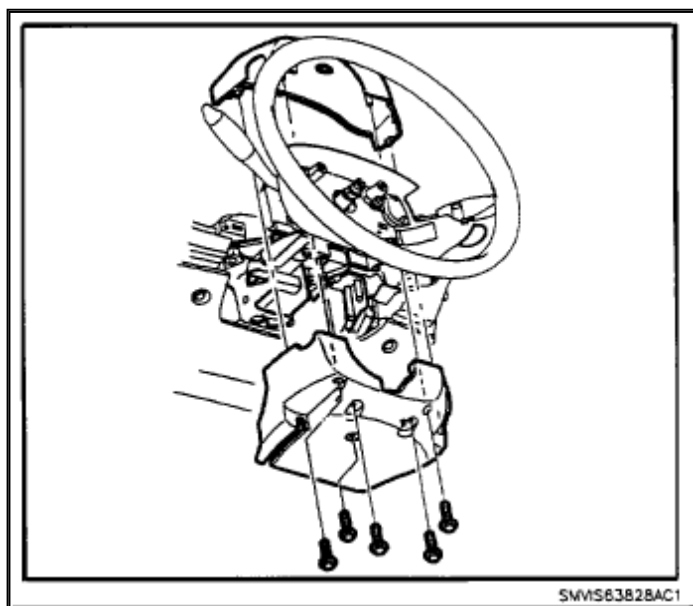

Zoom

Sized for Print

3. Remove shroud fasteners and remove steering column upper and lower shroud panels.
4. Insert key into ignition lock cylinder and rotate to RUN position.

- ^ If ignition lock cylinder can be rotated to RUN position, continue to step 30.
- ^ If ignition lock cylinder cannot be rotated to RUN position, continue with next step.

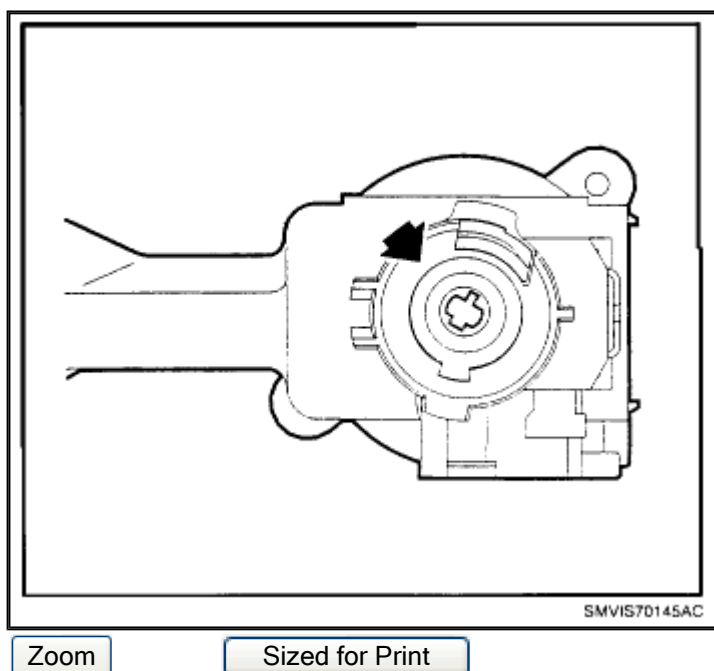

5. Using a light hammer and brass drift, tap lightly on the top side of the ignition housing assembly at the location indicated in the illustration, while trying to turn the ignition key.

- ^ If the ignition key turns, proceed to step 30.
- ^ If the ignition key does not turn replace the ignition module/passlock sensor by continuing with next step.

IMPORTANT: If ignition module/passlock sensor is replaced Passlock relearn procedure must be performed.

6. Disable SIR system. Refer to "Disabling Frontal Inflators" procedure in the 2000/2001 S-Series Body Electrical Volume II Service Manual.

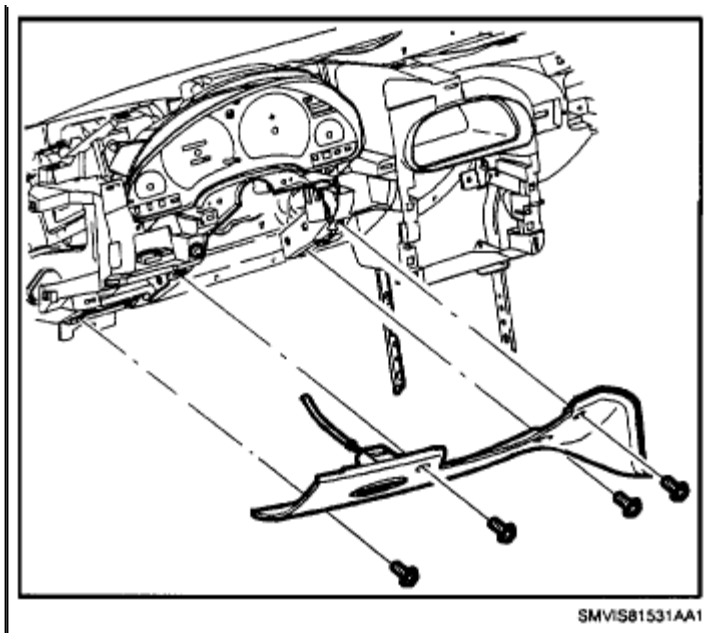

[Zoom](#)[Sized for Print](#)

7. Remove SIR Coil assembly. Refer to "Roll Connector Assembly" removal procedure in the 2000/2001 S-Series Restraints Service Manual.
8. Pull steering column filler panel assembly forward and set aside.

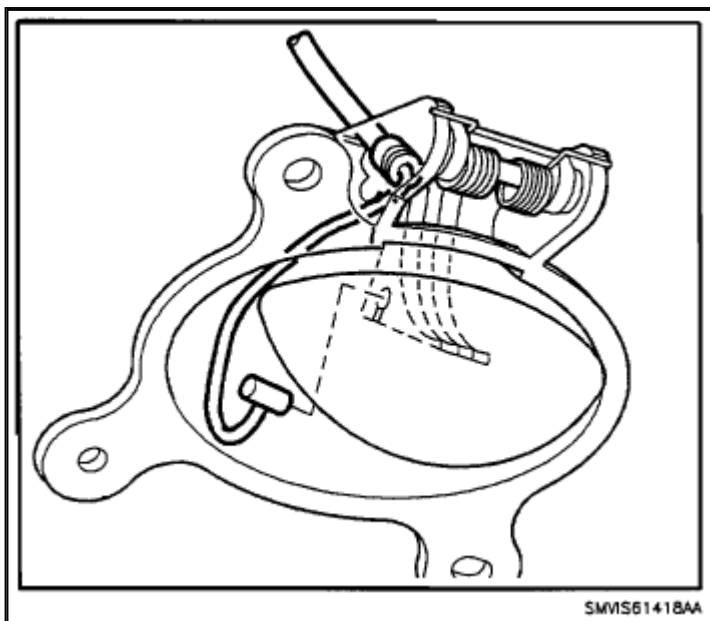
[Zoom](#)[Sized for Print](#)

9. Disconnect cable from filler panel. Pull hood release handle forward. Feed cable under hood release handle and slide pin out. Remove steering column filler panel.
10. Remove connector position assurance (CPA) retainer and disconnect

connectors from lever control switch.

11. With SIR system disabled, remove lever control switch.
12. Disconnect [ignition switch](#) electrical connector at right steering column upper support bracket.
13. On vehicles with automatic transaxles, disconnect park lock cable from ignition module.
14. Disconnect passlock sensor connector from ignition module.

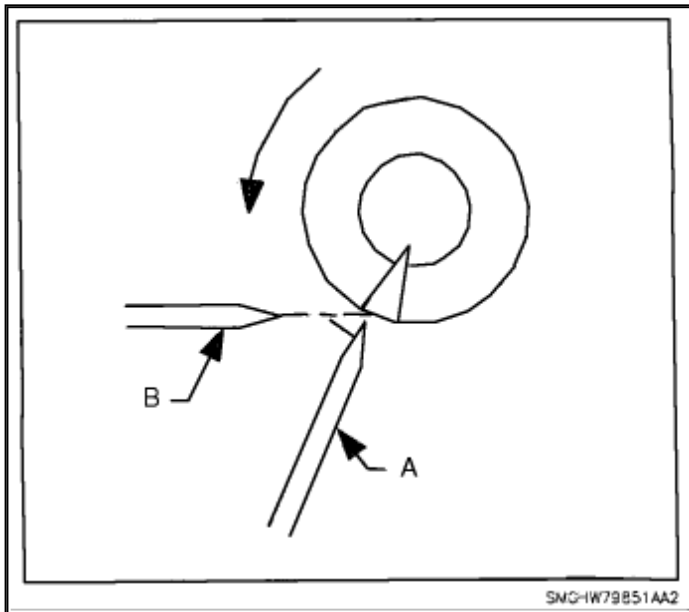

Zoom

Sized for Print

15. Remove ignition module/passlock sensor shear bolts.

15.1 Use a light hammer and a chisel to bite into shear bolt head at a position offset from its center.

15.2 Tap the chisel to rotate the bolt and loosen it.

15.3 Repeat until bolt is loose enough to remove.

16. Remove ignition module/passlock sensor from the steering column.

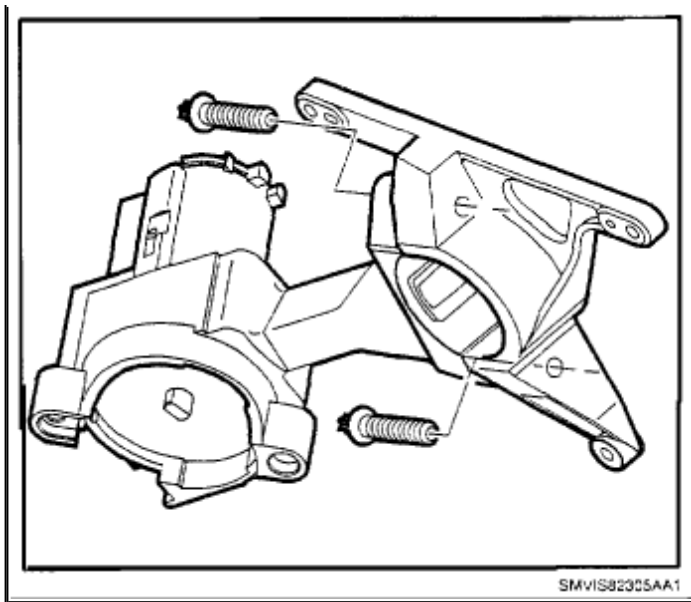

[Zoom](#)[Sized for Print](#)

17. Use new shear bolts to install ignition module/passlock sensor on steering column. Torque shear bolts until heads break off.
18. Install harness clamps on steering column.
19. Connect passlock sensor connector to ignition module.
20. On vehicles with automatic transaxles, connect park lock cable to ignition module.
21. Reconnect passlock sensor connector to ignition module.

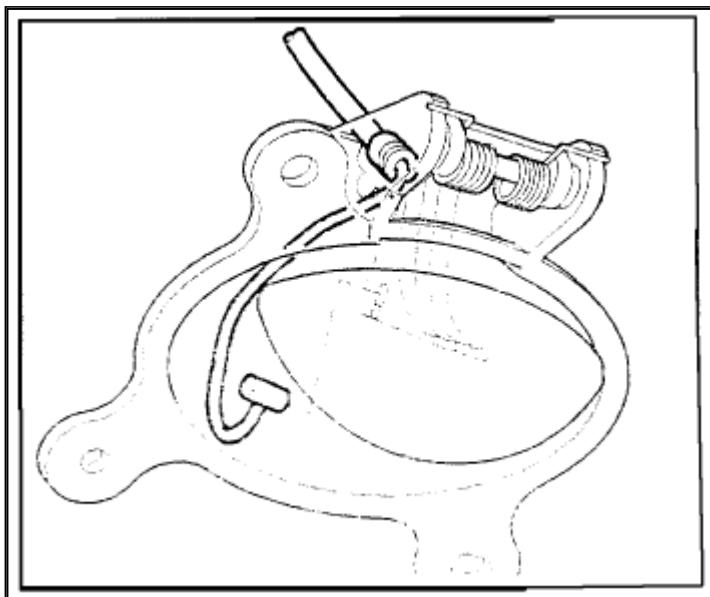
[Zoom](#)[Sized for Print](#)

22. Install lever control switch by fitting into bottom locating holes on ignition

module.

23. Connect connectors to lever control switch. Install connector position assurance (CPA) retainers.
24. Connect [ignition switch](#) electrical connector at right steering column support bracket bolt.
25. Pull hood release handle forward. Feed cable under hood release handle and slide pin in. Connect cable to filler panel.

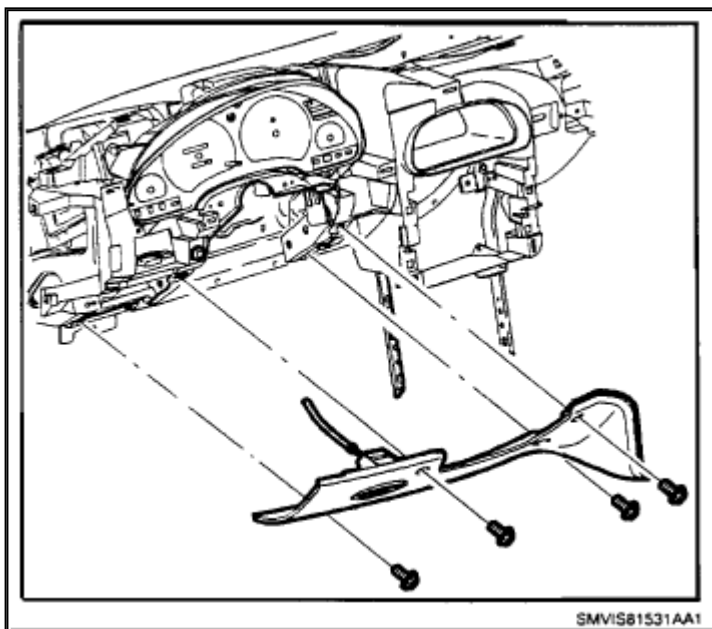

Zoom

Sized for Print

26. Install steering column filler panel and data link connector.
27. Install and torque screws.

Torque:

Steering Column Filler Panel Fasteners: 2.2 Nm (19 in-lbs)

28. Install SIR Coil assembly. Refer to "Roll Connector Assembly" installation procedure in the 2000/2001 S-Series Restraints Service Manual.
29. Enable SIR system. Refer to "Enabling Frontal Inflators" procedure in the 2000/2001 S-Series Body Electrical Volume II Service Manual.
30. Rotate the ignition cylinder back to the ACC position.

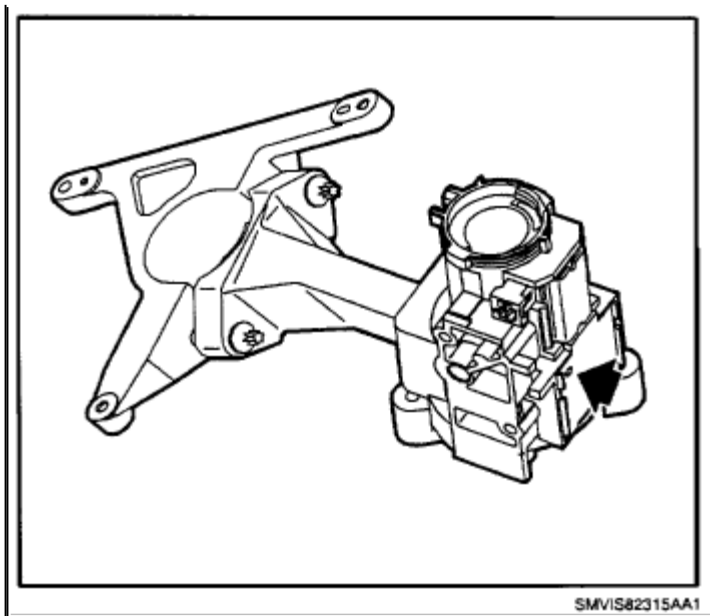

[Zoom](#)[Sized for Print](#)

31. If ignition module/passlock sensor did not require replacement, depress the locking button on the top of ignition module assembly with a thin pick-type tool. Slide lock cylinder assembly from ignition module.
32. Discard old lock cylinder assembly. New lock cylinder and components must be used. Refer to PARTS REQUIREMENTS section in this bulletin for specific parts information.

IMPORTANT: New lock cylinder must be coded. Follow steps 32 through 37 for coding procedure.

IMPORTANT: Ignition lock cylinder reads key cut positions 2 through 10.

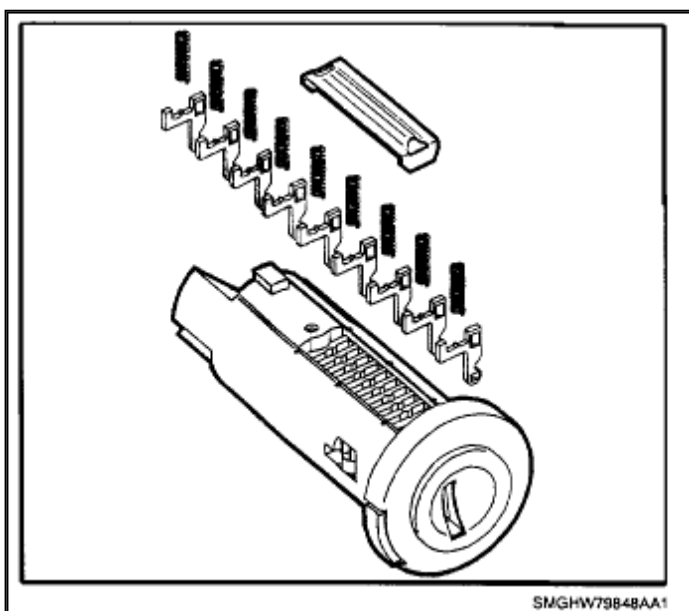

[Zoom](#)[Sized for Print](#)

33. Replace ignition cylinder, ignition cylinder tumblers. and tumbler springs.

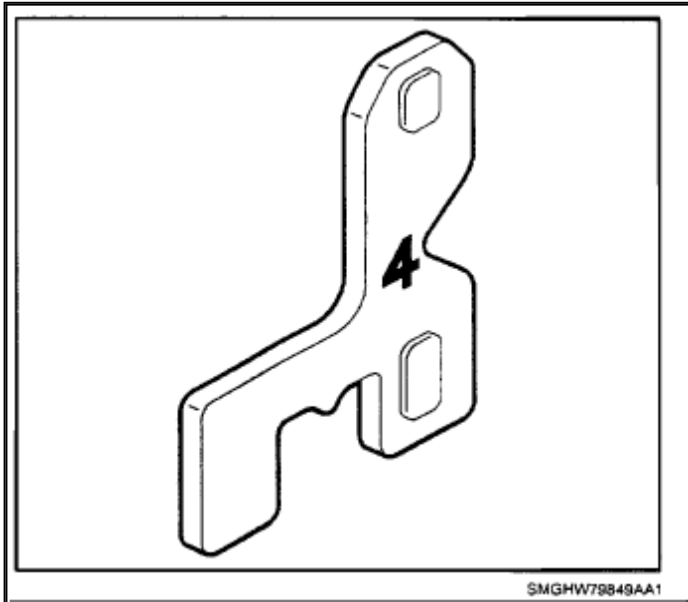
[Zoom](#)[Sized for Print](#)

34. Select the correct tumblers for the desired code by the number stamped on the tumbler.

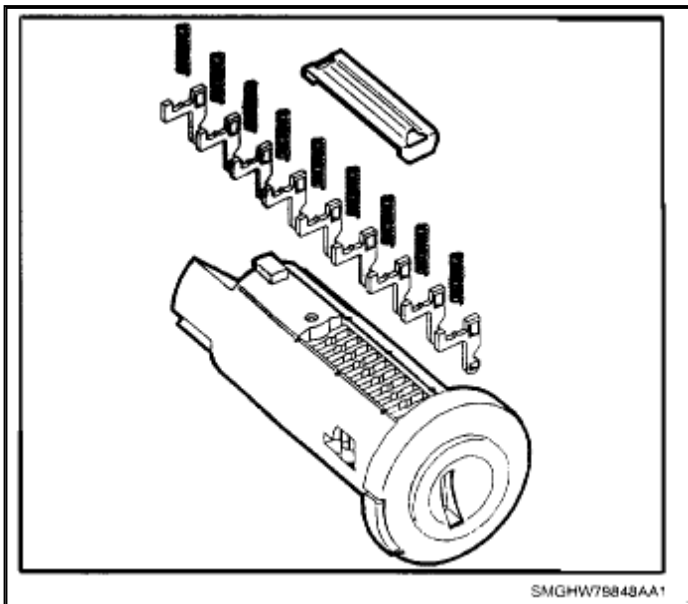
[Zoom](#)[Sized for Print](#)

IMPORTANT: Make sure the ignition cylinder housing side bar is in the correct orientation before attempting to insert tumblers.

35. Install tumblers and tumbler springs.
36. Place a new tumbler retainer plate into position and stake into ignition lock cylinder using Lock Cylinder Holding Fixture and Staking Tool J43877.
 - 36.1 Clamp staking tool holding fixture into a vise.
 - 36.2 Place lock cylinder into staking tool holding fixture.
 - 36.3 Tighten retaining screw.

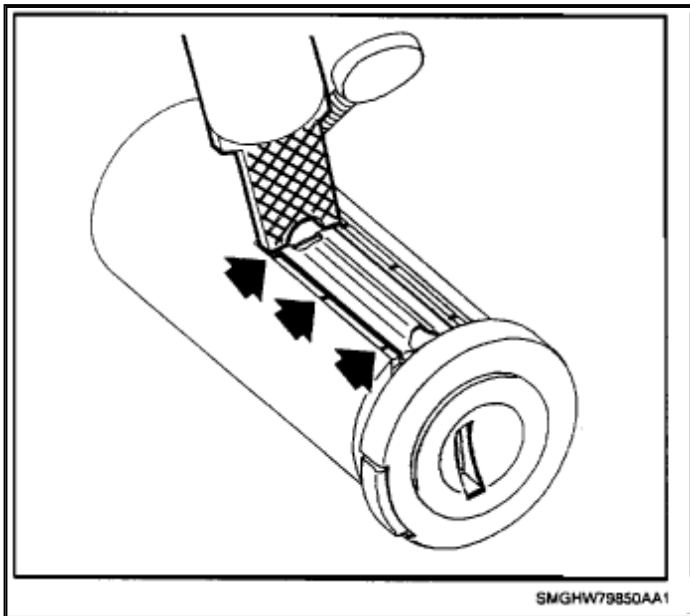
[Zoom](#)[Sized for Print](#)

- 36.4 Stake retainer plate with punch at locations shown in illustration.
37. To check coding of cylinder, insert key. If coding is correct, side-bar will be flush with cylinder with key inserted.
38. For assembly, oil lock set with a light oil or graphite lubricant.

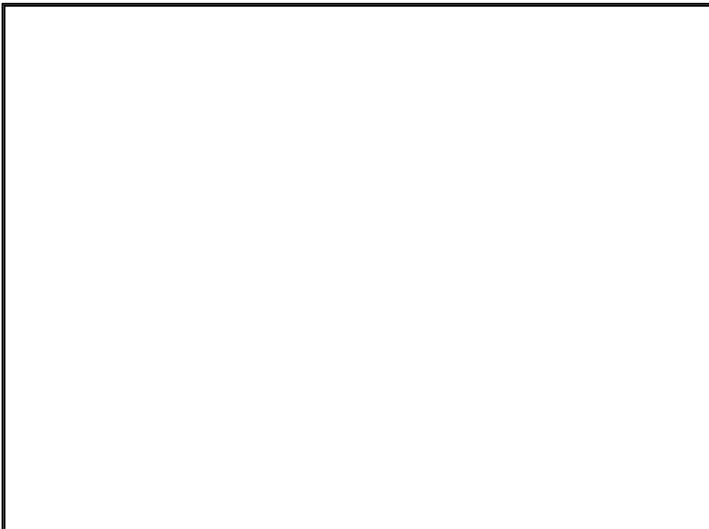

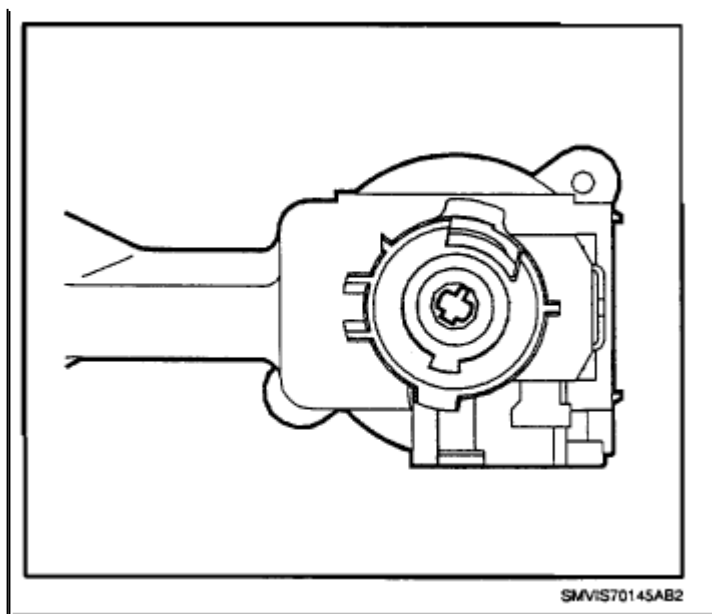
[Zoom](#)[Sized for Print](#)

IMPORTANT: Actuator blade within ignition module housing must be in the ACC position to install lock cylinder assembly. If rotated, replace it to the ACC position using needle nose pliers.

39. Insert ignition key into ignition lock cylinder and install into ignition module.

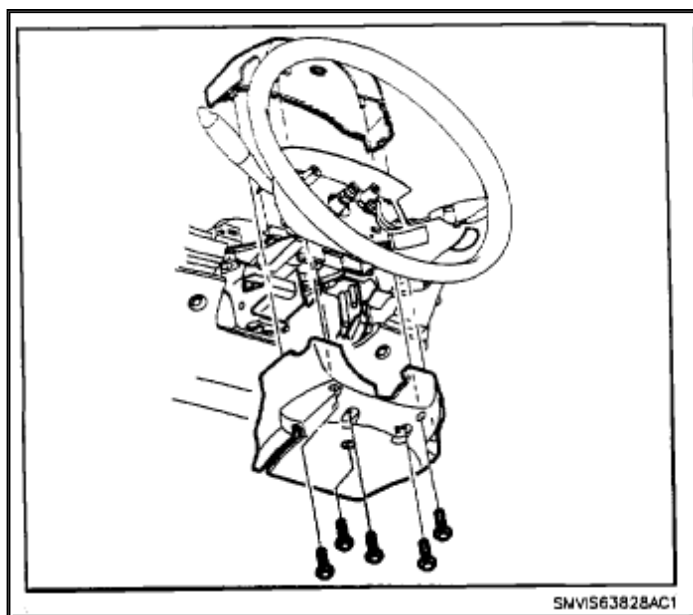
[Zoom](#)[Sized for Print](#)

40. Install steering column upper and lower shroud panels and shroud fasteners.

Torque:

Steering Column Shroud Fasteners: 1.5 Nm (13 in-lbs)

41. Install lock cylinder bezel.
42. Connect negative battery cable.

Torque:

Battery Terminal Bolt: 17 Nm (13 ft-lbs)

43. Verify proper function of ignition lock cylinder.

© 2010 ALLDATA LLC. All rights reserved.

[Terms of Use](#)