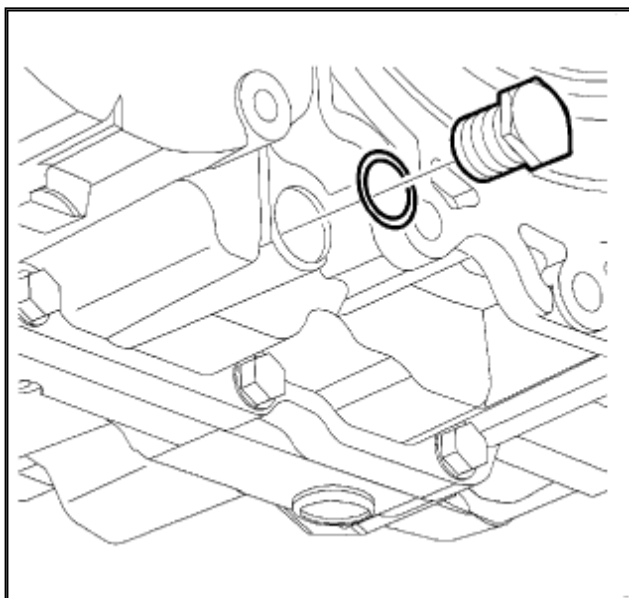

[Select Vehicle](#) | [New TSBs](#) | [Technician's Reference](#)

Component Search:

OK

 [Conversion Calculator](#)**2007 Chevy Truck Equinox FWD V6-3.4L**[Vehicle Level](#) → [Transmission and Drivetrain](#) → [Automatic Transmission/Transaxle](#) → [Fluid - A/T](#) → [Service and Repair](#) ←**Service and Repair**[Notes](#)**Transaxle Fluid Replacement****Removal Procedure**

Zoom

Sized for Print

1. Raise and support the vehicle. Refer to [Vehicle Lifting](#).
2. Remove the drain plug and drain fluid. Allow at least 5 minutes for the fluid to drain completely.
3. Remove the gasket from the drain plug and discard.

Installation Procedure

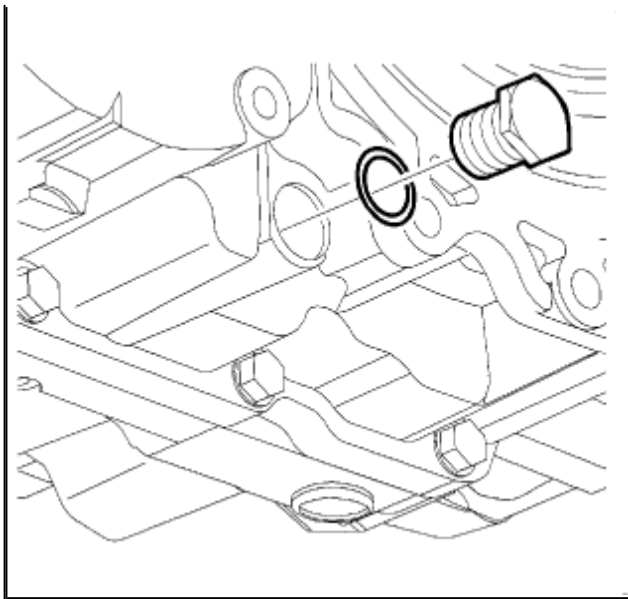

Zoom

Sized for Print

1. Install the new gasket on the drain plug. **Notice:** Refer to Component Fastener Tightening Notice.
2. Install the drain plug. **Tighten the drain plug to 40 N.m (30 lb ft).**
3. Make sure vehicle is level.
4. Remove the fluid level indicator located behind the front transaxle mount. **Notice:** Do not remove the 3rd gear anchor band bolt located on top of the transmission for checking fluid or adding fluid. Removing the bolt will dislocate internal components and require the transmission to be removed from the vehicle and disassembled for repair. **Important: Dexron(R)III automatic transmission fluid is not compatible with this transaxle. If Dexron(R)III ATF is used, transaxle failure will result. Refer to Sealers, Adhesives, and Lubricants.**
5. Add approximately 3.1 L (3.3 Qt) of GM T-IV fluid to the transaxle, using the fluid level indicator location. **Important: If the check is necessary at a low oil temperature of 30-40°C (86-104°F), perform check using the COLD range on the level gage. However, the fluid must be re-checked at the proper fluid temperature.**
6. Start engine and operate vehicle until transaxle fluid temperature reaches **60-70°C (140-158°F).**
7. Apply parking brake.
8. Depress brake pedal and move shift lever slowly through all gear ranges from park (P) to low (L), pausing for about **3 seconds** in each range. Return shift lever to park (P) range at idle condition.
9. Pull level gauge out again and check if fluid level is within the HOT range.
10. If fluid is not within the correct level, adjust accordingly:
 1. If fluid is below the HOT range, add enough to bring it up to the correct level.
 2. If fluid is above HOT range, drain excess fluid.
11. Install the fluid level indicator.

© 2010 ALLDATA LLC. All rights reserved.
[Terms of Use](#)