

1994 Chevy Truck C 1500 Truck 2WD V6-262 4.3L VIN Z

[Vehicle Level](#) → [Maintenance](#) → [Tune-up and Engine Performance Checks](#) → [Ignition Timing](#) → [Technical Service Bulletins](#) → [Ignition - Timing Connector Location Change](#) ←

Ignition - Timing Connector Location Change

[Notes](#)

Group Ref.: Engine
Bulletin No.: 366002
Date: January, 1994

INFORMATION

SUBJECT:
TIMING CONNECTOR LOCATION CHANGE

MODELS:
1994 CHEVROLET AND GMC C/K TRUCKS WITH GASOLINE ENGINES

The timing connector, which can be disconnected to return engine timing to base for adjustment purposes, has been moved from the engine compartment to inside the cab. This new location is not currently reflected in the Service or Owner's Manual.

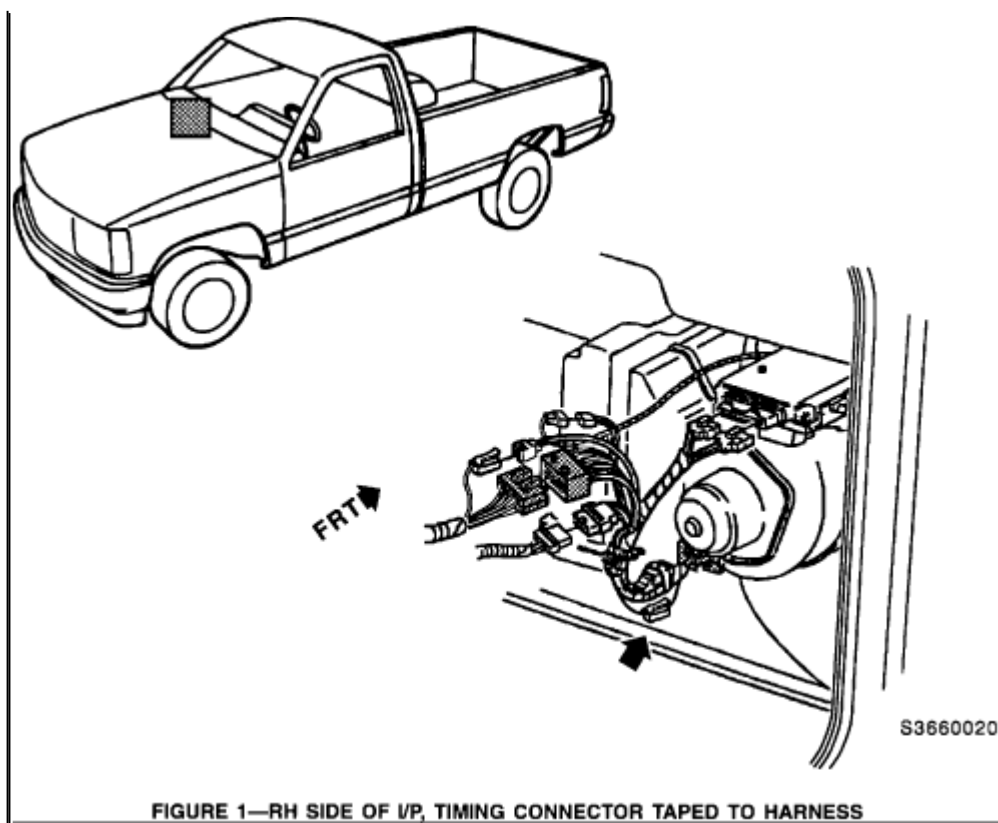

[Zoom](#)[Sized for Print](#)

The new location is under the dash directly below the glove compartment. The tan/black wire is routed for a short distance outside of a large wiring harness. This large harness is routed between the heater blower motor and evaporator case. The timing connector is taped to the wire bundle (Figure 1).