

[Home](#) | [Account](#) | [Contact ALLDATA](#) | [Log Out](#) | [Help](#)

PAUL REDEHOFT

[Select Vehicle](#) | [New TSBs](#) | [Technician's Reference](#) Component Search: 

OK

 Conversion Calculator**2002 Buick Truck Rendezvous V6-3.4L VIN E**[Vehicle Level](#) → [Windows and Glass](#) → [Front Door Window Regulator](#) → [Service and Repair](#) ←

## Service and Repair

[Notes](#)

### Window Regulator Replacement - Front Door

#### Removal Procedure

1. Remove the front door [trim panel](#). Refer to [Trim Panel Replacement - Side Front Door \(Aztek\)](#) ([See: Body and Frame\Doors, Hood and Trunk\Front Door Panel\Service and Repair\Front Door Panel Replacement\Trim Panel Replacement - Side Front Door \(Aztek\)](#)) [Trim Panel Replacement - Side Front Door \(Rendezvous\)](#) ([See: Body and Frame\Doors, Hood and Trunk\Front Door Panel\Service and Repair\Front Door Panel Replacement\Trim Panel Replacement - Side Front Door \(Rendezvous\)](#)) .
2. Remove the water deflector. Refer to [Water Deflector Replacement - Front Door \( \)](#) .
3. Disconnect the window from the window regulator carrier plate. Refer to [Window Replacement - Front Door](#) ([See: Front Door Window Glass\Service and Repair](#)) .

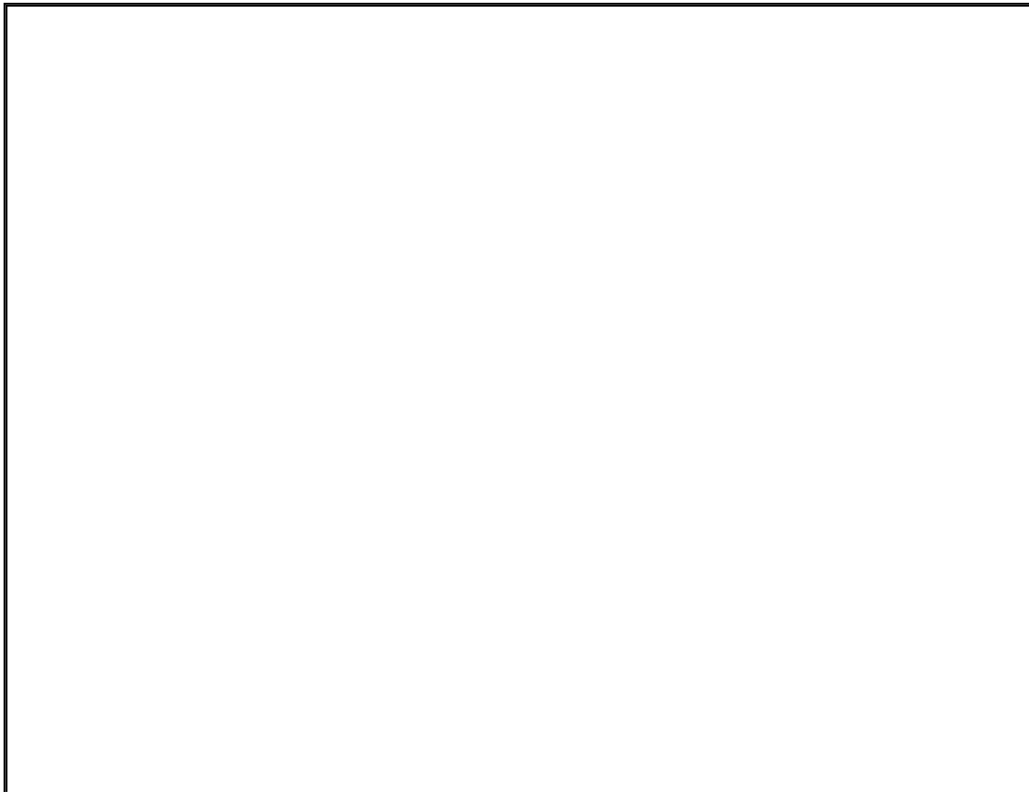

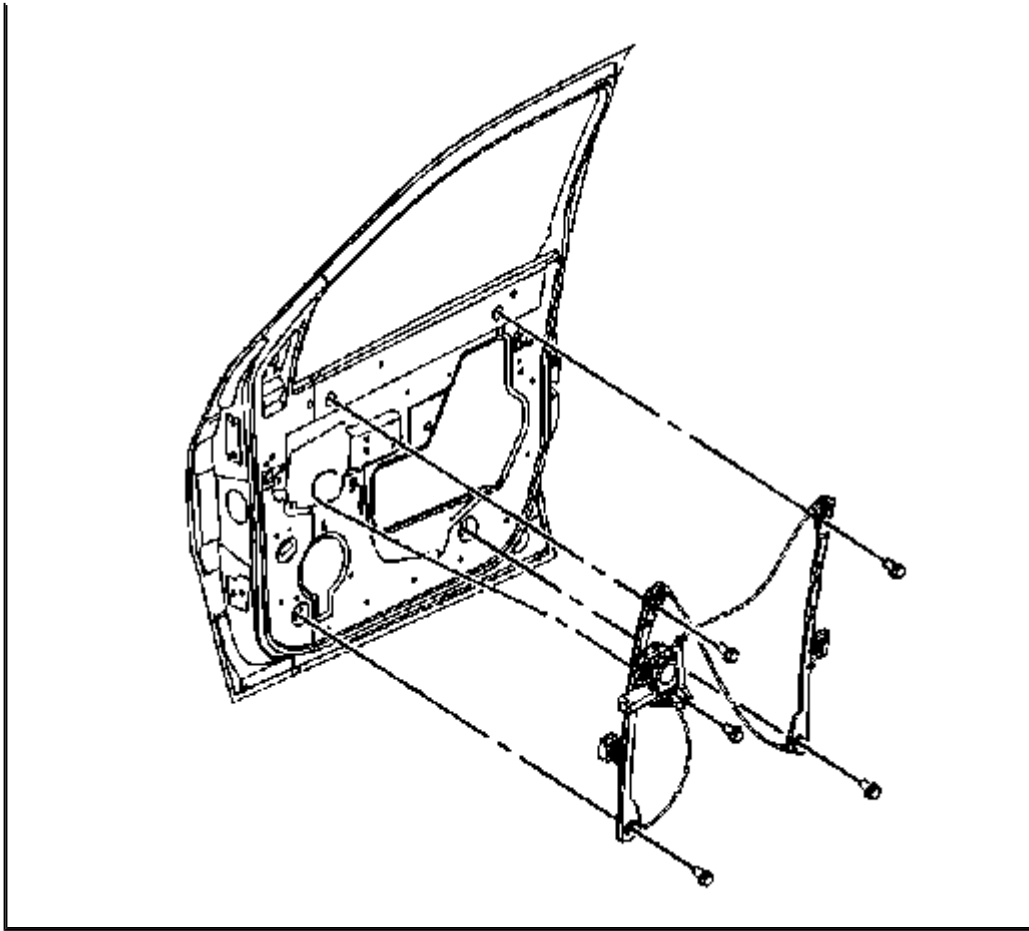

Zoom

Sized for Print

4. Position the window in the full up position and tape it to the window frame.
5. Disconnect the electrical connector from the window regulator motor.
6. Loosen the bolts on the window regulator motor.
7. Loosen the bolts on the window regulator rail.
8. Remove the front window regulator, lifting up and out from the key slots on the door inner panel and through the rear access hole.

### Installation Procedure



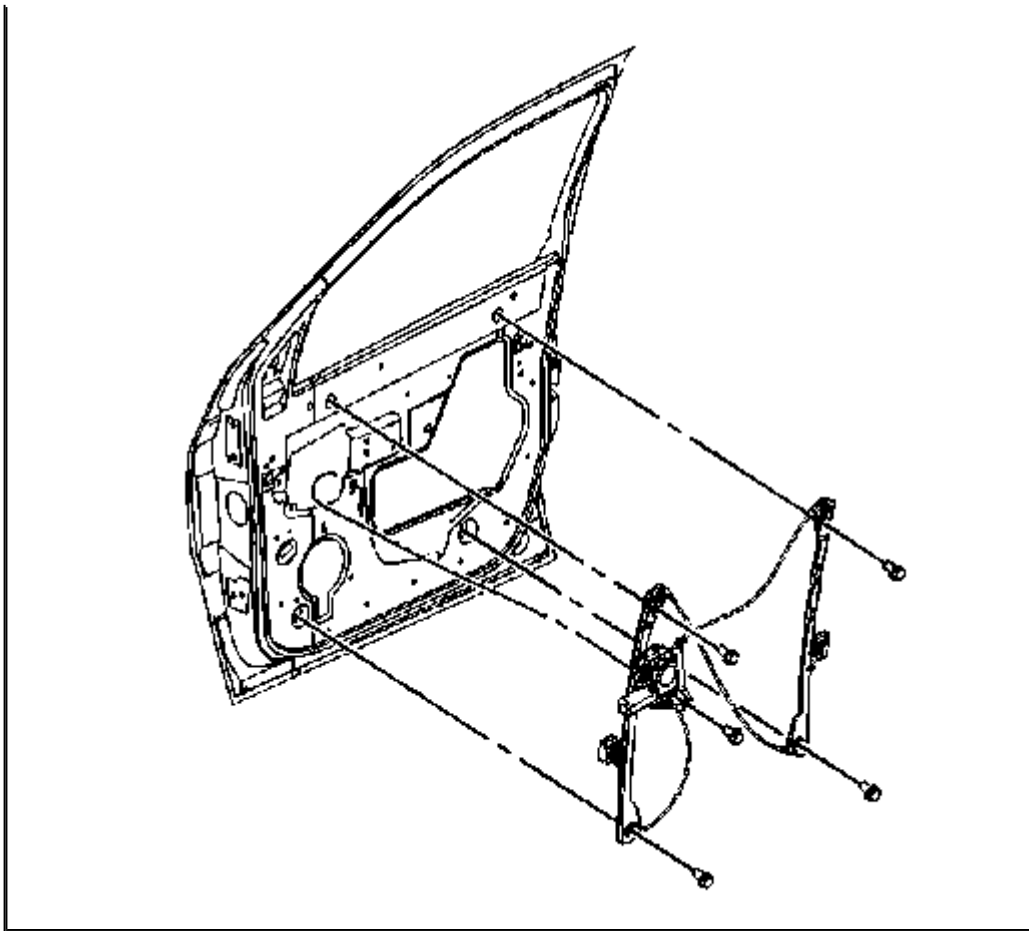

Zoom

Sized for Print

1. Install the front window regulator bolts half way into the rear window regulator motor and the rail.
2. Position the front window regulator rail through the rear access hole first.
3. Position the front window regulator motor through the rear access hole.  
**Notice:** Refer to Fastener Notice in Cautions and Notices.
4. Install the front window regulator into the key slots. Attach the regulator to the motor and the rail. Secure the regulator with bolts. **Tighten the bolts to 11N.m (97 lb in).**
5. Remove the tape and position the front window to the regulator carrier plate.
6. Connect the window to the regulator carrier plate. Refer to Window Replacement - Front Door ([See: Front Door Window Glass\Service and Repair](#)) .
7. Connect the electrical connector to the front window regulator motor.
8. Install the water deflector. Refer to Water Deflector Replacement - Front Door ( ) .
9. Install the [trim panel](#). Refer to Trim Panel Replacement - Side Front Door (Aztek) ([See: Body and Frame\Doors, Hood and Trunk\Front Door Panel\Service and Repair\Front Door Panel Replacement\Trim Panel Replacement - Side Front Door \(Aztek\)](#)) Trim Panel Replacement - Side Front Door (Rendezvous) ([See: Body and Frame\Doors, Hood and Trunk\Front Door Panel\Service and Repair\Front Door Panel Replacement\Trim Panel Replacement - Side Front Door \(Rendezvous\)](#)) .

© 2010 ALLDATA LLC. All rights reserved.  
[Terms of Use](#)