

2002 Chrysler Truck Voyager V6-3.3L VIN R

[Vehicle Level](#) → [Heating and Air Conditioning](#) → [Receiver Dryer](#) → [Service and Repair](#) ←

Service and Repair

[Notes](#)

REMOVAL

WARNING: REFER TO THE APPLICABLE WARNINGS AND CAUTIONS FOR THIS SYSTEM BEFORE PERFORMING THE FOLLOWING OPERATION.

1. Recover the [refrigerant](#) from the refrigerant system.
2. Remove the air cleaner housing from the right side of the engine compartment.

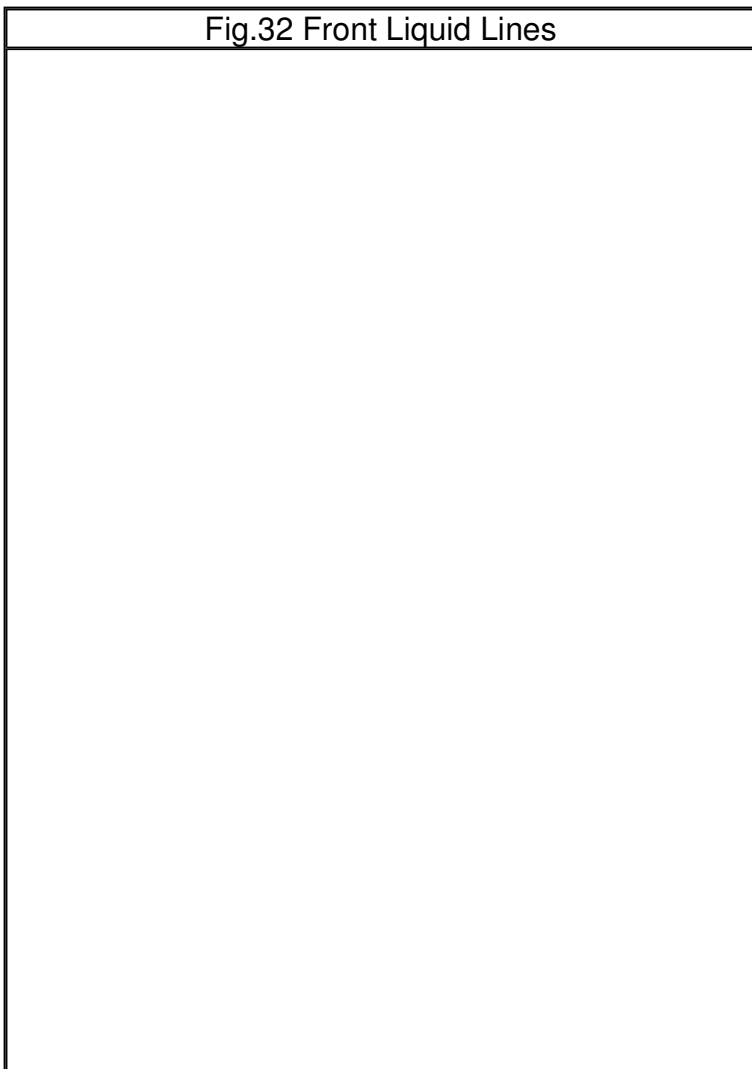

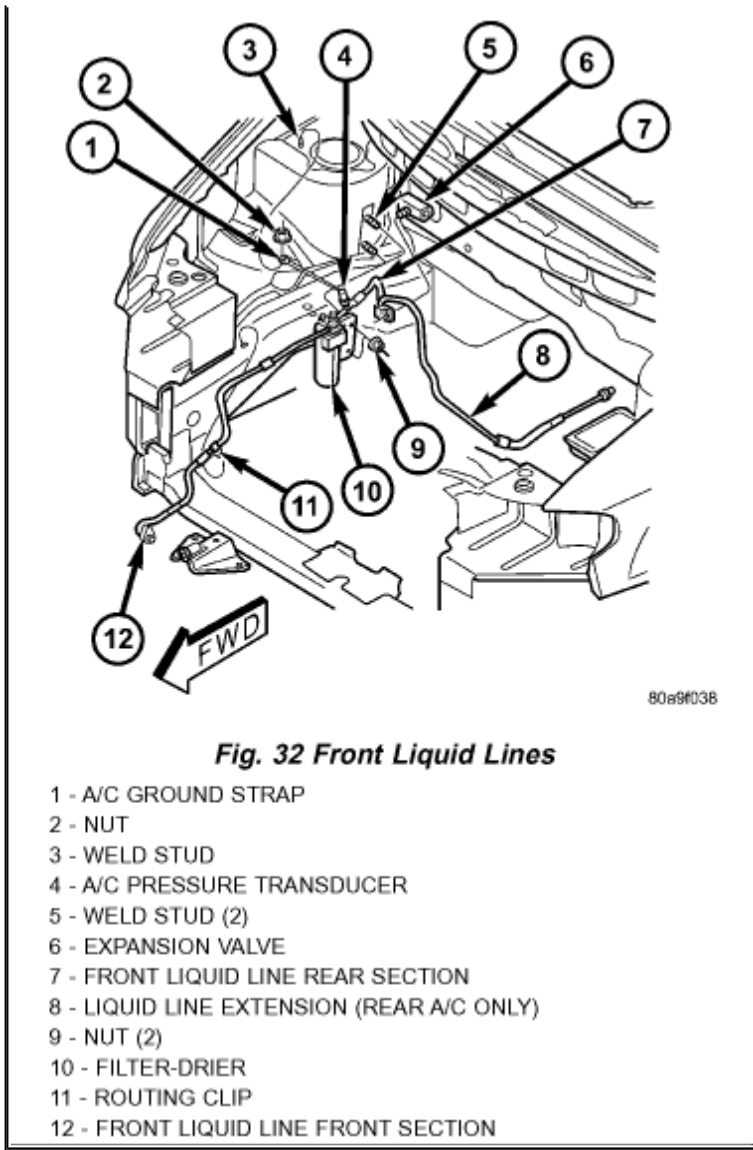

Zoom

Sized for Print

3. Remove the screw that secures the liquid line front section fitting to the top of the filter-drier.
4. Disconnect the liquid line fitting from the filter-drier inlet port.
5. Remove the seal from the liquid line fitting and discard.
6. Install plugs in, or tape over the opened liquid line fitting and the filter-drier inlet port.
7. Remove the screw that secures the liquid line rear section fitting to the top of the filter-drier.
8. Disconnect the liquid line fitting from the filter-drier outlet port.
9. Remove the seal from the liquid line fitting and discard.
10. Install plugs in, or tape over the opened liquid line fitting and the filter-drier outlet port.
11. Remove the two nuts that secure the filter-drier mounting bracket to the weld studs on the side of the right front strut tower.
12. Remove the filter-drier and mounting bracket unit from the studs.

INSTALLATION

NOTE: If the filter-drier is being replaced, add **30 milliliters (1 fluid ounce)** of [refrigerant oil](#) to the [refrigerant](#) system. Use only refrigerant oil of the type recommended for the compressor in the vehicle.

1. Position the filter-drier and mounting bracket unit onto the weld studs on the side of the right front strut tower.
2. Install and tighten the two nuts that secure the filter-drier mounting bracket to the studs. Tighten the nuts to **10 Nm (89 in. lbs.)** .
3. Remove the tape or plugs from the liquid line rear section fitting for the filter-drier and the filter-drier outlet port.
4. Lubricate a new rubber O-ring seal with clean [refrigerant oil](#) and install it on the liquid line fitting.
5. Reconnect the liquid line fitting to the filter-drier outlet port on the top of the filter-drier.
6. Install and tighten the screw that secures the liquid line fitting to the filter-drier. Tighten the screw to **2 Nm (18 in. lbs.)** .
7. Remove the tape or plugs from the liquid line front section fitting for the filter-drier and the filter-drier inlet port.
8. Lubricate a new rubber O-ring seal with clean [refrigerant oil](#) and install it on the liquid line fitting.
9. Reconnect the liquid line fitting to the filter- drier inlet port on the top of the filter-drier.
10. Install and tighten the screw that secures the liquid line fitting to the filter-drier. Tighten the screw to **2 Nm (18 in. lbs.)** .
11. Reinstall the air cleaner housing into the right side of the engine compartment.
12. Evacuate the [refrigerant](#) system.
13. Charge the [refrigerant](#) system.