

**2000 Jeep Truck Wrangler L4-2.5L VIN P**

[Vehicle Level](#) → [Transmission and Drivetrain](#) → [Manual Transmission/Transaxle](#) → [Shift Linkage](#) → [Shift Boot](#) → [Service and Repair](#) ←

**Service and Repair**[Notes](#)**SHIFT BOOT****REMOVAL**

1. Using a trim stick C-4755 or equivalent, pry the shift boot from the bezel.
2. Using a small flat blade, pry the shift pattern insert from the shift knob.

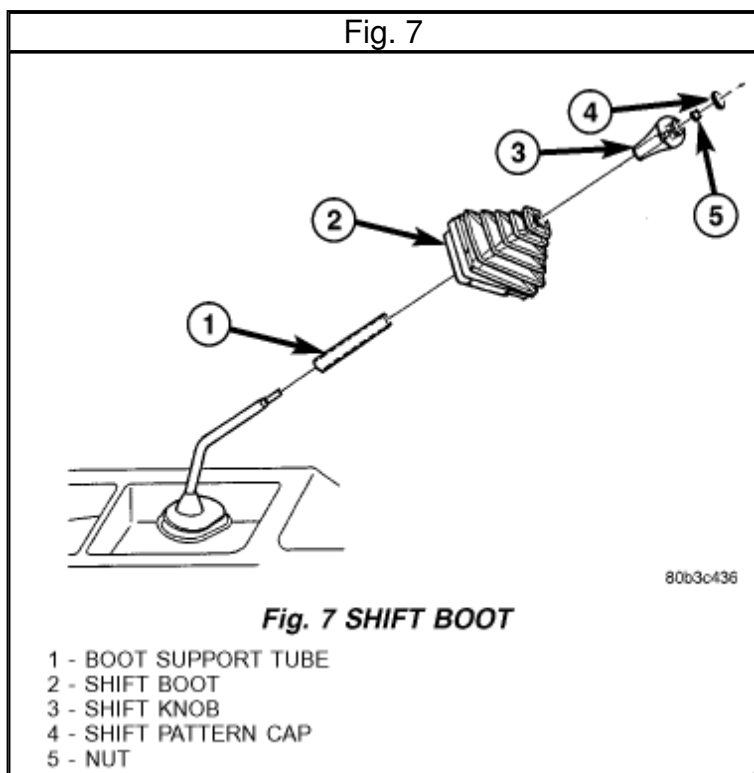

Zoom

Sized for Print

3. Remove the nut attaching the shift knob to the shift lever (Fig. 7).
4. Remove the knob and slide the shift boot from the shift lever.

**INSTALLATION**

1. Slide the shift boot over the shift lever.

2. Snap the shift boot into place in the center console.
3. Position the shift knob on the lever, install the nut and tighten to **34 N.m (25 ft.lbs.)**.
4. Position the shift pattern insert on the knob and press into place.

© 2010 ALldata LLC. All rights reserved.  
[Terms of Use](#)