

2001 Toyota Echo L4-1.5L (1NZ-FE)

Vehicle Level → Transmission and Drivetrain → Manual Transmission/Transaxle → Service and Repair → Removal and Installation ←

Removal and Installation

[Notes](#)

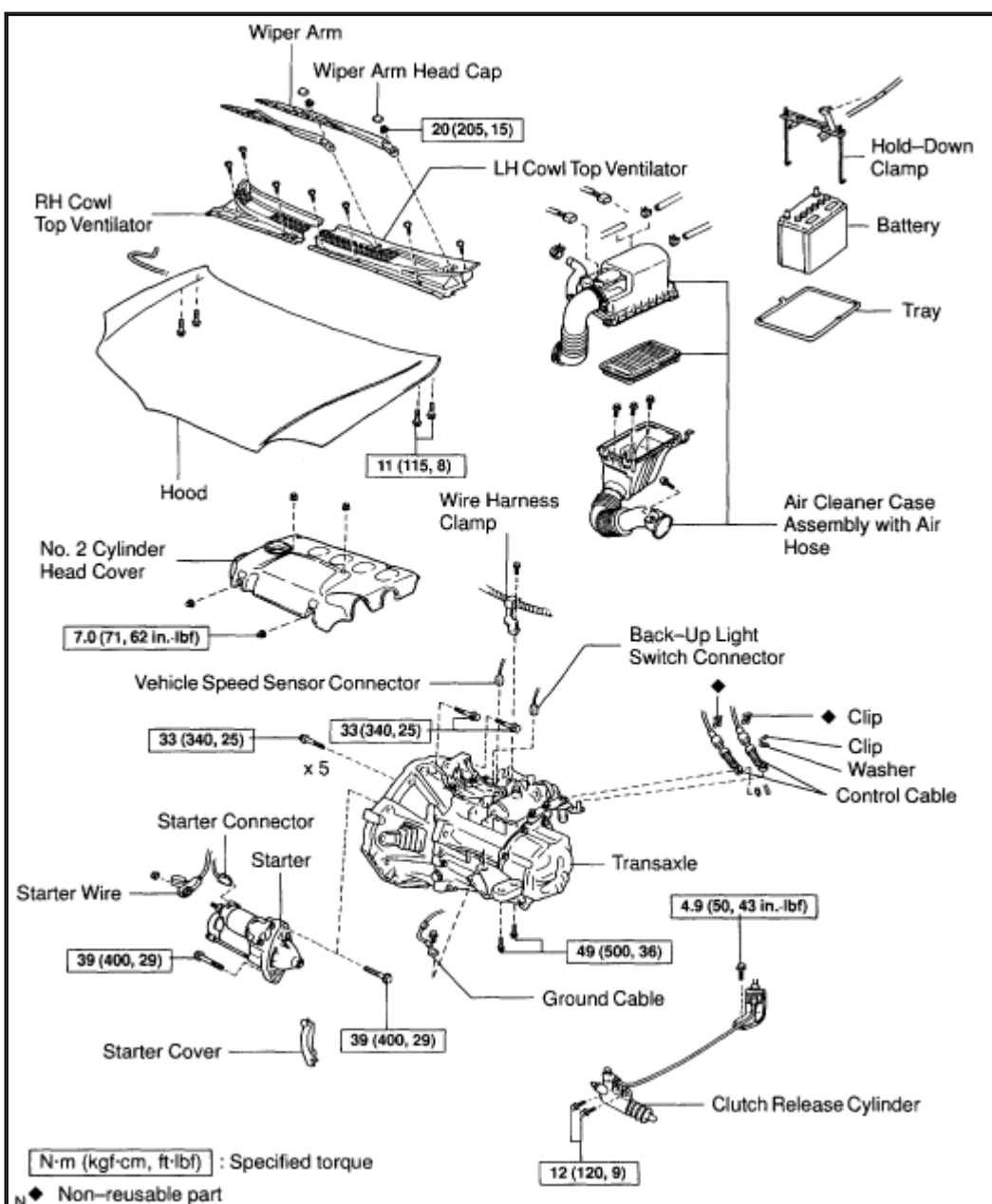

Zoom

Sized for Print

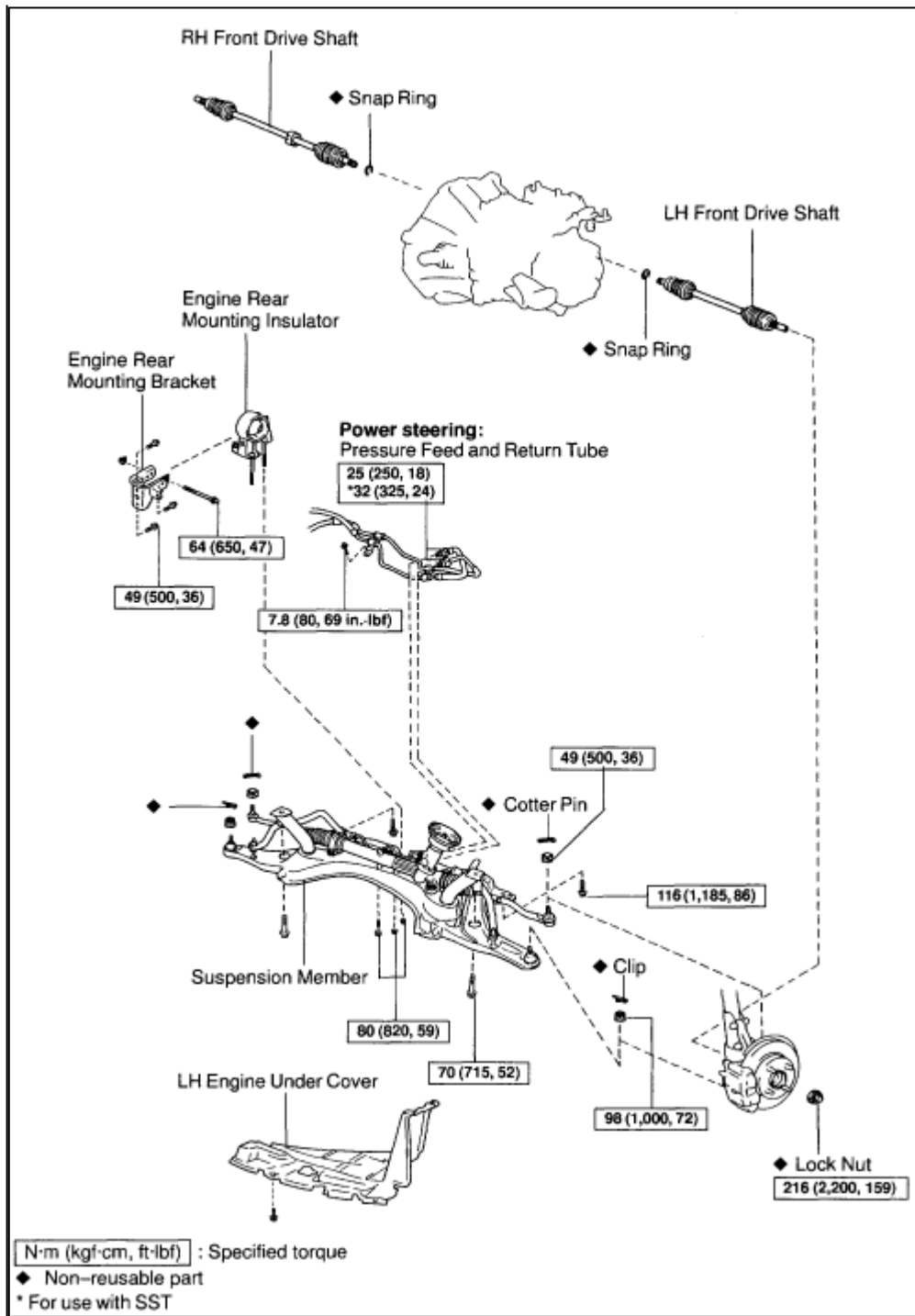

Zoom

Sized for Print

REMOVAL

1. REMOVE HOOD **HINT:** At the time of installation, please refer to the following item. Adjust the hood.
2. REMOVE WIPER ARM **HINT:** At the time of installation, please refer to the following item. Adjust the installation position of the wiper arms.

3. REMOVE RH AND LH COWL TOP VENTILATOR LOUVERS
4. REMOVE NO. 2 CYLINDER HEAD COVER Remove the 4 nuts and No. 2 cylinder head cover. Torque: **7.0 Nm (71 kgf-cm, 62 inch lbs.)**
5. REMOVE BATTERY AND AIR CLEANER [CASE](#) ASSEMBLY WITH AIR HOSE

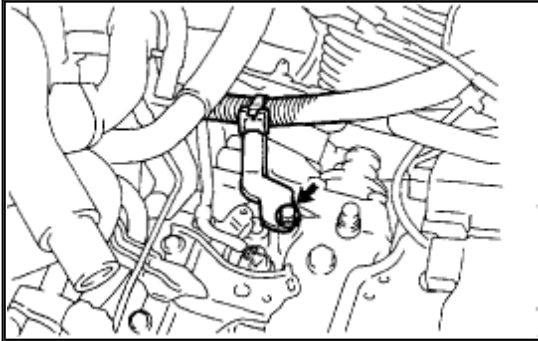
[Zoom](#)[Sized for Print](#)

6. DISCONNECT WIRE HARNESS FROM TRANSAXLE Remove the set bolt of the wire harness clamp.
7. DISCONNECT CONTROL CABLE
 - a. Remove the 2 clips and washers.
 - b. Remove the 2 clips and disconnect the control cables from the transaxle.

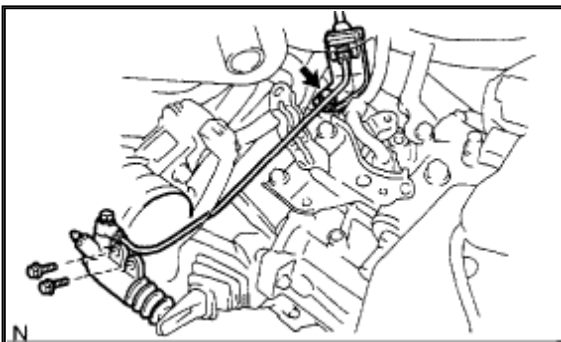
[Zoom](#)[Sized for Print](#)

8. DISCONNECT CLUTCH RELEASE CYLINDER
 - a. Remove the set bolt of the clutch line. Torque: **4.9 Nm (50 kgf-cm, 43 inch lbs.)**
 - b. Remove the 2 set bolts of the clutch release cylinder. Torque: **12 Nm (120 kgf-cm, 9 ft. lbs.)**

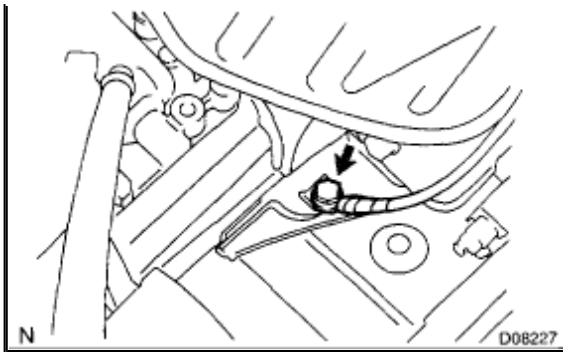

[Zoom](#)[Sized for Print](#)

9. DISCONNECT GROUND CABLE Remove the set bolt of the ground cable from the engine left mounting bracket.
10. DISCONNECT BACK-UP LIGHT SWITCH AND VEHICLE SPEED SENSOR CONNECTORS

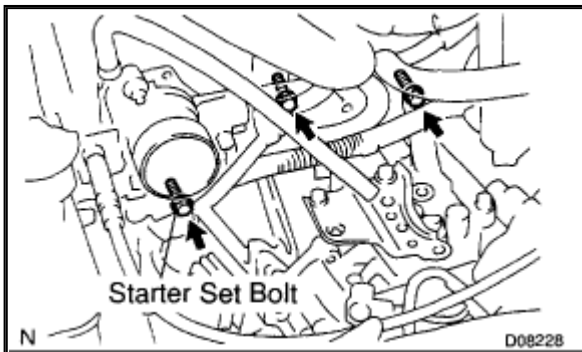
[Zoom](#)[Sized for Print](#)

11. REMOVE 2 TRANSAXLE UPPER SIDE MOUNTING BOLTS Torque: **33 Nm (340 kgf-cm, 25 ft. lbs.)**
12. REMOVE STARTER SET BOLT Torque: **39 Nm (400 kgf-cm, 29 ft. lbs.)**
13. ATTACH ENGINE SLING DEVICE TO ENGINE HANGER

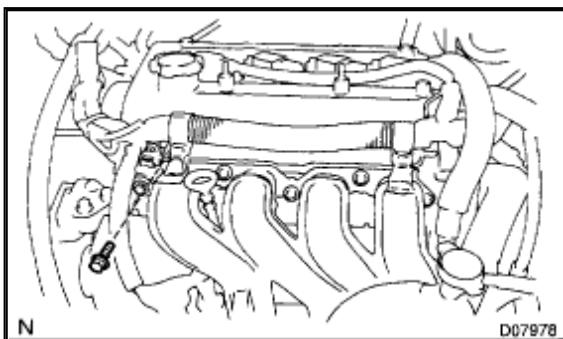
[Zoom](#)[Sized for Print](#)

- a. Remove the bolt.

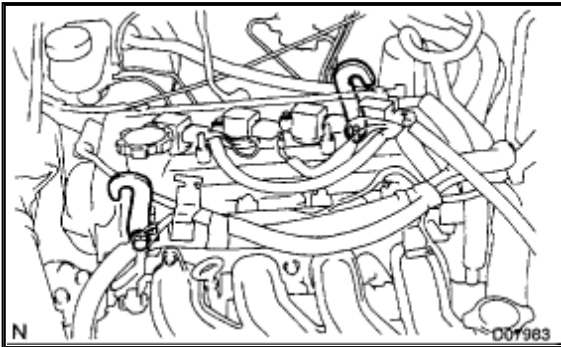

Zoom

Sized for Print

- b. Install the 2 No. 1 engine hangers with the bolts in the correct direction.
Parts No.: No. 1 engine hanger: 12281-21010 Bolt: 91642-81025 Torque: **40 Nm (400 kgf-cm, 29 ft. lbs.)**
- c. Attach the engine chain hoist to the engine hangers. **CAUTION:** Do not attempt to hang the engine by hooking the chain to any other part.

14. RAISE VEHICLE **CAUTION:** Make sure that the vehicle is securely supported.
15. REMOVE LH ENGINE UNDER COVER

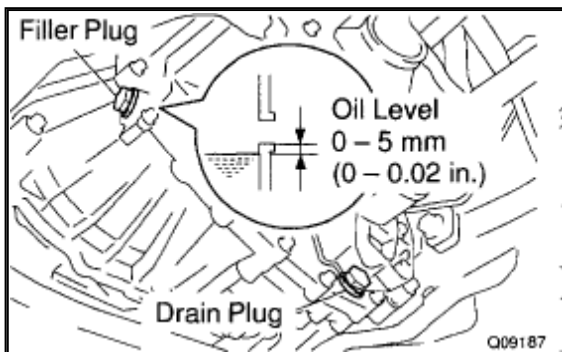

Zoom

Sized for Print

16. DRAIN TRANSAXLE OIL Oil grade: **API GL-4 or GL-5** Viscosity: **SAE 75W-90** Capacity: **1.9 liters (2.0 US qts, 1.7 Imp. qts)** Torque: **39 Nm (400 kgf-cm, 29 ft. lbs.)**
17. REMOVE RH AND LH FRONT DRIVE SHAFTS
18. REMOVE SUSPENSION MEMBER
- Remove the 2 set nuts and bolt of the engine rear mounting insulator from the suspension member.
 - Disconnect the sliding yoke.
 - Power steering: Disconnect the pressure feed and return tubes.
 - Power steering: Disconnect the tube clamp.

e. Remove the suspension member.

19. JACK UP TRANSAXLE SLIGHTLY Using a transmission jack, support the transaxle.

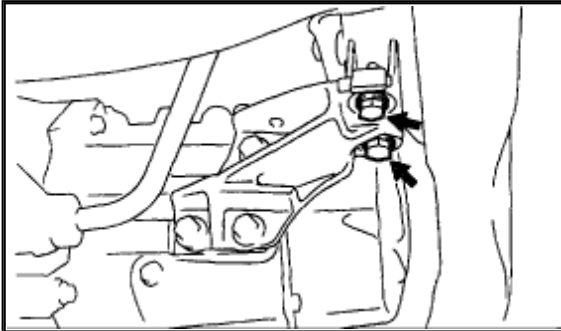

Zoom

Sized for Print

20. DISCONNECT ENGINE LEFT MOUNTING BRACKET FROM ENGINE LEFT MOUNTING INSULATOR Remove the 2 bolts. Torque: **49 Nm (500 kgf-cm, 36 ft. lbs.)**

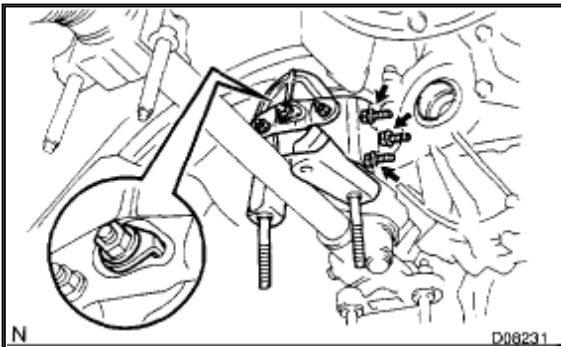

Zoom

Sized for Print

21. REMOVE ENGINE REAR MOUNTING INSULATOR AND BRACKET

- a. Remove the bolt, nut and engine rear mounting insulator. Torque: **64 Nm (650 kgf-cm, 47 ft. lbs.)**
- b. Remove the 3 bolts and engine rear mounting bracket. Torque: **49 Nm (500 kgf-cm, 36 ft. lbs.)**

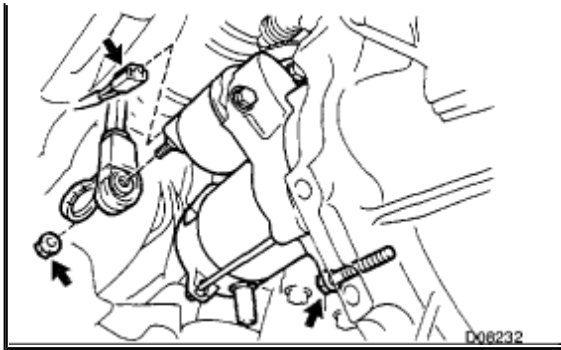

[Zoom](#)[Sized for Print](#)

22. REMOVE STARTER

- a. Remove the bolt, starter cover and starter. Torque: **39 Nm (400 kgf-cm, 29 ft. lbs.)**
- b. Disconnect the starter connector.
- c. Remove the nut and starter wire.

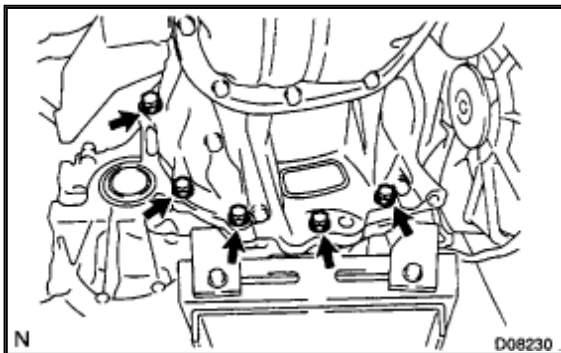
[Zoom](#)[Sized for Print](#)

23. REMOVE 5 TRANSAXLE LOWER SIDE MOUNTING BOLTS Torque: **33 Nm (340 kgf-cm, 25 ft. lbs.)**

24. REMOVE TRANSAXLE Lower the engine left side and remove the transaxle from the engine. **HINT:** At the time of installation, please refer to the following items.

- Align the [input shaft](#) with the [clutch disc](#) and install the transaxle to the engine.
- Temporarily tighten the transaxle mounting bolts.

INSTALLATION

Installation is in the reverse order of removal.

HINT: After installation, check and inspect items as follows.

- Front wheel alignment.
- Do the road test.

© 2010 ALLDATA LLC. All rights reserved.
[Terms of Use](#)