

Camshaft**Special Tool(s)**

 <p>ST1715-A</p>	<p>Holding Tool, Camshaft 303-446 (T93P-6256-AHR)</p>
---	---

Material

Item	Specification
<p>Super Premium SAE 5W-20 Engine Oil XO-5W20-QSP or equivalent</p>	<p>WSS-M2C153-H</p>

Removal

1. Remove the roller followers. For additional information, refer to [Roller Followers](#) in this section.
2. Remove the RH timing chain for the RH side and both timing chains for the LH side. For additional information, refer to [Timing Drive Components](#) in this section.
3. Install the special tool.

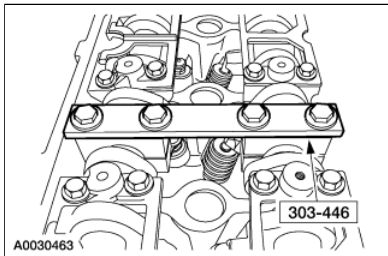

4. Remove the exhaust camshaft sprocket (6250) and the intake camshaft bolt, washer and spacer.

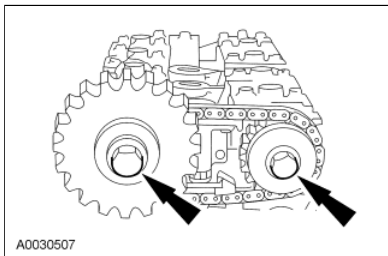

5. Remove the special tool.

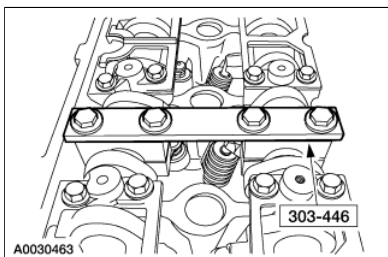

6. Compress the tensioner (6L266) and install a lock pin.

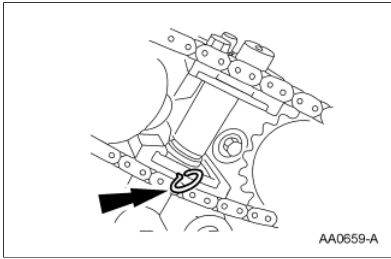

7. Remove the timing chain, the sprocket, and intake camshaft sprocket spacer.

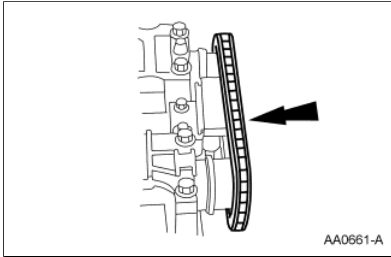

8. **NOTE:** LH shown; RH similar.

Remove the bolts.

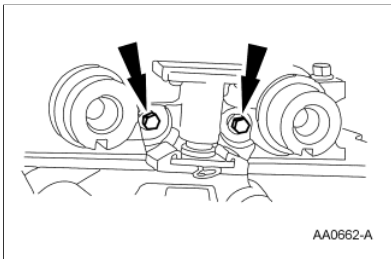

9. **⚠ CAUTION:** The outer bolts on the outer cam bearing cap (exhaust) are longer and must be returned to the same location or engine damage may occur.

NOTE: Identify the camshaft to cylinder head location. Caps are not interchangeable.

Remove the bolts and the camshaft bearing cap assemblies.

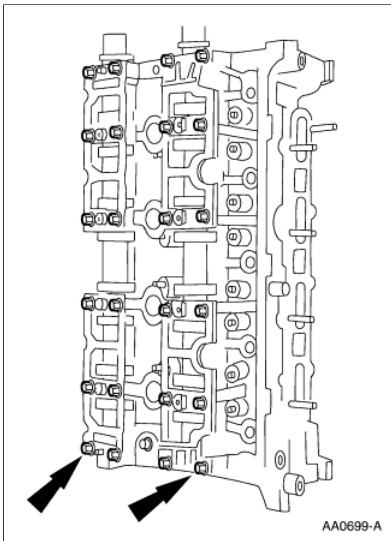

10. Remove the camshafts (6250).

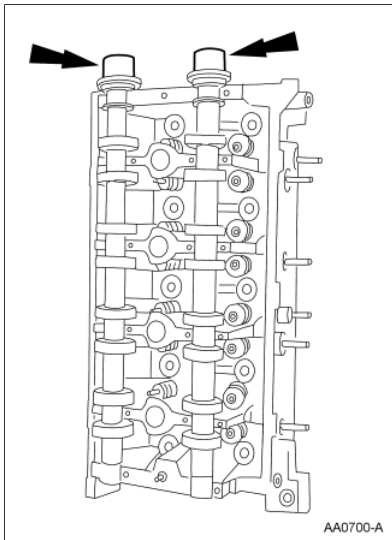
**Installation**

1. **NOTE:** LH shown; RH similar.

Install the camshafts.

- Lubricate the camshafts with clean engine oil.

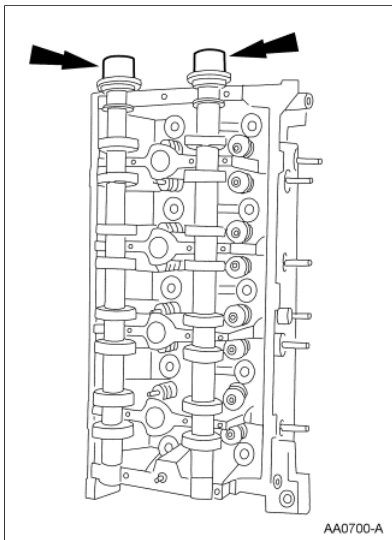

2. Install the camshaft bearing cap assemblies.

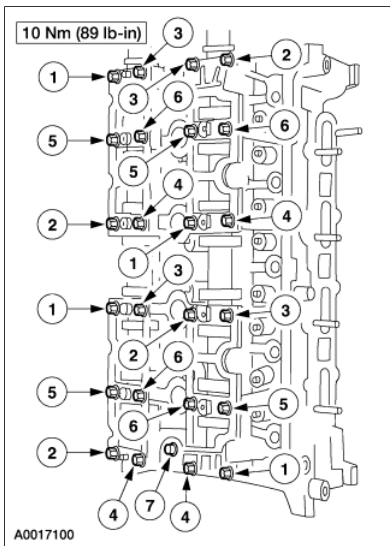

3. Install the bolts.

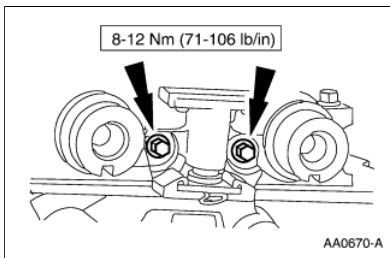

4.  **CAUTION:** Timing marks must be at 12 o'clock and indexed at 6 o'clock.

Install the camshaft sprockets and the chain as an assembly.

5. Remove the lockpin from the chain tensioner.

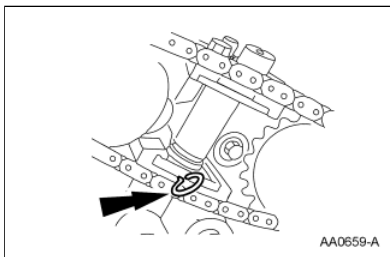

6. Install the special tool.

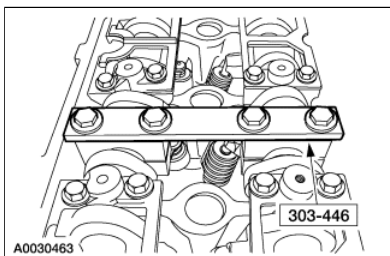

7. Tighten the exhaust camshaft sprocket and the intake camshaft bolt washer and spacer in two stages:
 - Stage 1: Tighten to 40 Nm (30 lb-ft).
 - Tighten an additional 90 degrees.

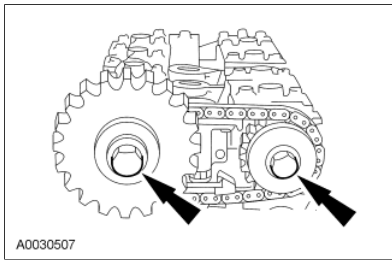

8. Remove the special tool.
 9. Install the RH timing chain for the RH side or both timing chains for the LH side. For additional information, refer to [Timing Drive Components](#) in this section.
 10. Install the roller followers. For additional information, refer to [Roller Followers](#) in this section.
-