

11/10/2010 11:41:36 AM

# ALLDATA

Library Research Services  
Direct Fax: 800-684-4241

Send Via: EMAIL

Feedback ID: 1393994  
Additional Request: N  
Action: MISSING  
Product: PRO Active

To: DAN GRIMWOOD  
ATTN: DAN GRIMWOOD  
Email: jettadan@yahoo.com

Fax #:  
Bus: 812-589-9557  
CSR: rpanelo

# Pages: 10 LRS: rp

| Year | Make        | Model | Engine            | Trans |
|------|-------------|-------|-------------------|-------|
| 2003 | Isuzu Truck | NPR   | L4-4.8L DSL Turbo | A     |

TOC Zone: 35 - Transmission and Drivetrain

Component/Path: Automatic Transmission/Transaxle

Info Type: 34 - TSB INFORMATION

**Additional Info:**

**Problem:** need info on TSB#020730025...also need location of trans module and testing for this tech service bulletin.

---

**Notes**

*If the data received does not meet your needs, call 866-537-1571*

*Thank You for choosing ALLDATA*

Document ID: 1351952

## #02-07-30-025B: Harsh Shifting, Delayed Upshifts with Possible CHECK TRANS Lamp Illuminated, Possible DTC 21 Set (Perform TPS Relearn Procedure) - (Jun 27, 2003)

**Subject:** Harsh Shifting, Delayed Upshifts with Possible CHECK TRANS Lamp Illuminated, Possible DTC 21 Set (Perform TPS Relearn Procedure)



**Models:** 1999-2004 Chevrolet W-Series Medium Duty Tilt Cab Models  
1999-2004 GMC W-Series Medium Duty Tilt Cab Models  
1999-2004 Isuzu NPR/NQR Commercial Medium Duty Models  
with 4HE1 Diesel Engine and Aisin Automatic Transmission

This bulletin is being revised to add model information and to change procedure steps and labor time. Please discard Corporate Bulletin Number 02-07-30-025A (Section 07 -- Transmission/Transaxle).

### Condition

Some customers may comment on harsh shifting and/or delayed upshifts that may or may not be accompanied by a CHECK TRANS lamp illumination.

### Correction

Perform the TPS relearn procedure below.

**Important:** The TCM relearn procedure **MUST** be done after replacement or adjustment of the following components:

- The injection pump
- The engine assembly
- The accelerator pedal
- The accelerator cable
- The throttle position sensor (TPS)
- The kick-down switch
- The TCM
- The transmission

Failure to do this may result in a hard shift, delayed shift, slippage or excessive automatic transmission clutch material wear conditions.

© 2010 General Motors. All rights reserved.

The TPS relearn procedure should also be done when the following conditions occur:

- Harsh shifting
- Delayed upshifts
- Take-off in fail-safe mode (2nd gear)
- Flashing Check Trans light (no stored codes)

## TPS Relearn Procedure

If there is a change in the relationship between the TPS and the injection pump rack voltage, there will be a noticeable change in the shift pattern of the transmission. The TPS relearn is needed to provide the TCM with a correlation value between the TPS sensor and the injection pump rack position. It is this learned value that the TCM uses to produce the shift pattern for the transmission based on the TPS input during vehicle operation.

The difference in the shift pattern can be anything such as harsh/delayed shift, no shift and slipping (in cases where the TPS sensor voltage exceeds 0.15 volts at WOT, or 4.8 volts at IDLE, the TCM will set DTC 21).

This shift pattern change will not cause immediate damage to the transmission. It may result in excessive clutch wear over a prolonged period.

**Important:** There are six simple, but necessary steps to this procedure. Follow these steps in order. The preliminary steps are essential and important to the success of the relearn procedure. If the preliminary steps are NOT followed, the relearn procedure will NOT work.

1. Preliminary Steps
2. TCM-TPS Clearing
3. TCM-DTC Clearing
4. Memorize wide open throttle (WOT) Voltage
5. Memorize IDLE Voltage
6. Verifying TPS Values Accepted

### **Preliminary Steps**

1. Turn the idle control knob fully counterclockwise (OFF).
2. Make sure the idle lever on the injection pump rests against the idle stop.
3. There must be 5-10 mm (0.197-0.394 in) of accelerator pedal free play. If not, adjust the accelerator cable to correct pedal free play). Refer to Accelerator Linkage Adjustment and Adjustment of Accelerator Pedal Stopper Bolt in this bulletin.
4. Verify accelerator pedal stop adjustment. There must be 0-2 mm (0-0.078 in) of clearance between the stopper and the back of the pad. Refer to Adjustment of Accelerator Pedal Stopper Bolt in this bulletin.
5. Press the accelerator pedal by hand to the floor. Make sure the engine control lever on the injection pump contacts the full throttle stop bolt.
6. Press the accelerator pedal by hand and make sure the kick down switch makes contact between 95-100 percent throttle (You can hear the switch click). Refer to Kick Down Switch (Adjustment) in this bulletin.
7. Verify TPS voltage.
  - Connect the Tech 2 and scroll to the Data Display screen. As an alternate method, connect a DVOM to TCM connector B-229, pin #5 (red/white wire) and verify voltage.

- Depress the accelerator pedal to WOT.
- Make sure the TPS voltage reads between 0.8 volt and 1.6 volts.
- Release the accelerator pedal to the idle position and ensure the voltage reads between 4.1 and 4.5 volts.
- Disconnect the Tech 2, or DVOM.

## TCM-TPS Clearing

1. Shift the transmission lever to position "1".
2. Turn the ignition switch to the ON position but do not start the engine.
3. Turn the overdrive switch on the shifter off. The O/D OFF lamp will be illuminated on the instrument panel.
4. With your foot, slowly depress and hold the accelerator pedal to WOT until you hear the kick-down switch click (95-100 percent throttle) and hold.
5. Depress and hold the brake pedal with your other foot. The CHECK TRANS lamp should begin flashing within ten seconds.
  - On early TCM's (1999), the CHECK TRANS lamp will flash five times.
  - On later TCMs (2000-up), the CHECK TRANS lamp will flash five times slow and then six times fast.
6. Slowly release both pedals.
7. Turn the ignition OFF.

## TCM-DTC Clearing

1. Shift the transmission to Neutral.
2. Turn the O/D on.

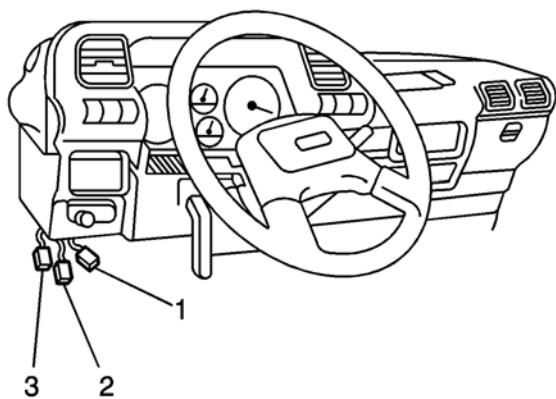

3. Jump pins 1 and 3 of the green TCM data link connector (DLC) (1). For 2000 MY and up vehicles, jump pins 4 and 11 in the 16- pin DLC connector.
4. Turn the ignition ON. The CHECK TRANS light will flash.
5. Press the accelerator pedal to WOT until you hear the kickdown switch click and hold it (95-100 percent throttle).

6. Press and hold the brake pedal. The CHECK TRANS light will flash 10 times slow and then flash fast.
7. Release both pedals.

## Memorize WOT Voltage

1. Disconnect the Fast Idle Control Device (FICD) connector (3). This is a 1-pin white connector located near the green TCM-DLC connector at the lower left side of the instrument panel. The connector is wrapped with blue tape.
2. Shift the transmission to Park.
3. With your foot, slowly depress the accelerator pedal to WOT until you hear the kick down switch click and continue to hold the pedal (95-100 percent throttle).
4. Depress and hold the brake pedal with your other foot. The CHECK TRANS lamp should illuminate for three seconds, then slowly flash three times and then flash quickly.
5. Release both pedals.

## Memorize IDLE Voltage

1. Start the engine.
2. Depress the accelerator pedal to approximately 1000 RPM three times slowly. Allow the pedal to return to its resting position each time.
3. Turn the ignition OFF.
4. Remove the jumper wire from the green TCM-DLC.
5. Connect the white 1-pin FICD connector.

## Verifying TPS Values Accepted

1. Turn the ignition switch to the ON position, but do not start the engine. The CHECK TRANS light will start flashing.
2. With your foot, slowly depress the accelerator pedal to WOT until you hear the kick down switch click and hold it (95-100 percent throttle).
  - If the Relearn Procedure was successful, the CHECK TRANS light will turn off when you release the accelerator pedal.
  - If the CHECK TRANS light continues to flash, you will have to start over from the TCM-TPS Clearing procedure. If the procedure continues to be unsuccessful, verify that there are no conditions with the adjustment of the accelerator pedal, the kick down switch/TPS, the accelerator cable/injection pump or for TCM-DTCs.

## CHECK TRANS Light Operation

The following procedures are for manually pulling TCM DTCs, how to read TCM-DTCs and how to manually clear TCM-DTCs.

## Manually Reading TCM-DTCs

1. Jump between pins 1 and 3 of the green TCM-DLC. For 2000 MY and up vehicles, jump pins 4 and 11 in the 16-pin DLC connector.
2. Turn the ignition ON. The CHECK TRANS light will flash when there is a failure in one of its monitored circuits. The light will turn off as soon as the condition that caused the failure is corrected. The code will be stored in history.

## DTC Notes

- If the lamp flashes on and off, Code 1, there are no DTC stored.
  - The 10s digit of a code is flashed first and then the 1s digit.
  - Each code is flashed three times in a continuous cycle.
  - Codes will flash until the jumper wire is removed.
3. Turn the ignition OFF.
  4. Disconnect the jumper wire.

## Manually Clearing TCM-DTCs

1. Jump between pins 1 and 3 of the green TCM-DLC. For 2000 MY and up vehicles, jump pins 4 and 11 in the 16-pin DLC connector.
2. Shift the transmission to Neutral.
3. Turn the ignition ON.
4. Press the accelerator pedal until you hear the kickdown switch click and hold it (95-100 percent throttle).
5. Press and hold the brake pedal. If the procedure was successful, the CHECK TRANS lamp will flash fast and then slow.

The following procedures are provided if you need to perform adjustments to components needed to perform the Relearn Procedure.

## Adjustment of Accelerator Pedal Stopper Bolt

1. Hold the accelerator pedal pad securely by hand and give it a full stroke.

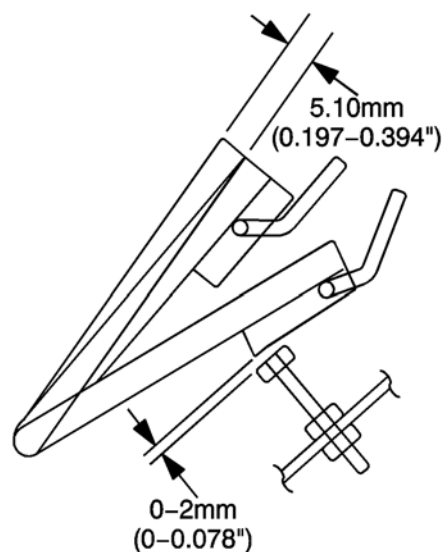

2. Adjust the stopper bolt so that the clearance between the pad stopper bolt and the rear side

- of the pad becomes the specified length (0-2 mm (0-0.078 in) at full stroke).
3. Verify if the accelerator pedal play is in the range of 5 to 10 mm (0.197 to 0.394 in) above the pedal pad.
  4. Press down on the accelerator pedal fully and verify that the engine rotates at its maximum speed with each of the linkage in smooth operation.
  5. In the operating range, the accelerator pedal and the injection pump lever should return to their original position.

## Accelerator Linkage Adjustment

**Important:** Make sure that the hand throttle control knob is in the "off" position.

1. Tilt the cab.

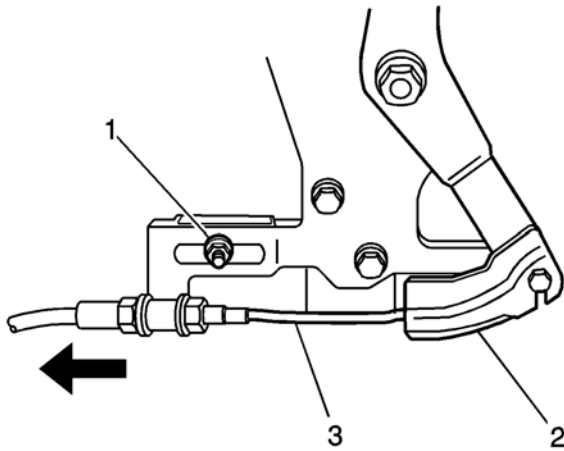

2. Loosen the bolt (1) on the cable bracket.
3. Hold the accelerator lever (2) in the fully closed position and remove slack from the cable (3) by pulling in the direction of the arrow.
4. Tighten the bolt (1).
5. Inspect the cable and pedal assembly for free movement.
6. Lower the cab.

## Kickdown Switch (Adjustment)

The kick down switch is fitted to the accelerator linkage.

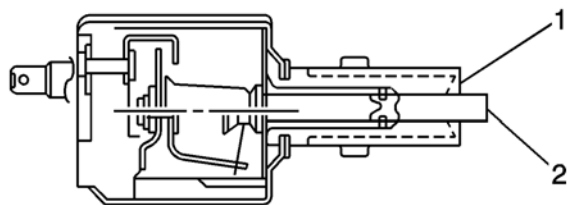

1. Depress the accelerator pedal by hand until the injection pump side opens fully.
2. Adjust the protection level of the kickdown switch so that it may become "on."
3. A "clicking" sound indicates that the kickdown switch is turned to the "on" position (1).

## Warranty Information

For vehicles repaired under warranty, use:

| Labor Operation | Description                   | Labor Time |
|-----------------|-------------------------------|------------|
| J6375           | Perform TPS Relearn Procedure | 0.3 hr     |

GM bulletins are intended for use by professional technicians, NOT a "do-it-yourselfer". They are written to inform these technicians of conditions that may occur on some vehicles, or to provide information that could assist in the proper service of a vehicle. Properly trained technicians have the equipment, tools, safety instructions, and know-how to do a job properly and safely. If a condition is described, DO NOT assume that the bulletin applies to your vehicle, or that your vehicle will have that condition. See your GM dealer for information on whether your vehicle may benefit from the information.



WE SUPPORT  
VOLUNTARY  
TECHNICIAN  
CERTIFICATION

## COMPONENT LOCATION

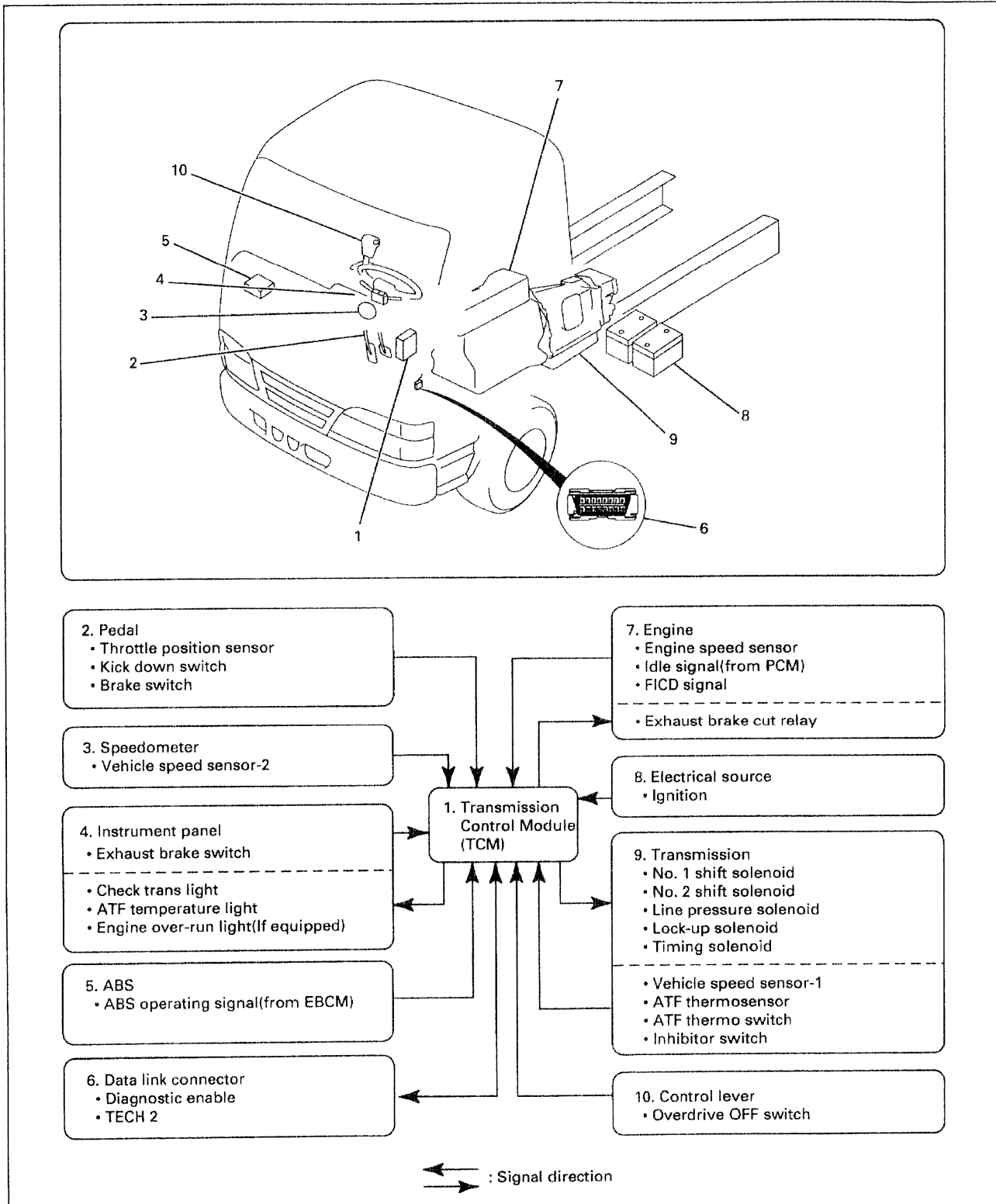
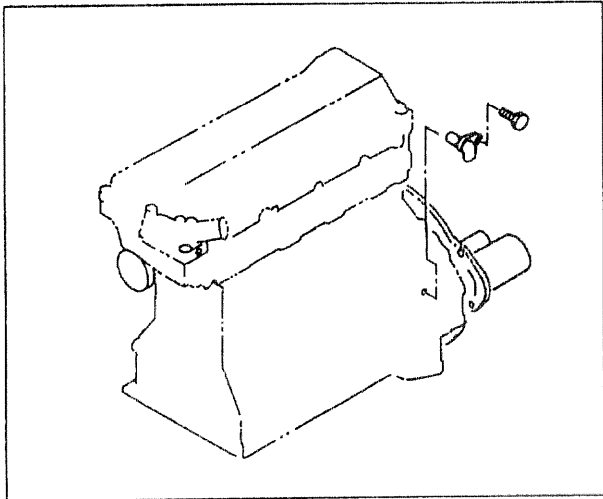

Figure 3. Component Location

## ENGINE SPEED SENSOR

**(Figure 33)**

- The engine speed sensor fitted on the timing gear case.
- It detects the speed of revolution of the injection pump drive gear and generates a pulse (AC) signal accordingly.
- The pulse signal is sent to the TCM where it is converted into the engine revolution.



**Figure 33. Engine Speed Sensor**

## TRANSMISSION CONTROL MODULE (TCM)

- The TCM is fitted under the meter cluster by means of four stud bolts. It receives signals from various sensors and judges the running condition of the vehicle accordingly. It compares the result with programmed gear shifting parameters, lock-up operating parameters, etc., and sends signals to solenoids and controls them accordingly.
- It controls seven different items:

1. Line pressure
2. Gear shifting (including overdrive control)
3. Lock-up
4. Exhaust brake
5. "2-3" timing
6. Self-diagnosis
7. Fail-safe function