

[Select Vehicle](#) | [New TSBs](#) | [Technician's Reference](#)

Component Search:

  [Conversion Calculator](#)**2006 Ford Truck F 350 2WD Super Duty V8-6.0L DSL Turbo VIN P**[Vehicle Level](#) → [Technical Service Bulletins](#) → [All Technical Service Bulletins](#) → [Cooling System - Fuel Contamination Diagnostics](#) ←**Cooling System - Fuel Contamination Diagnostics**

TSB 08-23-8

11/24/08

6.0L DIESEL FUEL IN ENGINE COOLANT DIAGNOSTICS**FORD:**2003-2005 Excursion
2003-2007 F-Super Duty
2004-2008 E-Series**ISSUE**

Some 2003-2005 Excursion, 2003-2007 F-Super Duty and 2004-2008 E-Series vehicles equipped with a 6.0L engine may exhibit fuel in the engine coolant, due to leaks in the cylinder head fuel injector area. Symptoms may include fuel in engine coolant and coolant expulsion from the degas bottle.

ACTION

Follow the Service Procedure steps to correct the condition.

SERVICE PROCEDURE

Inspect the degas bottle for evidence of fuel in engine coolant. If diesel fuel is present, refer to the following Service Procedure. If not, follow normal diagnostics.

NOTE IT IS VERY IMPORTANT TO ENSURE A COMPLETE FLUSHING OF THE ENGINE [COOLING SYSTEM](#) IS PERFORMED TO REMOVE ALL CONTAMINANTS FOLLOWING REPAIR.

1. Drain coolant from [cooling system](#).
2. Remove all injectors from both cylinder heads. Refer to Workshop Manual (WSM), Section 313-04C.
3. Wipe injector bore clean of oil and fuel then apply a thin layer of bubbly type liquid hand soap, dish soap or laundry soap inside each injector bore. Ensure injector sleeve lip and cylinder head casting are coated with a soap layer. (Adding a small amount of water to the soap aids in creating bubbles)

4. Fit the [cooling system](#) pressure tester, refer to WSM, Section 303-03. (Do not add coolant)
5. Apply 5-10 psi (34-69 kPa) of air pressure to sealed [cooling system](#). It is suggested to use a hand operated pressure tester or regulated shop air with tee in degas hose to degas bottle.

NOTE MORE THAN 10 PSI (69 kPa) AIR PRESSURE CAN PUSH THE SOAP FROM THE LEAK POINT AND NO BUBBLES WILL BE PRESENT OR CREATED, MAKING DIAGNOSIS DIFFICULT.

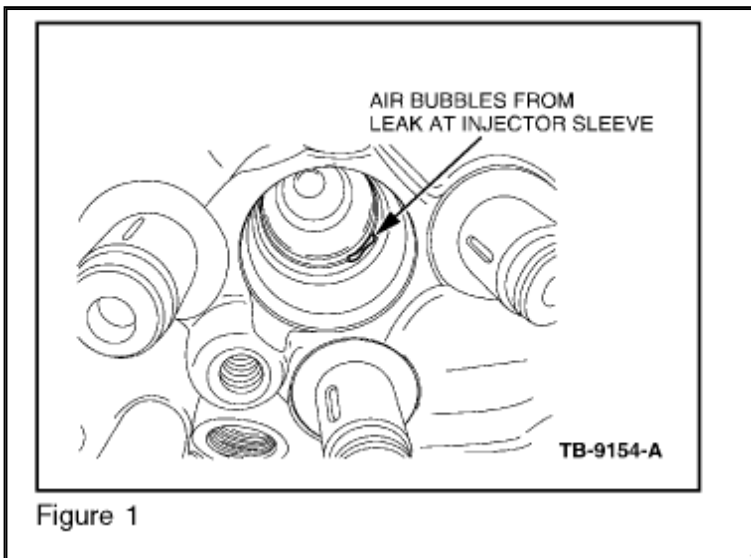

Zoom

Sized for Print

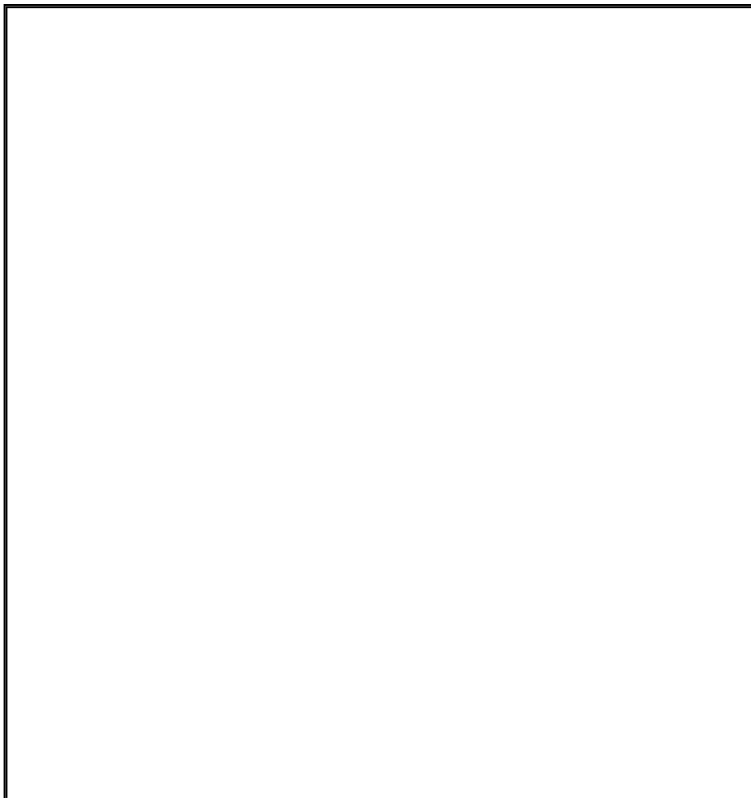

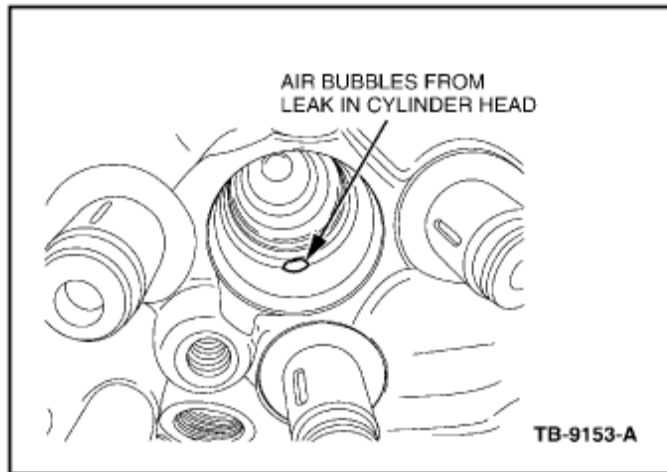

Figure 2

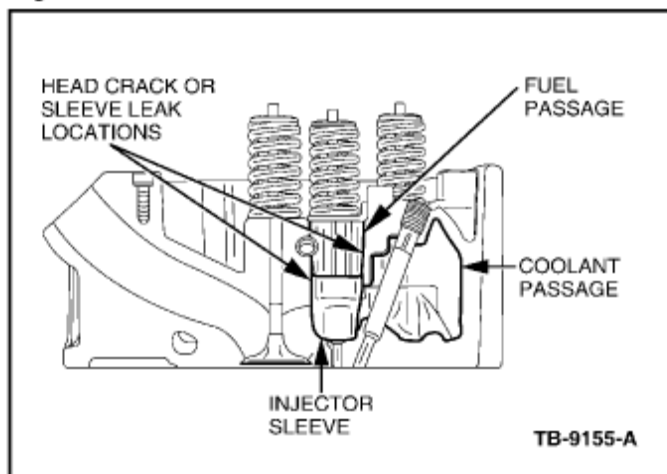

Figure 3

Zoom

Sized for Print

6. Inspect each injector bore for bubbles. (A light and mirror or bore-scope may aid in pinpointing a leak location.) If bubbles are observed, determine if bubbles originate from the injector sleeve lip (Figure 1) or cylinder head casting. (Figure 2) Refer to cutaway view of the cylinder head. (Figure 3)
 - a. Replace the injector sleeve if found to be leaking at sleeve lip, refer to WSM 303-04C.
 - b. Replace cylinder head if leaking through casting, refer to WSM 303-01C.
 - c. Flush [cooling system](#), refer to another applicable Technical Service Bulletin (TSB) for proper cooling system flush procedures.

OTHER APPLICABLE ARTICLES: 08-23-01

WARRANTY STATUS: Eligible Under Provisions Of New Vehicle Limited Warranty Coverage

IMPORTANT : Warranty coverage limits/policies are not altered by a TSB.

Warranty coverage limits are determined by the identified causal part.

OPERATION	DESCRIPTION	TIME
MT082308	Use SLIS Operations If Available; Claim Additional Diagnosis Or Labor Performed As Actual Time	Actual Time

DEALER CODING

BASIC PART NO.	CONDITION CODE
6049	01

NOTE: The information in Technical Service Bulletins is intended for use by trained, professional technicians with the knowledge, tools, and equipment to do the job properly and safely. It informs these technicians of conditions that may occur on some vehicles, or provides information that could assist in proper vehicle service. The procedures should not be performed by "do-it-yourselfers". Do not assume that a condition described affects your car or truck. Contact a Ford, Lincoln, or Mercury dealership to determine whether the Bulletin applies to your vehicle.

Zoom

Sized for Print

Disclaimer