

9/29/2010 5:39:38 AM

ALLDATA

Library Research Services
Direct Fax: 800-684-4241

Send Via: EMAIL

Feedback ID: 1382340
Additional Request: N
Action: MISSING
Product: PRO Active

To: DAN GRIMWOOD
ATTN: DAN GRIMWOOD
Email: jettadan@yahoo.com

Fax #:
Bus: 812-589-9557
CSR: gpangle

Pages: 9 LRS: tp

Year	Make	Model	Engine	Trans
2003	Hyundai	Accent	L4-1.6L	A

TOC Zone: 22 - Engine

Component/Path: Cylinder Head Assembly
Valve Seat

Info Type: 28 - Specifications

Additional Info:

Problem: need valve stem height from bottom of head to top of valve stem.

Notes only spring height offered oe valve seat article.no other specs

If the data received does not meet your needs, call 866-537-1571

Thank You for choosing ALLDATA

ACCENT(LC) >2003 > G 1.6 DOHC > Engine Mechanical System > Cylinder Head
 Assembly > Valve > Repair procedures

DISASSEMBLY

- Using a tool remove the cylinder head bolts in the order shown in the illustration.

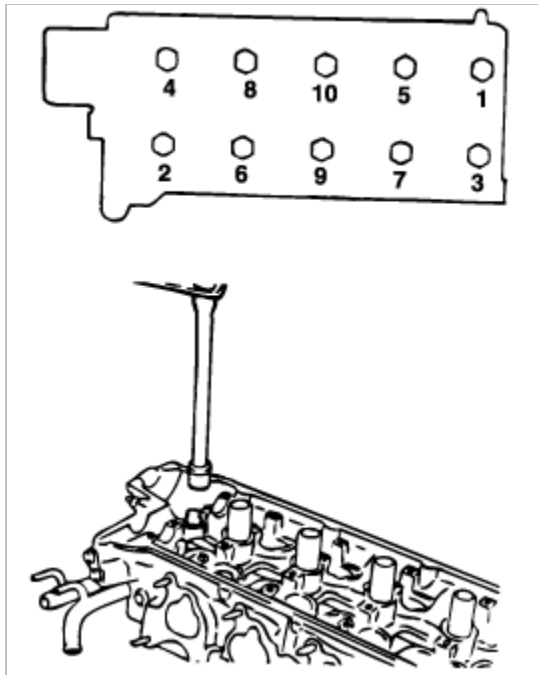

- Using the special tool (09222-28000, 09222-28100), remove the valve retainer lock. Next remove the spring retainer, valve spring, spring seat and valve.

NOTE

Arrange these parts so that they can be reinstalled in their original positions.

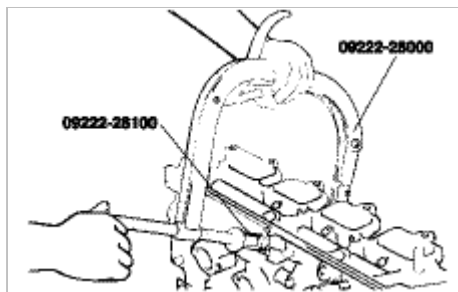

- Remove the valve stem seals with pliers.

NOTE

Do not reuse the valve stem seals.

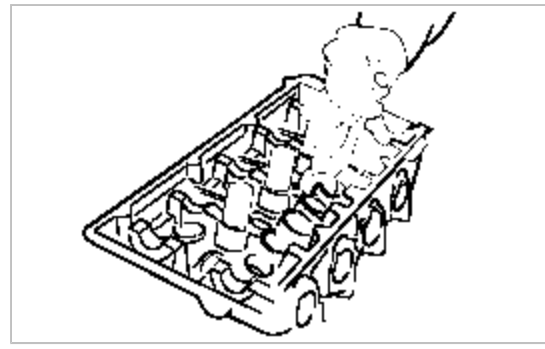

INSPECTION

CYLINDER HEAD

1. Check the cylinder head for cracks, damage and coolant leakage. If cracked, replace the cylinder head.
2. Remove scale, sealing compound and carbon deposits completely. After cleaning the oil passages, apply compressed air to verify that the passages are not clogged.

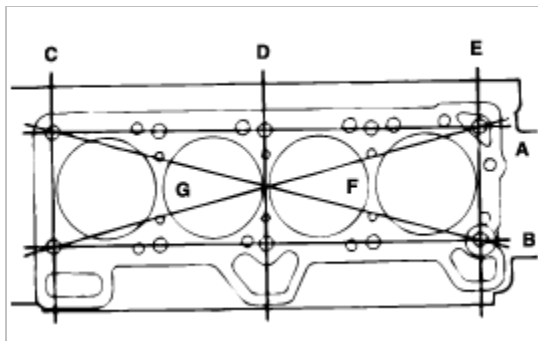

3. Check the cylinder head surface for flatness in the direction as shown in the illustration. If flatness exceeds the service limit in any direction, either replace the cylinder head or machine the cylinder head matching surface lightly.

Flatness of cylinder head gasket surface
 Standard : Less than 0.03 mm (0.0012 in.)
 Limit : 0.2 mm (0.008 in.)

VALVES

1. Using a wire brush, clean the valve thoroughly.

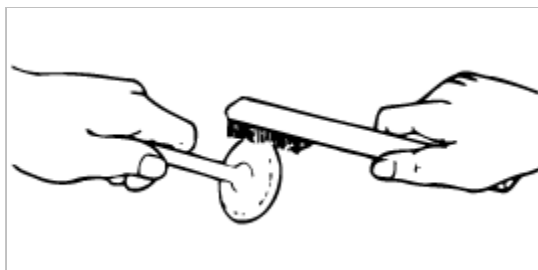

2. Check each valve for wear, damage and distortion of the head and the stem at B position. Replace, if necessary. If stem end, A, is hollowed out or worn, resurface as necessary. This correction must be limited to a minimum. Also resurface the valve face. Replace the valve if the margin has decreased to less than the service limit.

Margin

[Standard]

Intake : 1.1 mm (0.043 in.)

Exhaust : 1.3 mm (0.051 in.)

[Limit]

Intake : 0.8 mm (0.028 in.)

Exhaust : 1.0 mm (0.040 in.)

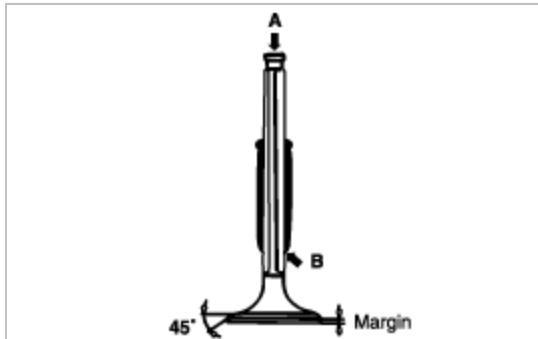
**VALVE SPRINGS**

1. Check the free height of each valve spring. If they exceed the service limit, replace the springs.
 2. Using a square, test the squareness of each spring. If a spring is excessively out - of - square, replace it.
-

Valve spring

[Standard]

Free height : 44 mm (1.7323 in.)

Load :

21.6 kg/35 mm (47.6 lb/1.3780 in.)

45.1 kg/27.2 mm (99.4 lb/1.0709 in.)

Out of square : 1.5° or less 100

[Limit]

Free height : - 1.0 mm (- 0.039 in.)

Out of square : 4°

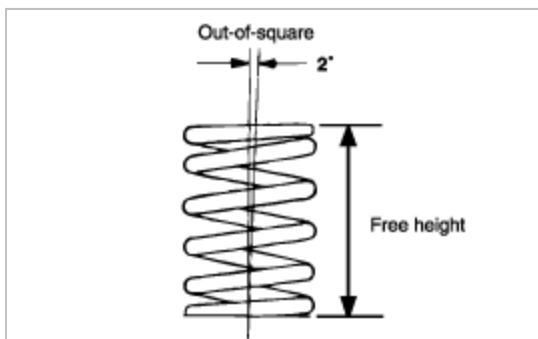

Check the valve stem-to-guide clearance. If the clearance exceeds the service limit, replace the valve guide with the next oversize part.

Valve stem-to-clearance

[Standard]

Intake : 0.03 ~ 0.06 mm (0.0012 ~ 0.0024 in.)

Exhaust : 0.05 ~ 0.08 mm (0.0020 ~ 0.0031 in.)

[Limit]

Intake : 0.1 mm (0.0040 in.)

Exhaust : 0.15 mm (0.0059 in.)

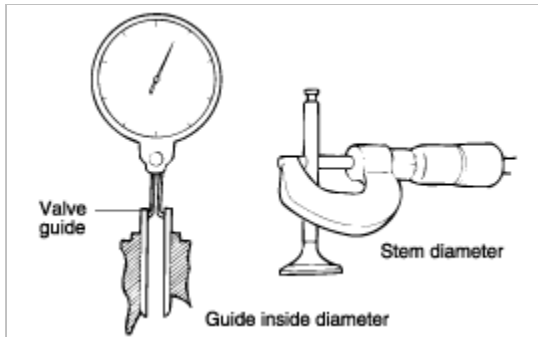

RECONDITIONING VALVE SEAT

Check the valve seat for overheating and unequal contact with the valve face. Recondition or replace the seat if necessary. Before reconditioning the seat, check the valve guide for wear. If the valve guide is worn, replace it and then recondition the seat. Recondition the valve seat with a valve seat grinder or cutter. The valve seat contact width should be within specifications and centered on the valve face. After reconditioning, the valve and valve seat should be lapped lightly with a lapping compound.

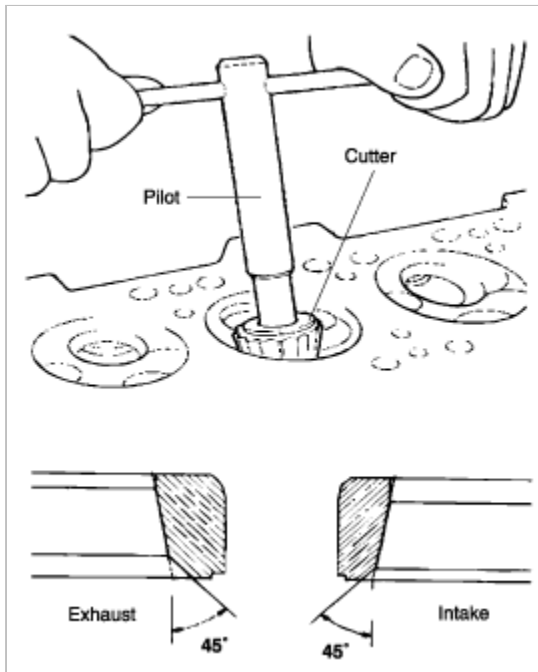

REPLACING THE VALVE SEAT RING

1. Cut away the inner face of the valve seat to reduce the wall thickness.

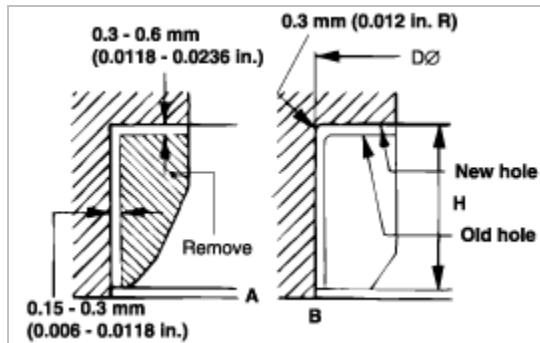

2. Enlarge the diameter of the valve seat so that it matches the specified oversize hole diameter of the new valve seat ring.
3. Heat the cylinder head to about 250°C (480°F) and press - fit an oversize seat ring for the bore in the cylinder head.
4. Using lapping compound, lap the valve to the new seat.

Valve seat contact width

Intake : 0.8 ~ 1.2 mm (0.0315 ~ 0.0472 in.)

Exhaust : 1.3 ~ 1.7 mm (0.0512 ~ 0.0670 in.)

VALVE SEAT INSERT OVSIZES

Description	Size mm (in.)	Size mark	Seat ring height H mm (in.)	Oversize hole diameter I.D. mm (in.)
Intake valve Seat ring	0.3 (0.012) O.S.	30	5.1~5.3(0.2008~0.2087)	30.7~30.721 (1.2087~1.2095)
	0.6 (0.024) O.S.	60	5.4~5.6(0.2126~0.2205)	31.0~31.021(1.2205~1.2213)
Exhaust valve Seat ring	0.3 (0.012) O.S.	30	6.2~6.4(0.2441~0.2520)	27.3~27.321(1.0748~1.0756)
	0.6 (0.024) O.S.	60	6.5~6.7(0.2560~0.2638)	27.6~27.621(1.0866~1.0874)

REPLACING VALVE GUIDE

1. Using the special tool (09221~22000 A/B), withdraw the old valve guide toward the bottom of cylinder head.
2. Recondition the valve guide hole so that it can match the newly press-fitted oversize valve guide.

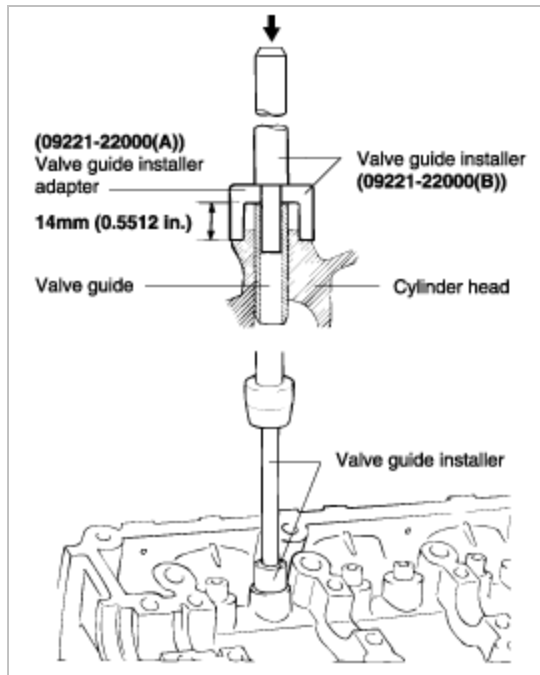

3. Using the special tool (09221 ~ 22000 A/B), press-fit the valve guide. The valve guide must be press-fitted from the upper side of the cylinder head.
4. After the valve guide is press-fitted, insert a new valve and check for proper the clearance
5. After the valve guide is replaced, check that the valve is seated properly. Recondition the valve seats as necessary.

VALVE GUIDE OVERSIZES

Over size mm (in.)	Size mark	Oversize valve guide hole size mm (in.)
0.05 (0.002)	5	11.05~11.068 (0.4350~0.4357)
0.25 (0.010)	25	11.25~11.268 (0.4429~0.4436)
0.50 (0.020)	50	11.50~11.518 (0.4528~0.4535)

REASSEMBLY

NOTE

1. Clean each part before assembly.
2. Apply engine oil to the sliding and rotating parts.

1. Install the spring seats.
Using a special tool (09222-22001), tap the seal in position lightly.

NOTE

- Do not reuse old valve stem seals.
- Incorrect installation of the seal could result in oil leakage past the valve guides.

2. Apply engine oil to each valve. Insert the valve into the valve guide.
Avoid pushing the valve into the seal by force. After inserting the valve, check that it moves smoothly.

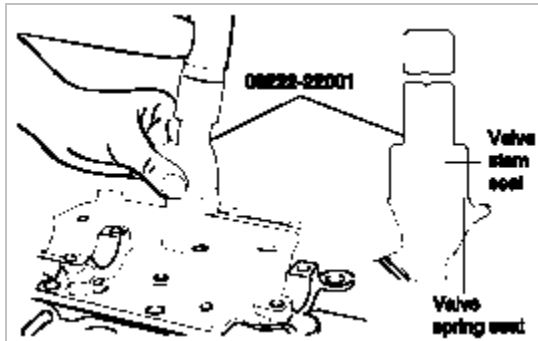

3. Place valve springs so that the side coated with enamel faces toward the valve spring retainer and then install the retainer.

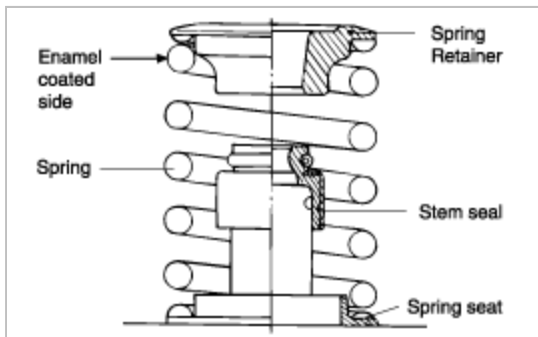

4. Using the special tool (09222-28000, 09222-28100), compress the spring and install the retainer locks. After installing the valves, ensure that the retainer locks are correctly in place before releasing the valve spring compressor.

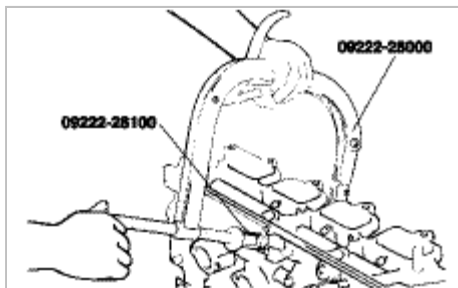

NOTE

When the spring is compressed, Check that the valve stem seal is not pressed against the bottom of the retainer.

5. Clean both gasket surfaces of the cylinder block and cylinder head.
6. Verify the identification marks on the cylinder head gasket.
7. Install the gasket so that the surface with the identification mark faces toward the cylinder head.
8. Tighten the bolts to the specified torque in the sequence shown.

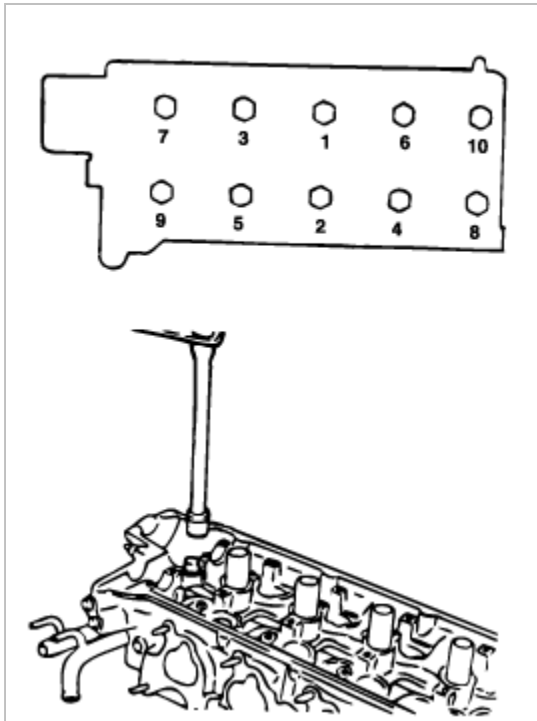

Cylinder head bolt :

30 Nm (300 kg.cm, 22 lb.ft)+90°+Release all bolts + 30 Nm(300kg.cm, 22 lb.ft)+90°
