

1993 Mazda 626 L4-1991cc 2.0L DOHC

Vehicle Level → Cruise Control → Testing and Inspection → Component Diagnosis & Testing ←

### Component Diagnosis & Testing

1. Turn ignition switch and cruise control main switch to On position.
2. Ensure main switch indicator lamp illuminates. If lamp does not illuminate, check continuity between terminals of cruise control main switch, **Fig. 16 through 19** . If switch operates correctly, repair wire harness.

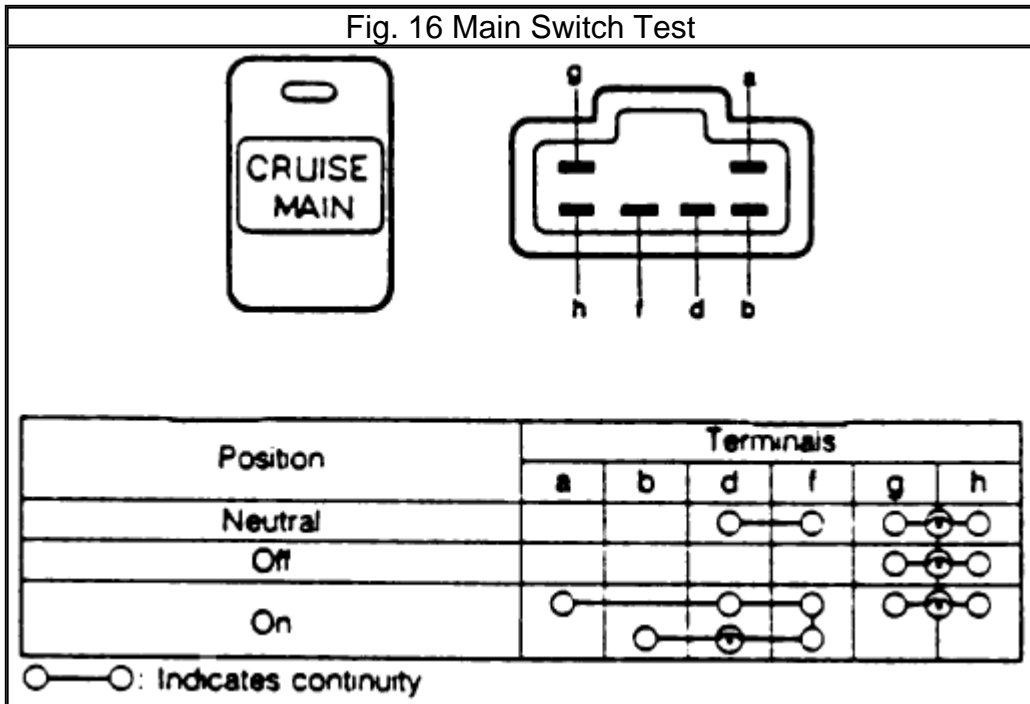

Zoom

Sized for Print

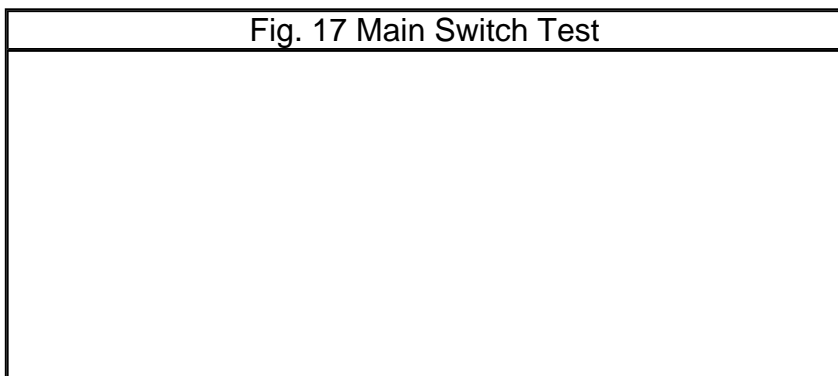

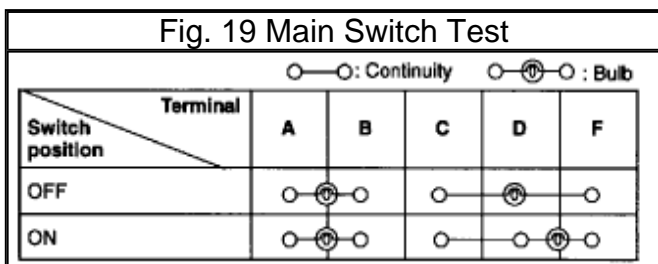
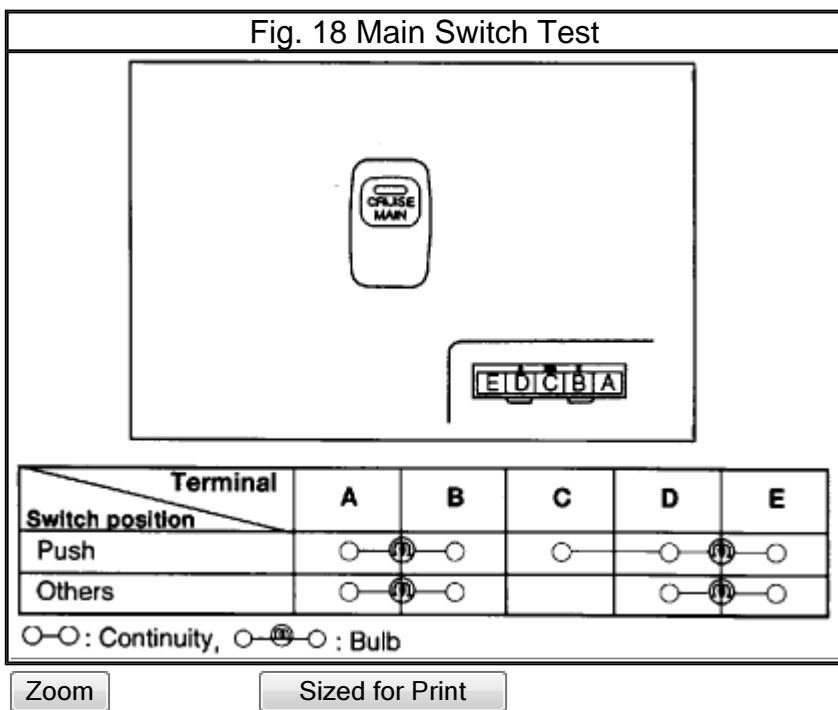
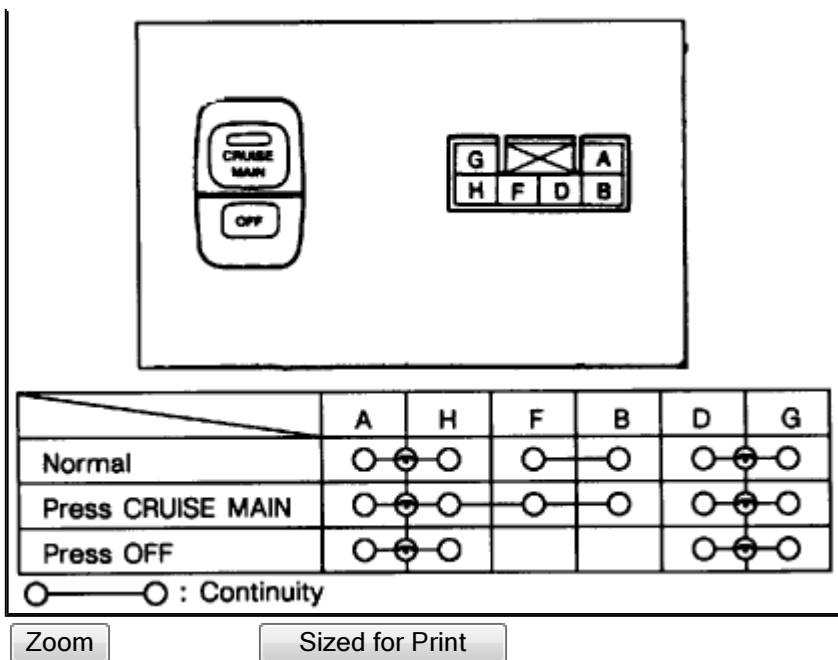

Zoom

Sized for Print

- Measure voltage at following terminals of the control unit, **Fig. 20 through 25** . If terminal voltage are correct, replace cruise control unit.

**Fig. 20 Cruise Control Unit Voltage Test**

**V<sub>b</sub>: Battery voltage**

Terminal	Wire color	Connected to	Test condition	Specification
a	(L/Y)	Actuator	Main switch off	0V
			Main switch on	9V
b	(G/Y)	Actuator	Main switch off	0V
			Main switch on	9V
c	(G)	Actuator	Main switch off	0V
			Main switch on	9V
e	(L/B)	Main switch	Main switch off	V <sub>b</sub>
			Main switch on	0V
f	(L/O)	Main switch	Main switch off	0V
			Main switch on	V <sub>b</sub>
g	(R)	ECAT control unit	Ignition switch OFF	0V
			Ignition switch ON	V <sub>b</sub>
h	(O)	Stoplight switch (For cruise)	Brake pedal depressed	0V
			Brake pedal released	9V
i	(B/Y)	Clutch switch	Clutch pedal depressed	0V
			Clutch pedal released	5V
		Inhibitor switch	Shift to "N" or "P" range	0V
			Shift to other range	5V
l	(L/R)	Cruise control switch (Set/Coast switch)	Main switch ON	V <sub>b</sub>
			While turning set switch Main switch ON	0V
m	(W/G)	Stoplight switch	Brake pedal depressed	V <sub>b</sub>
			Brake pedal released	0V
n	(L)	Cruise control switch (Resume/Accel switch)	Main switch ON	V <sub>b</sub>
			While turning resume switch Main switch ON	0V
o	(L/W)	Actuator	Main switch OFF	0V
			Main switch ON	9V
p	(G/R)	Speed sensor	While rotating rear tires	Cycles 0-5V
s	(G/W)	Battery	Constant	V <sub>b</sub>
t	(B)	Ground	Constant	0V

Zoom

Sized for Print

Fig. 21 Cruise Control Unit Voltage Test

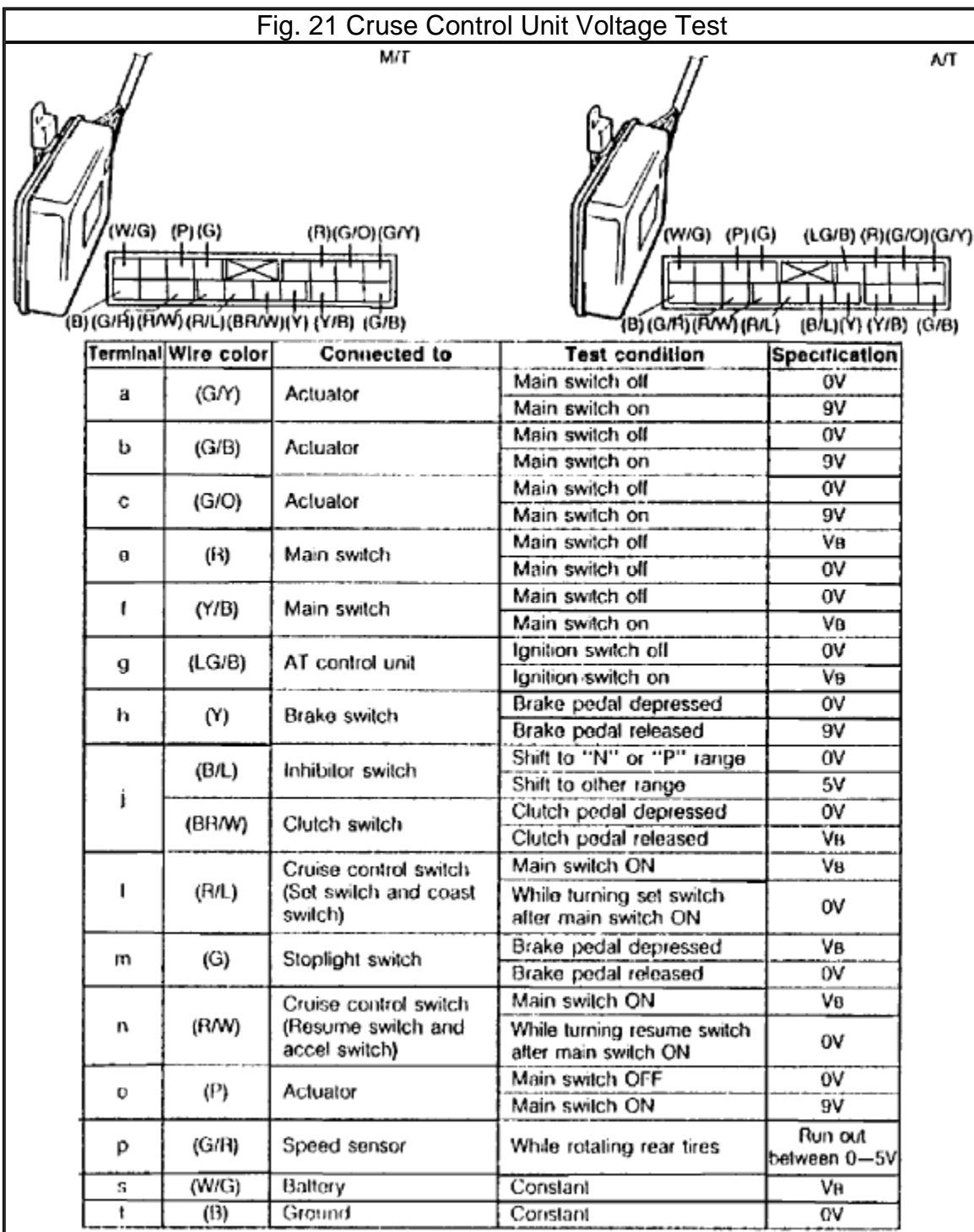

Zoom

Sized for Print

Fig. 22 Cruise Control Unit Voltage Test (Part 1 Of 2)

B+: Battery positive voltage



Terminal	Signal	Connection	Test condition		Voltage	Inspection area		
A	Cruise actuator on signal	Cruise actuator (vent 1)	Ignition switch at ON	Cruise control main switch on	9 V	<ul style="list-style-type: none"> <li>METER 15 A fuse</li> <li>Cruise control main switch</li> <li>Cruise actuator</li> </ul>		
				Other	0 V			
B	Cruise actuator on signal	Cruise actuator (vac)	Ignition switch at ON	Cruise control main switch on	9 V	<ul style="list-style-type: none"> <li>METER 15 A fuse</li> <li>Cruise control main switch</li> <li>Brake switch</li> <li>Cruise actuator</li> </ul>		
				Other	0 V			
C	Cruise actuator on signal	Cruise actuator (vent 2)	Ignition switch at ON	Cruise control main switch on	9 V	<ul style="list-style-type: none"> <li>METER 15 A fuse</li> <li>Cruise control main switch</li> <li>Brake switch</li> <li>Cruise actuator</li> </ul>		
				Other	0 V			
E	Cruise control main switch on/off signal	Cruise control main switch (N.C)	Ignition switch at ON	Other	B+	<ul style="list-style-type: none"> <li>METER 15 A fuse</li> <li>Cruise control main switch</li> </ul>		
				Cruise control main switch off side pushed	0 V			
F	Cruise control main switch on/off signal	Cruise control main switch (N.O)	Ignition switch at ON	Cruise control main switch off side pushed	0 V	<ul style="list-style-type: none"> <li>METER 15 A fuse</li> <li>Cruise control main switch</li> </ul>		
				Other	B+			
G	O/D off signal	TCM	Ignition switch at ON		B+	TCM		
H	Brake on signal	Brake switch	Ignition switch at ON and cruise control main switch on	Release brake pedal	9 V	<ul style="list-style-type: none"> <li>METER 15 A fuse</li> <li>Cruise control main switch</li> <li>Brake switch</li> </ul>		
				Depress brake pedal	B+			
J	AT	Selector lever position signal	Transmission range switch	Ignition switch at ON	N or P range	0 V	Transmission range switch	
					Other	B+		
	MT	Clutch switch on signal	Clutch switch	Ignition switch at ON		Depress clutch pedal	0 V	Clutch switch
						Other	B+	

Zoom

Sized for Print

Fig. 22 Cruise Control Unit Voltage Test (Part 2 Of 2)

**Cont'd** B+: Battery positive voltage

Terminal	Signal	Connection	Test condition		Voltage/ Continuity	Inspection area
L	Cruise control switch on signal	Cruise control switch	Ignition switch at ON and cruise control main switch on	SET/COAST switch pushed	0 V	<ul style="list-style-type: none"> <li>METER 15 A fuse</li> <li>Cruise control main switch</li> <li>Clock spring</li> <li>Cruise control switch</li> </ul>
M	Brake on signal	Brake switch	Depress brake pedal		B+	<ul style="list-style-type: none"> <li>STOP 15 A fuse</li> <li>Brake switch</li> </ul>
			Other		0 V	
N	Cruise control switch on signal	Cruise control switch	Ignition switch at ON and cruise control main switch on	RESUME/ACCEL switch pushed	0 V	<ul style="list-style-type: none"> <li>METER 15 A fuse</li> <li>Cruise control main switch</li> <li>Clock spring</li> <li>Cruise control switch</li> </ul>
O	Cruise actuator on signal	Cruise actuator	Ignition switch ON and cruise control main switch on	Depress brake pedal	0 V	<ul style="list-style-type: none"> <li>METER 15 A fuse</li> <li>Cruise control main switch</li> </ul>
				Release brake pedal	9 V	
P	Vehicle speed sensor on signal	Vehicle speed sensor	Rear tires rotating		Alternates 0 V and 5 V	<ul style="list-style-type: none"> <li>Vehicle speed sensor</li> <li>Instrument cluster</li> </ul>
S	+B	STOP 20 A fuse	Constant		B+	STOP 15 A fuse
T	GND	GND	Check for continuity to ground		Yes	GND

Zoom

Sized for Print

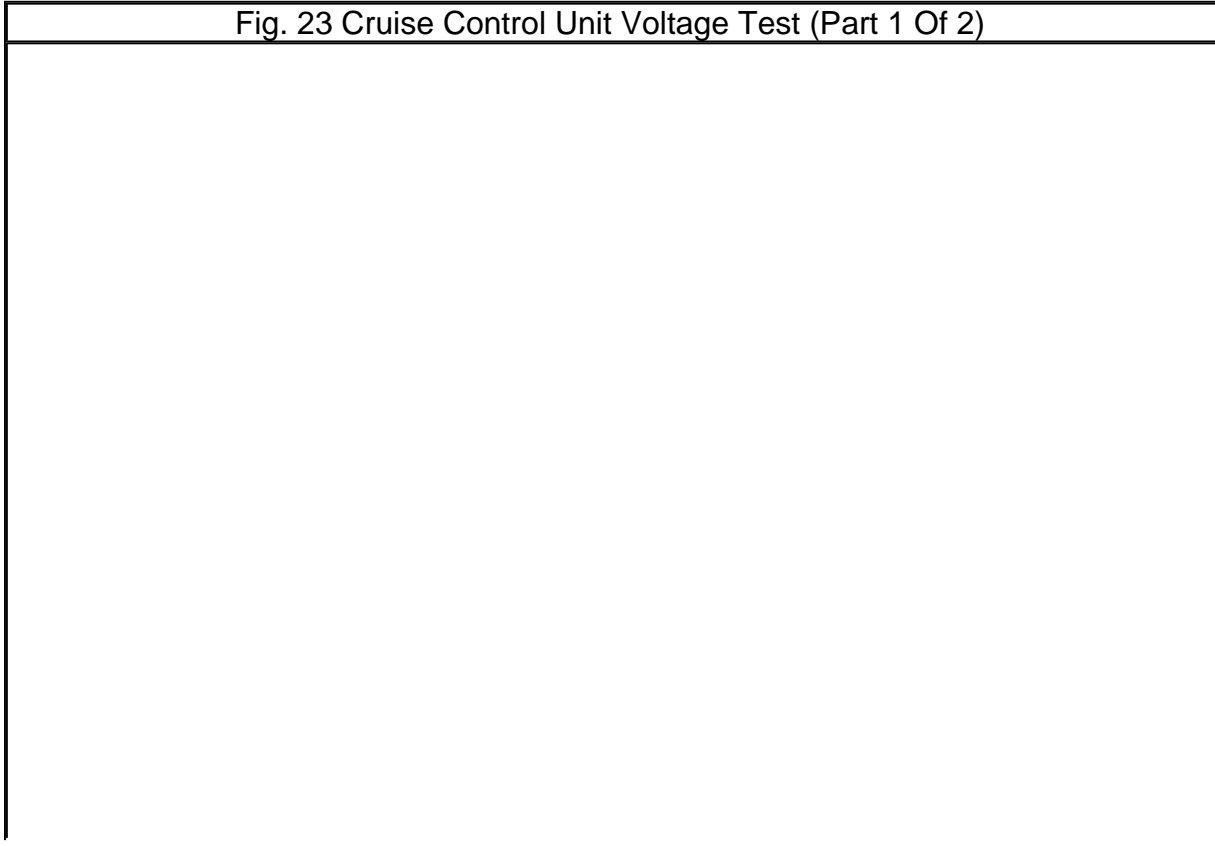

B+: Battery positive voltage



Terminal	Signal	Connection	Test condition		Voltage	Inspection area	
A	Cruise actuator on signal	Vacuum pump (control valve)	Ignition switch at ON	Cruise control main switch on	9 V	<ul style="list-style-type: none"> <li>METER 15 A fuse</li> <li>Cruise control main switch</li> <li>Vacuum pump</li> </ul>	
				Other	0 V		
B	Cruise actuator on signal	Vacuum pump (motor)	Ignition switch at ON	Cruise control main switch on	9 V	<ul style="list-style-type: none"> <li>METER 15 A fuse</li> <li>Cruise control main switch</li> <li>Brake switch</li> <li>Vacuum pump</li> </ul>	
				Other	0 V		
C	Cruise actuator on signal	Vacuum pump (release valve)	Ignition switch at On	Cruise control main switch on	9 V	<ul style="list-style-type: none"> <li>METER 15 A fuse</li> <li>Cruise control main switch</li> <li>Brake switch</li> <li>Vacuum pump</li> </ul>	
				Other	0 V		
D	IG1	Instrument cluster (cruise set indicator light) Data link connector	Ignition switch at ON		B+	<ul style="list-style-type: none"> <li>METER 15 A fuse</li> <li>Cruise set indicator light bulb</li> </ul>	
			Cruise set indicator light illuminated		0 V		
E	Cruise control main switch on/off signal	Cruise control main switch	Ignition switch at ON	Cruise control main switch off side pushed	0 V	<ul style="list-style-type: none"> <li>METER 15 A fuse</li> <li>Cruise control main switch</li> </ul>	
				Other	B+		
F	—	—	—		—	—	
G	O/D off signal	PCM (KL, FS-ATX) TCM (FS-MTX ONLY)	Ignition switch at ON		B+	PCM (KL, FS-ATX) TCM (FS-MTX ONLY)	
H	Brake on signal	Brake switch	Ignition switch at ON and cruise control main switch	Release brake pedal	9 V	<ul style="list-style-type: none"> <li>METER 15 A fuse</li> <li>Cruise control main switch</li> <li>Brake switch</li> </ul>	
				Depress brake pedal	B+		
J	ATX	Selector lever position signal	Transaxle range switch	Ignition switch at ON	N or P range	0 V	Transaxle range switch
	MTX	Clutch switch on signal			Clutch switch	Ignition switch at ON	
				Other			B+
L	—	—	—		—	—	
M	Brake on signal	Brake switch	Depress brake pedal		B+	<ul style="list-style-type: none"> <li>STOP 20 A fuse</li> <li>Brake switch</li> </ul>	
			Other		0 V		

Zoom

Sized for Print

Fig. 23 Cruise Control Unit Voltage Test (Part 2 Of 2)

**B+: Battery positive voltage**

Terminal	Signal	Connection	Test condition	Voltage	Inspection area	
N	Cruise control switch on signal	Cruise control switch	Ignition switch at ON and cruise control main switch on	5 V	<ul style="list-style-type: none"> <li>• METER 15 A fuse</li> <li>• Cruise control main switch</li> <li>• Clock spring</li> <li>• Cruise control switch</li> </ul>	
			Ignition switch at ON and cruise control main switch	SET/COAST switch pushed		2 V
				RESUME/ACCEL switch pushed		3 V
O	Brake on signal	Brake switch	Ignition switch at ON and cruise control main switch	Release brake pedal	9 V	<ul style="list-style-type: none"> <li>• METER 15 A fuse</li> <li>• Cruise control main switch</li> <li>• Brake switch</li> </ul>
				Depress brake pedal	0 V	
P	Vehicle speedometer sensor on signal	Vehicle speedometer sensor	Front tires rotating	Alternates 0 V and 5 V	<ul style="list-style-type: none"> <li>• Vehicle speedometer sensor</li> <li>• Instrument cluster</li> </ul>	
Q	TEST signal	Data link connector	—	—	—	
R	—	—	—	—	—	
S	+B	STOP 20 A fuse	Constant	B+	STOP 20 A fuse	
T	GND	GND	Check for continuity to ground	Yes	GND	

Zoom

Sized for Print

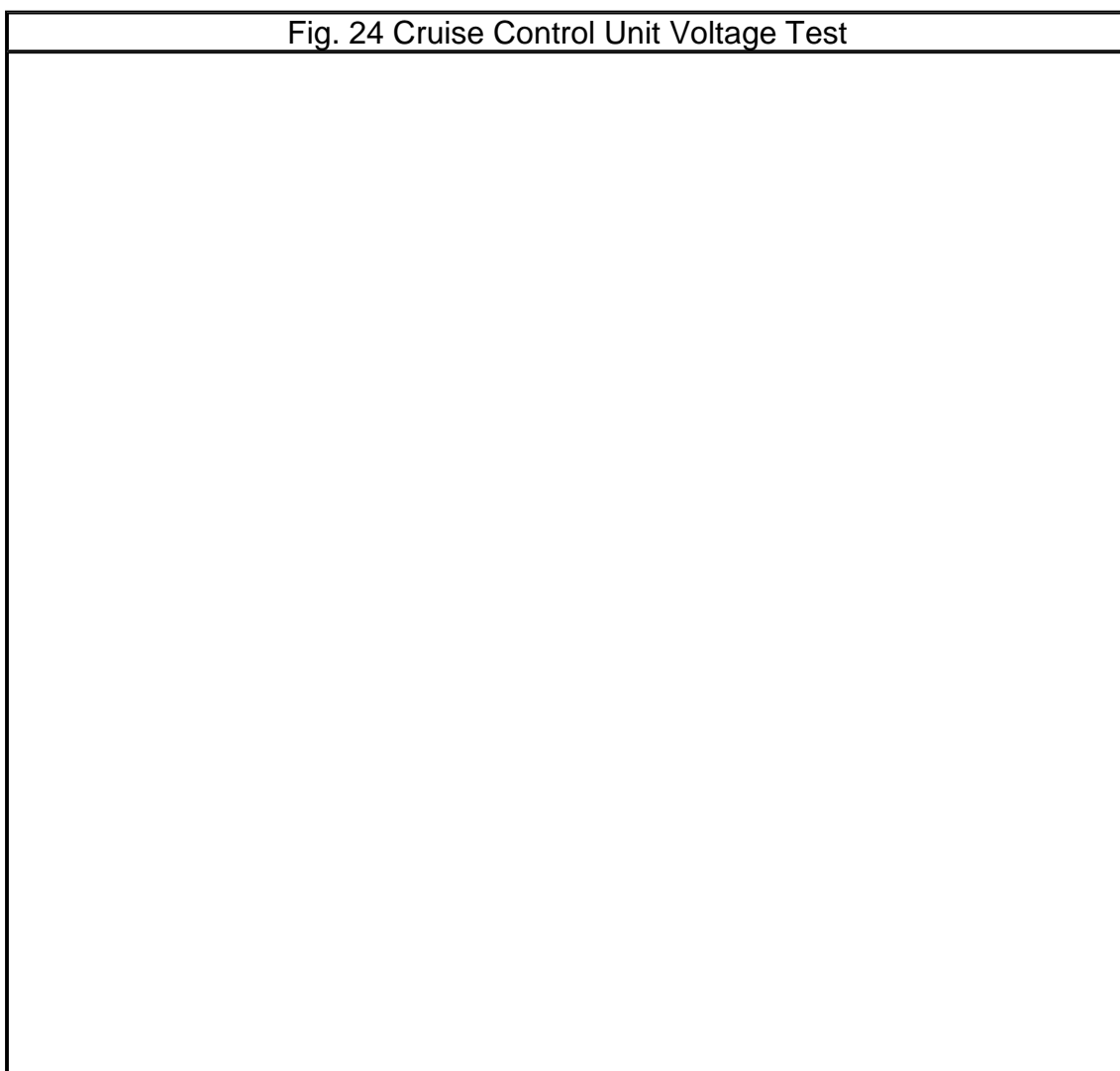
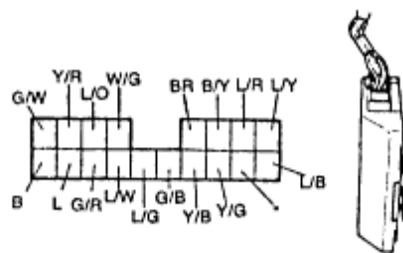

Fig. 24 Cruise Control Unit Voltage Test



V<sub>B</sub>: Battery voltage

Terminal	Connected to	Voltage	Procedure
a (Output)	Actuator	0V Approx. 9V	Ignition switch ON Main switch ON
b (Output)	Actuator	0V Approx. 9V	Ignition switch ON Main switch ON
c (Output)	Actuator	0V Approx. 9V	Ignition switch ON Main switch ON
d			
e	Ignition switch	V <sub>B</sub>	Ignition switch ON
f (Input)	Cruise control switch (Main switch)	V <sub>B</sub>	While pushing the main switch
g (Input)	EC-AT control unit (only AT)	V <sub>B</sub>	Ignition switch ON
h (Input)	Stop switch 2	Approx. 9V	Ignition switch ON and main switch ON Brake pedal depressed
j (Input) <b>Note</b> <b>Disconnect EGI control unit connector</b>	Inhibitor switch (AT)	0V Approx. 5V	"N" or "P" range and main switch ON Other range and main switch ON
	Clutch switch (MT)	0V Approx. 5V	Clutch pedal depressed and main switch ON Main switch ON
l (Input)	Cruise control switch (Set switch)	V <sub>B</sub>	Main switch ON
		0V	While pushing the set switch after main switch ON
m (Input)	Stoplight switch 1 (N.O)	0V	Ignition switch ON
		V <sub>B</sub>	Brake pedal depressed
n (Input)	Cruise control switch (Coast switch)	V <sub>B</sub>	Main switch ON
		0V	While turning the COAST position after main switch ON
o (Input)	Stoplight switch 2 (N.C)	Approx. 9V	Main switch ON
		0V	Brake pedal depressed
p (Input) <b>Note</b> <b>Disconnect EC-AT control unit connector</b>	Speed sensor	Run out between 0-5V	While rotating the rear tire
q (Output)	Main indicator	Approx. 0V	Ignition switch ON
		V <sub>B</sub>	Main switch ON
r (Input)	Cruise control switch (Resume switch)	V <sub>B</sub>	Main switch ON
		Approx. 0V	While turning the RESUME position after main switch ON
s	Battery	V <sub>B</sub>	Constant
t	Ground	0V	Constant
		V <sub>B</sub>	

Zoom

Sized for Print

Fig. 25 Cruise Control Unit Voltage Test (Part 1 Of 2)

B+: Battery positive voltage

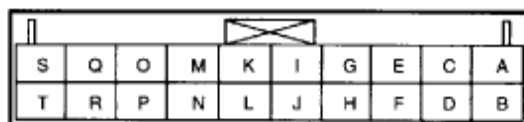

Terminal	Signal	Connection	Test condition		Voltage	Inspection area
A	Cruise actuator on	Cruise actuator (vent 1)	Ignition switch at ON	Cruise control main switch on	9 V	<ul style="list-style-type: none"> <li>METER 10 A fuse</li> <li>Cruise control main switch</li> <li>Cruise actuator</li> </ul>
				Other	0 V	
B	Cruise actuator on	Cruise actuator (vac)	Ignition switch at ON	Cruise control main switch on	9 V	<ul style="list-style-type: none"> <li>METER 10 A fuse</li> <li>Cruise control main switch</li> <li>Brake switch</li> <li>Cruise actuator</li> </ul>
				Other	0 V	
C	Cruise actuator on	Cruise actuator (vent 2)	Ignition switch at ON	Cruise control main switch on	9 V	<ul style="list-style-type: none"> <li>METER 10 A fuse</li> <li>Cruise control main switch</li> <li>Brake switch</li> <li>Cruise actuator</li> </ul>
				Other	0 V	
D	IG1	Instrument cluster (cruise set indicator light)	Ignition switch at ON		B+	<ul style="list-style-type: none"> <li>METER 10 A fuse</li> <li>Cruise set indicator light bulb</li> </ul>
			Cruise set indicator light illuminated		0 V	
E	Cruise control main switch on/off	Cruise control main switch	Ignition switch at ON	Cruise control main switch off	0 V	<ul style="list-style-type: none"> <li>METER 10 A fuse</li> <li>Cruise control main switch</li> </ul>
				Cruise control main switch on	B+	
F	—	—	—		—	—
G	O/D off	ECM	Ignition switch at ON		B+	ECM
H	Brake on	Brake switch	Ignition switch at ON and cruise control main switch on		B+	<ul style="list-style-type: none"> <li>METER 10 A fuse</li> <li>Cruise control main switch</li> </ul>
I	TEST	Data link connector	—		—	—
J	Selector lever position	Transmission range switch	Ignition switch at ON	N or P range	0 V	Transmission range switch
				Other	B+	
K	—	—	—		—	—
L	—	—	—		—	—
M	Brake on	Brake switch	Depress brake pedal		B+	<ul style="list-style-type: none"> <li>STOP 15 A fuse</li> <li>Brake switch</li> </ul>
			Other		0 V	

Zoom

Sized for Print

Fig. 25 Cruise Control Unit Voltage Test (Part 2 Of 2)

**Cont'd** B+: Battery positive voltage

Terminal	Signal	Connection	Test condition	Voltage/ Continuity	Inspection area	
N	Cruise control switch on	Cruise control switch	Ignition switch at ON and cruise control main switch on	5 V	<ul style="list-style-type: none"> <li>METER 10 A fuse</li> <li>Cruise control main switch</li> <li>Clock spring</li> <li>Cruise control switch</li> </ul>	
			Ignition switch at ON and cruise control main switch on	SET/COAST switch pushed		1.5 V
				RESUME/ACCEL switch pushed		3.1 V
O	Brake on	Brake switch	Ignition switch at ON and cruise control main switch on	Release brake pedal	B+	<ul style="list-style-type: none"> <li>METER 10 A fuse</li> <li>Cruise control main switch</li> <li>Brake switch</li> </ul>
				Depress brake pedal	0 V	
P	Vehicle speed sensor on	Vehicle speed sensor	Rear tires rotating	Alternates 0 V and 5 V	<ul style="list-style-type: none"> <li>Vehicle speed sensor</li> <li>Instrument cluster</li> </ul>	
Q	—	—	—	—	—	
R	—	—	—	—	—	
S	—	—	—	—	—	
T	GND	GND	Check for continuity to ground	Yes	GND	

Zoom

Sized for Print

4. Disconnect cruise stop lamp and clutch switches and ensure continuity exists between terminals only with pedal depressed.
5. If switches operate correctly, repair wiring to switches.
6. Check for continuity between terminals of [cruise control switch](#), **Fig. 26 through 29** . If switch operates correctly, repair wire harness.

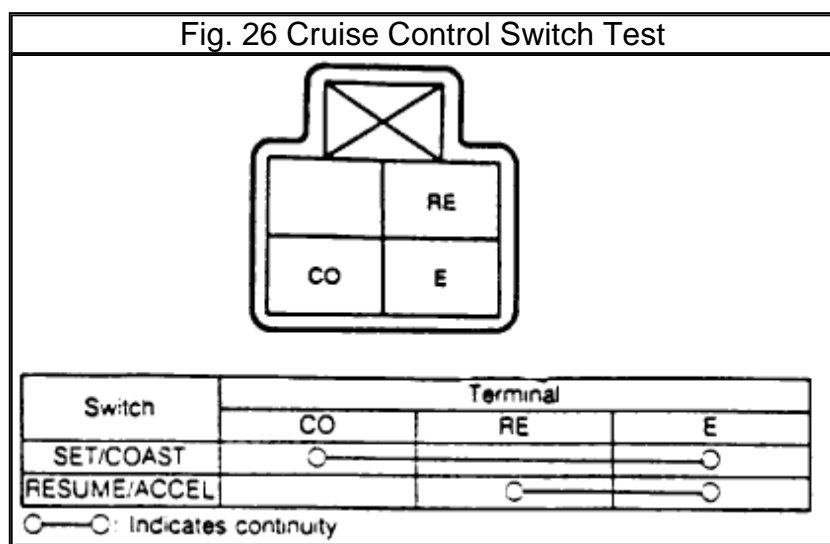

Zoom

Sized for Print

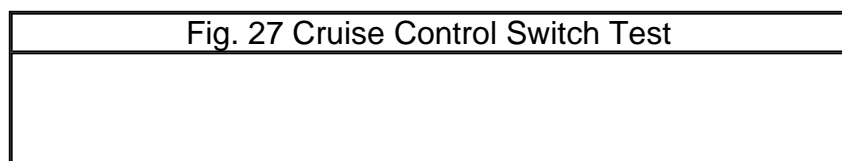

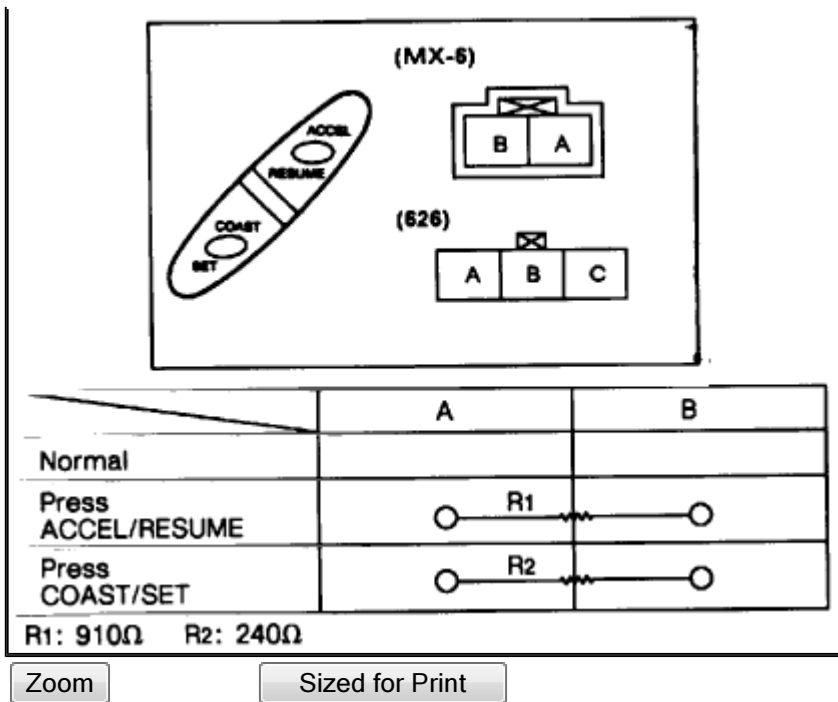

Zoom

Sized for Print

Fig. 28 Cruise Control Switch Test

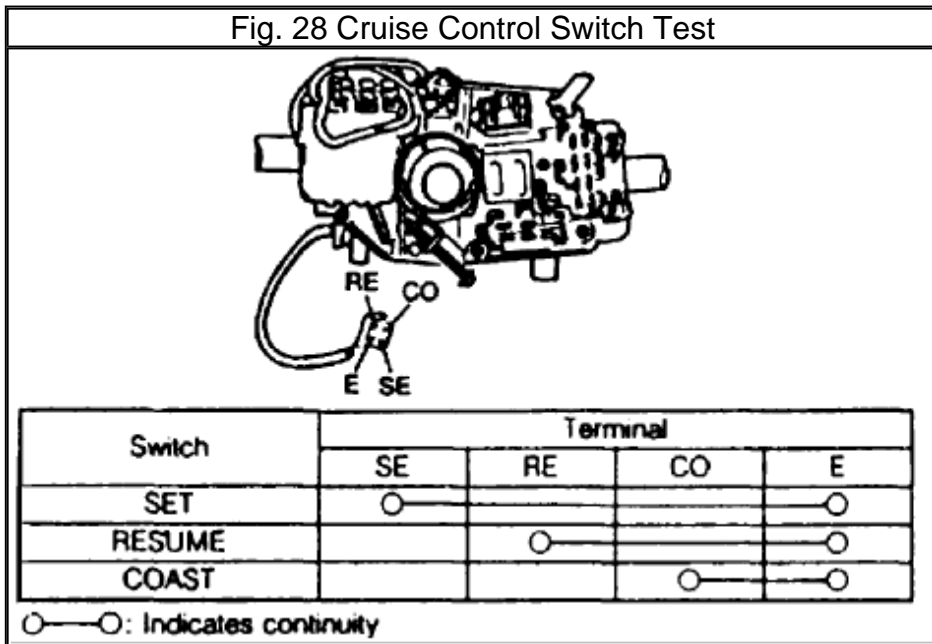

Zoom

Sized for Print

Fig. 29 Cruise Control Switch Test

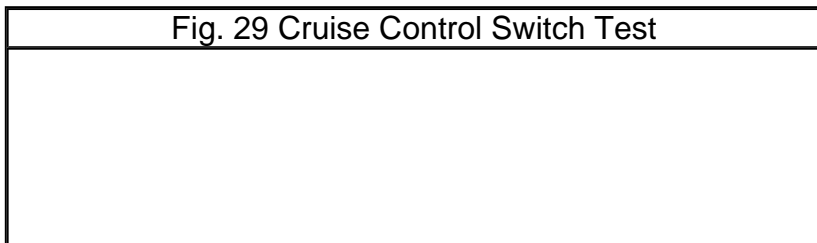

○—○ : Resistance

Terminal	A	D
SET/COAST	○—○	○ 240 Ω
RES/ACCEL	○—○	○ 910 Ω

Zoom

Sized for Print

7. Disconnect stop lamp switch and ensure continuity exists between terminals only with pedal released.
8. Measure actuator solenoid resistance using an ohmmeter, **Fig. 30 through 33** . If continuity is not as specified, replace actuator.

**Fig. 30 Actuator Operational Test**

Order	Terminal condition				Operation of control cable
	a	b	c	d	
1	Ground	Ground	Power	Ground	Pull
2	Ground	—	Power	Ground	Hold
3	Ground	—	Power	—	Extend
4	—	—	—	—	Release

Zoom

Sized for Print

**Fig. 31 Actuator Operational Test**

B+: Battery positive voltage

Connection				Actuator cable operation
A	B	C	D	
GND	GND	B+	GND	Pull
GND	—	B+	GND	Hold
GND	—	B+	—	Extend
—	—	—	—	Release

Zoom

Sized for Print

**Fig. 32 Actuator Operational Test**

Terminals	Resistance
B—A	55Ω
B—C	21Ω
B—D	55Ω

Zoom

Sized for Print

Fig. 33 Actuator Operational Test

Terminal		Resistance (Ω)
FS-ATX	Other	
A-C	B-A	55
—	B-C	21
A-B	B-D	55
B-C	—	110
D-B	—	60
D-C	—	60
A-D	—	6

Zoom

Sized for Print

9. If continuity is as specified, disconnect actuator cable, start engine and run at a idle.
10. Apply battery voltage to terminals shown in **Fig. 34 through 36** , and check actuator operation. If not as specified, replace actuator.

Fig. 34 Actuator Continuity Test



Check terminals	Resistance (Ω)	
	B2200	B2600i
c-a	60	55
c-b	23	23
c-d	60	30

Zoom

Sized for Print

Fig. 35 Actuator Continuity Test



Check terminals	Resistance
c - a	Approx. 25 to 55Ω
c - b	
c - d	

Zoom

Sized for Print

Fig. 36 Actuator Continuity Test

Order	Terminal condition				Operation of control cable
	A	A	A	A	
1	0V	B+	0V	0V	Pull
2	0V	B+	—	0V	Hold
3	—	B+	—	0V	Extend
4	—	—	—	—	Release

Zoom

Sized for Print

11. Remove instrument cluster as described in appropriate chassis section.
12. Connect an ohmmeter between the following terminals on the 12-pin connector:
  - a. **On Miata models**, connect between terminals 2F and 2D.
  - b. **On 1993-95 MPV models**, connect between terminals 1J and 2A.
13. Ensure intermittent continuity between terminals while rotating speedometer cable shaft. If four times per rotation, replace speedometer.

© 2010 ALLDATA LLC. All rights reserved.

[Terms of Use](#)