

#06-06-04-046: Information on Engine Misfire MIL/SES Light Illuminated or Flashing DTC P0300, P0301, P0302, P0303, P0304, P0305, P0306, P0307, P0308, P0420 or P0430 - (Sep 12, 2006)

Subject: Information on Engine Misfire MIL/SES Light Illuminated or Flashing DTC P0300, P0301, P0302, P0303, P0304, P0305, P0306, P0307, P0308, P0420 or P0430



Models: 1999-2007 Cadillac, Chevrolet, GMC Full-Size Pickup and/or Utility Trucks
with 4.8L, 5.3L, 5.7L, 6.0L or 6.2L VORTEC GEN III, GEN IV, V-8 Engine (VINs V, C, T, Z, B, 3, M, O, J, R, U, N, Y, K, 8 -- RPOs LR4, LY2, LM7, L59, L33, LC9, LH6, LMG, LY5, L31, LQ4, LQ9, L76, LY6, L92)
with Active Fuel Management™ and E85 Flex Fuel

If you encounter vehicles that exhibit the above conditions, refer to SI for the appropriate DTC (s) set. If no trouble is found, the cause may be due to an ECM ground terminal that has corroded with rust over time. Inspect the main engine wiring harness ground terminal (G103) for this condition.

The wire terminal (G103) attaches either to the front or to the rear of the right side cylinder head, depending on the model year of the Full Size Pickup and/or Utility Trucks. If the ECM ground terminal has been found to be corroded, then follow the service procedure outlined in this bulletin to correct the corrosion issue.

Engine Wiring Harness Ground Terminal Location (2007 Full-Size Pickup and/or Utility Trucks)

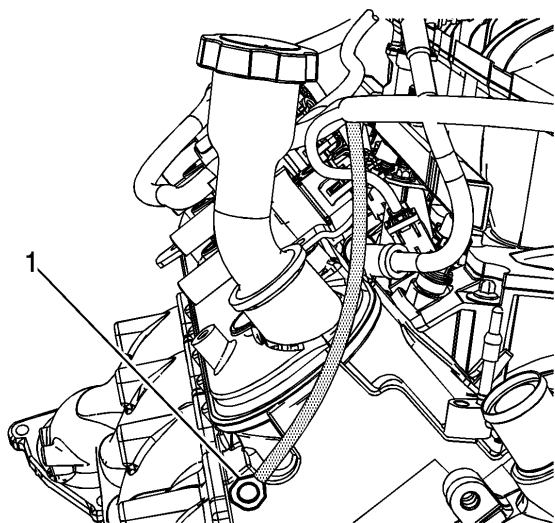

Engine Wiring Harness Ground Terminal Location (1999-2006 Full Size Pickup and/or Utility Trucks)

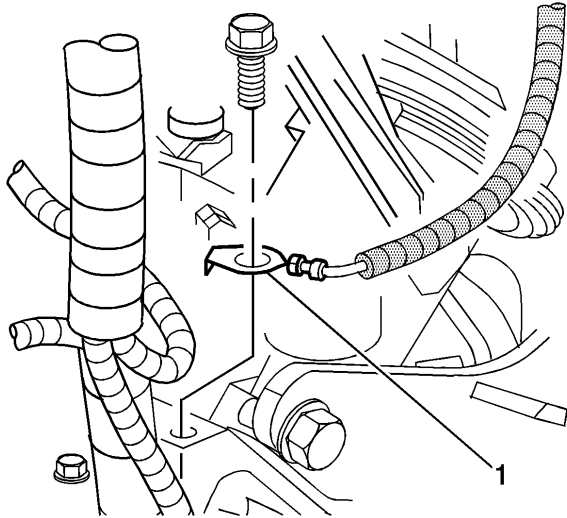

1. Remove either the nut or bolt securing the main engine wiring harness ground terminal (G103) to the right cylinder head. Refer to the above illustration to determine where the ground is located on the vehicle (1).
2. Remove all rust from the ground terminal, the cylinder head and the retaining nut or bolt.
3. Position the main engine wiring harness ground terminal and install the nut or bolt.

Tighten:

Tighten the retaining nut or bolt to 16 N·m (12 lb ft).

4. Apply some type of electrical moisture sealant to protect the harness terminal from further corrosion.

GM bulletins are intended for use by professional technicians, NOT a "do-it-yourselfer". They are written to inform these technicians of conditions that may occur on some vehicles, or to provide information that could assist in the proper service of a vehicle. Properly trained technicians have the equipment, tools, safety instructions, and know-how to do a job properly and safely. If a condition is described, DO NOT assume that the bulletin applies to your vehicle, or that your vehicle will have that condition. See your GM dealer for information on whether your vehicle may benefit from the information.