

GEAR SELECTOR LEVER—INCREASED EFFORT TO SHIFT FROM DRIVE TO PARK

TSB 04-22-12

FORD:
2002-2005 Explorer

MERCURY:
2002-2005 Mountaineer

ISSUE

Some 2002-2005 Explorer 4dr/Mountaineer vehicles, may require a greater effort to move the gear selector lever (shift lever) from drive to park. This may be due to a time delay with the brake shift interlock (BSI) pin retraction.

ACTION

To service, replace the BSI switch. Refer to the following Service Procedure.

SERVICE PROCEDURE

1. Remove the two (2) fasteners supporting the instrument panel knee bolster from below the steering column and remove the cover (Figure 1).

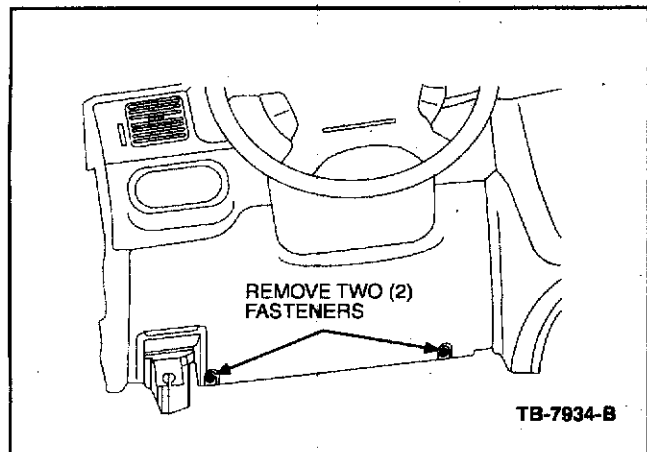

Figure 1 - Article 04-22-12

2. Remove the three (3) fasteners supporting the steering column lower shroud and remove the cover (Figure 2).

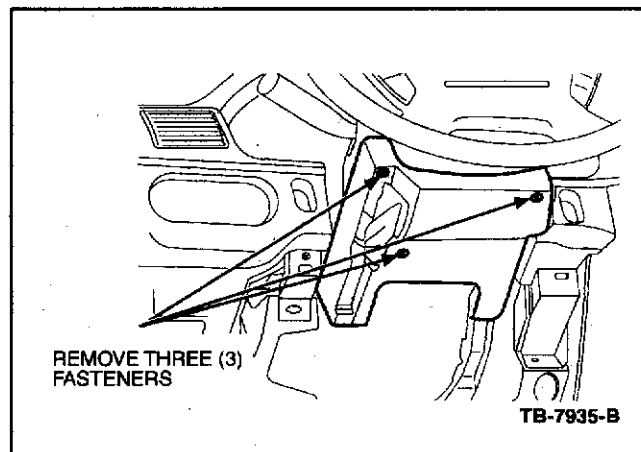

Figure 2 - Article 04-22-12

3. Remove the three (3) wiring bundle carrier fasteners from the bottom of the steering column to allow movement while removing the BSI switch. It may be necessary to release the connectors from the multifunction switch (Figure 3).

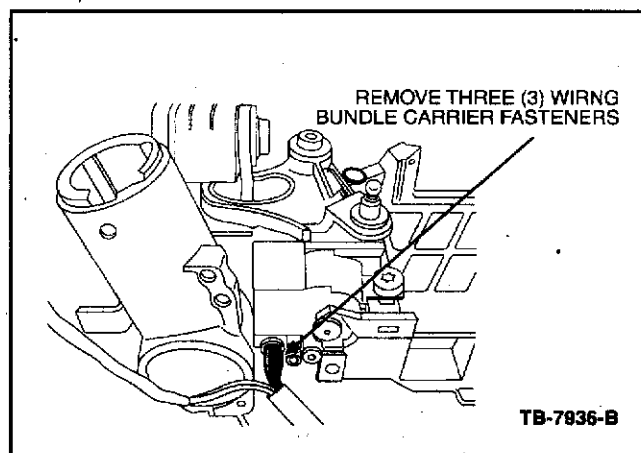

Figure 3 - Article 04-22-12

4. Remove the BSI fasteners (T-30 on the side and T-20 on the bottom) (Figure 4).

NOTE: The information in Technical Service Bulletins is intended for use by trained, professional technicians with the knowledge, tools, and equipment to do the job properly and safely. It informs these technicians of conditions that may occur on some vehicles, or provides information that could assist in proper vehicle service. The procedures should not be performed by "do-it-yourselfers". Do not assume that a condition described affects your car or truck. Contact a Ford, Lincoln, or Mercury dealership to determine whether the Bulletin applies to your vehicle. Warranty Policy and Extended Service Plan documentation determine Warranty and/or Extended Service Plan coverage unless stated otherwise in the TSB article. The information in this Technical Service Bulletin (TSB) was current at the time of printing. Ford Motor Company reserves the right to supercede this information with updates. The most recent information is available through Ford Motor Company's on-line technical resources.

TSB 04-22-12 (Continued)

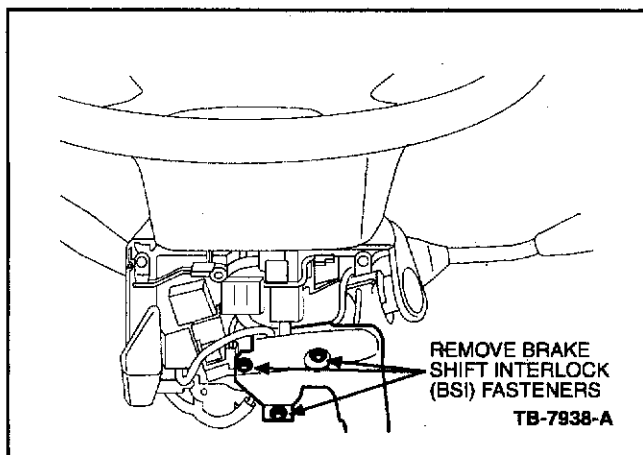

Figure 4 - Article 04-22-12

5. Pull the BSI tab on the bottom of the column downward to help free the BSI from the column housing.
6. Break the two (2) side tabs off the BSI by the white wiring connector (Figure 5).

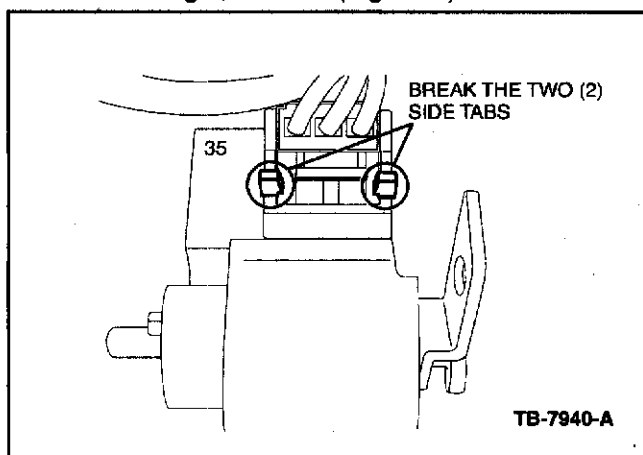

Figure 5 - Article 04-22-12

7. Push the locking tab on the white connector towards the wiring to release the connector from the BSI. Be careful not to damage the connector or wiring. If the connector does not free easily, a very small flat screwdriver may be used to help lift the locking tab (Figure 6).

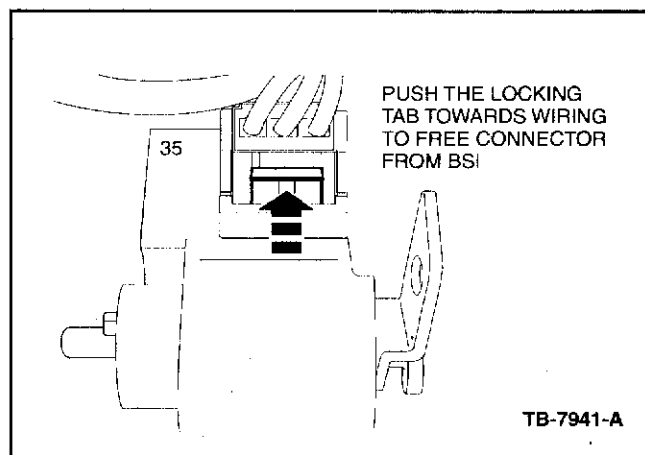

Figure 6 - Article 04-22-12

8. Connect the wiring to the new BSI. Ensure all clips are fully engaged to prevent the connector from pulling free.
9. Reinstall the BSI onto the steering column and reinstall fasteners (Figure 7).

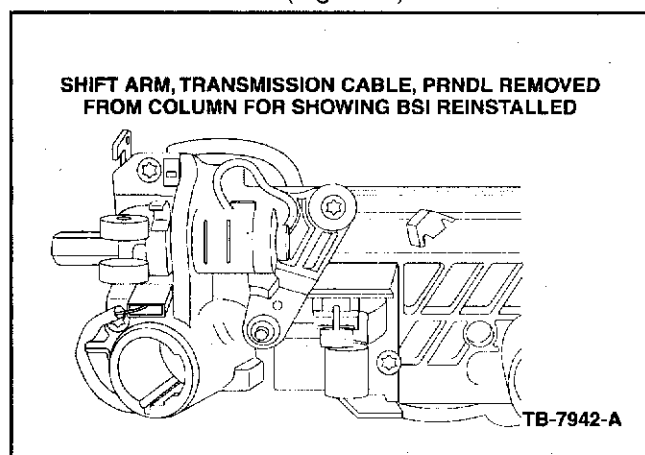

Figure 7 - Article 04-22-12

10. Check BSI function. With the key in the accessories or run position, press the brake pedal. The BSI pin should retract on brake application, and spring up one (1) second after releasing the brake pedal. Repeat several times.
11. Reinstall fasteners to connect wiring bundle carrier to the steering column. Make sure all connections to the multifunction switch unit are secured properly.
12. Reassemble steering column in reverse order. Ensure rubber gap hider around shift lever is properly seated on the shroud.
13. Cycle the shift lever from park to drive and drive back to park several times to verify improved shift effort.

PART NUMBER	PART NAME
1L2Z-3Z719-DA	BSI Switch

WARRANTY STATUS: Eligible Under Provisions Of
New Vehicle Limited
Warranty Coverage

OPERATION	DESCRIPTION	TIME
042212A	Replace The Brake Shift Interlock Switch (BSI)	0.5 Hr.

DEALER CODING

BASIC PART NO.	CONDITION CODE
3F770	42

630100