

## SECTION 206-05: Parking Brake and Actuation

2004 F-Super Duty 250-550/Excursion  
Workshop Manual

## REMOVAL AND INSTALLATION

[Procedure revision date: 05/24/2003](#)

## Shoes—Rear Wheel

[Printable View \(283 KB\)](#)

## Special Tool(s)

 ST1468-A	Brake Adjusting Gauge 206-D002 (D81L-1103-A) or equivalent
----------------------------------------------------------------------------------------------	------------------------------------------------------------------

## Removal



**WARNING:** Asbestos fiber dust can be present on brake and clutch assemblies and is hazardous if inhaled. Brake and clutch assemblies must be cleaned using a vacuum cleaner recommended for use with asbestos fibers such as a brake/clutch/service vacuum. The bag must be labeled per OSHA instruction, sealed, and the trash hauler notified as to the bag's contents. If a vacuum suitable for asbestos is not available, cleaning must be done wet. If dust generation is still possible, technicians must wear government-approved toxic dust purifying respirators.



**WARNING:** Occupational health and safety act (OSHA) requires areas where asbestos dust generation is possible to be isolated and posted with warning signs. Only technicians performing brake or clutch repair are to be present in the area.

1. Remove the rear disc brake rotor. For additional information, refer to [Section 206-04](#).
2. Disconnect the rear parking brake cable at the parking brake intermediate cable (2A793).

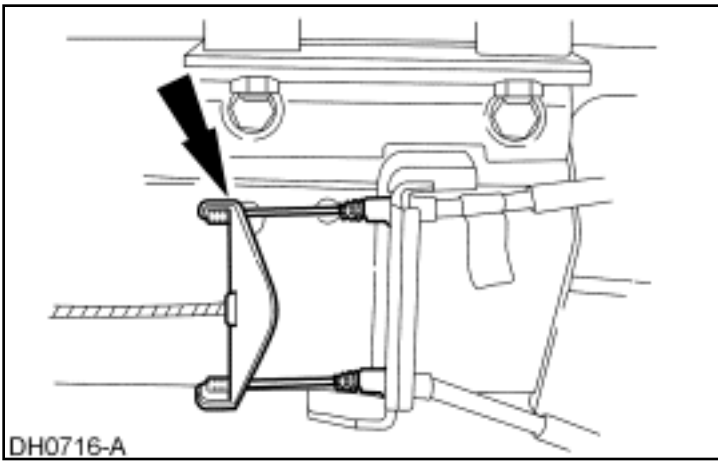

3. Disconnect the parking brake cable at the parking brake lever.

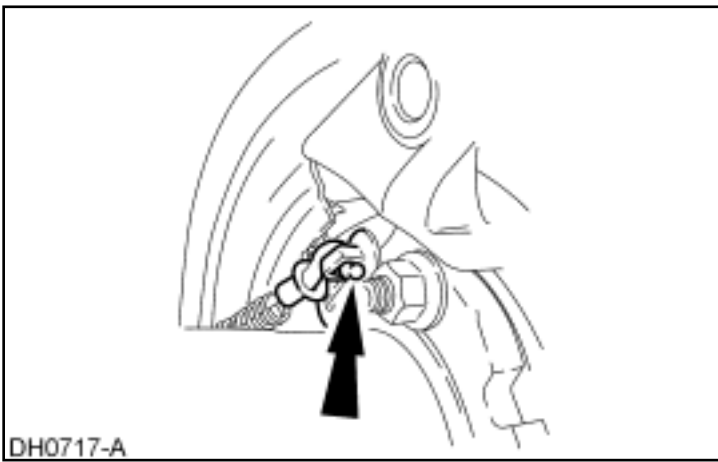

4. Remove the outboard brake shoe retracting spring.

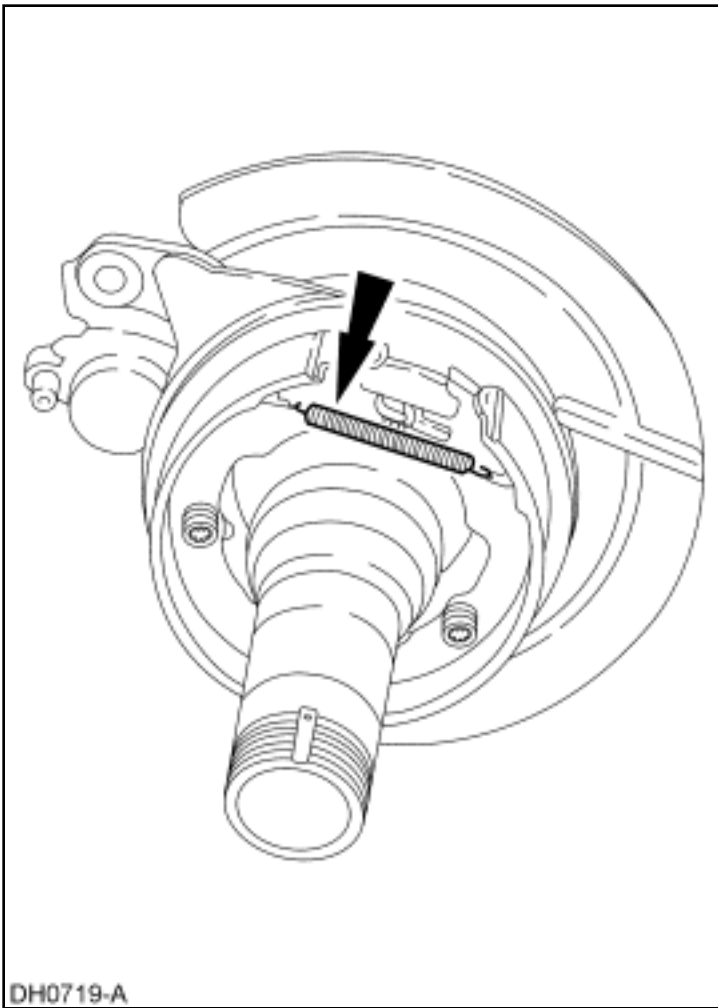

5. Remove the brake shoe adjusting screw spring.

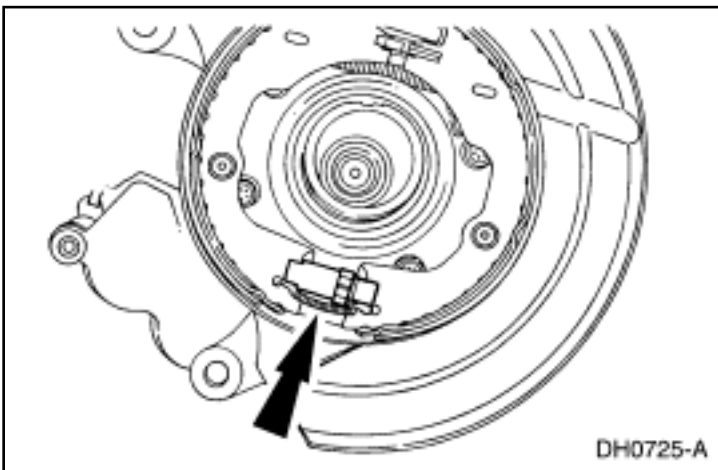

6. Remove the brake shoe hold-down springs.

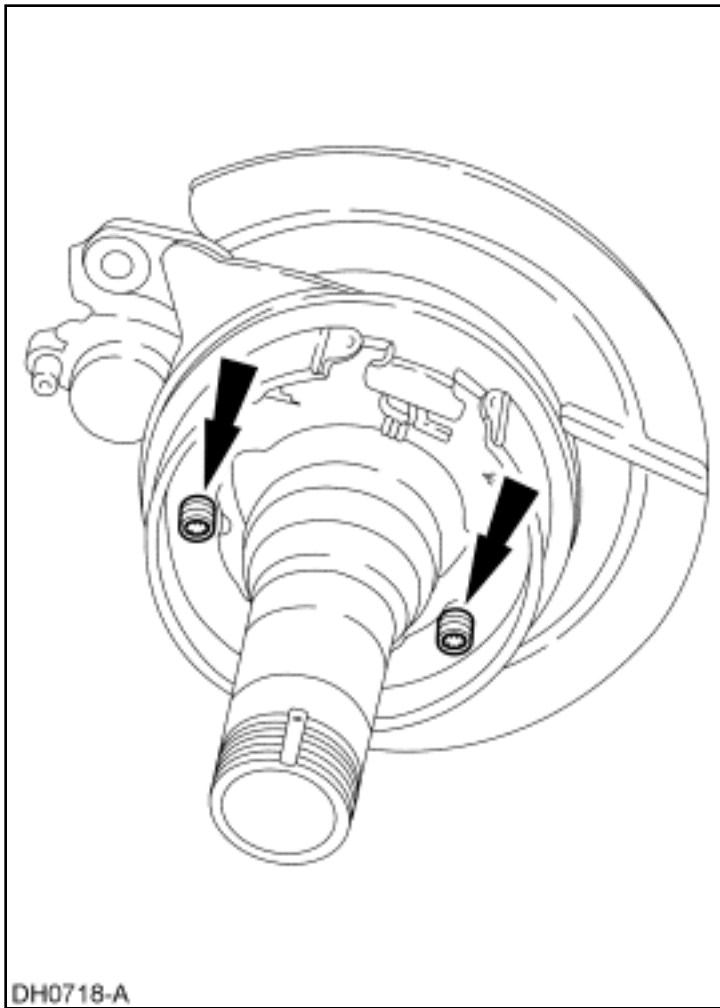

7. Remove the brake adjuster screw (2041).

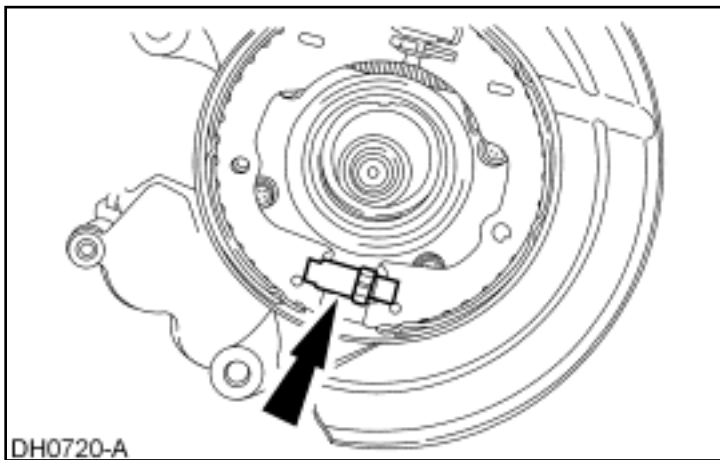

8. Remove the parking brake shoe and linings (2N712) along with the inboard brake shoe retracting spring.

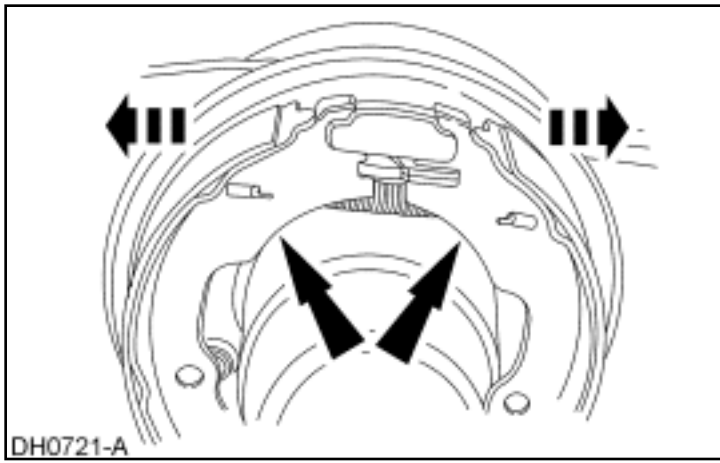

9. Inspect the components for excessive wear or damage and install new as required.

## Installation

1. **NOTE:** Make sure the inboard brake shoe retracting spring is attached to the parking brake shoe.

Install the LH parking brake shoe and brake shoe hold-down spring, along with the inboard brake shoe retracting spring.

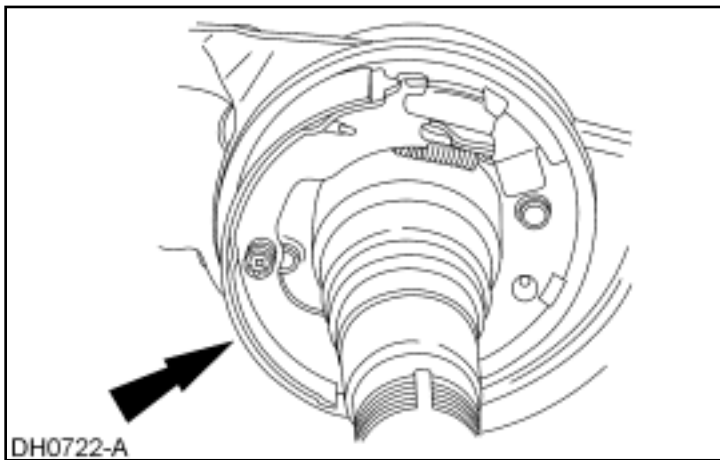

2. Connect the inboard brake shoe retracting spring to the RH parking brake shoe, and install the RH parking brake shoe and the brake shoe hold-down spring.

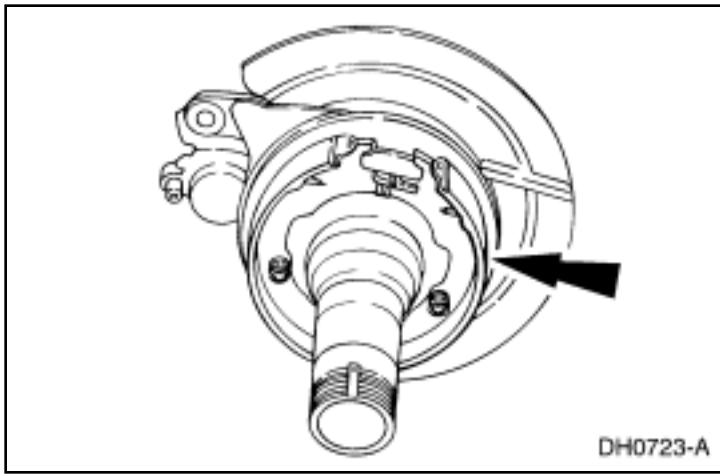

3. Install the brake adjuster screw.

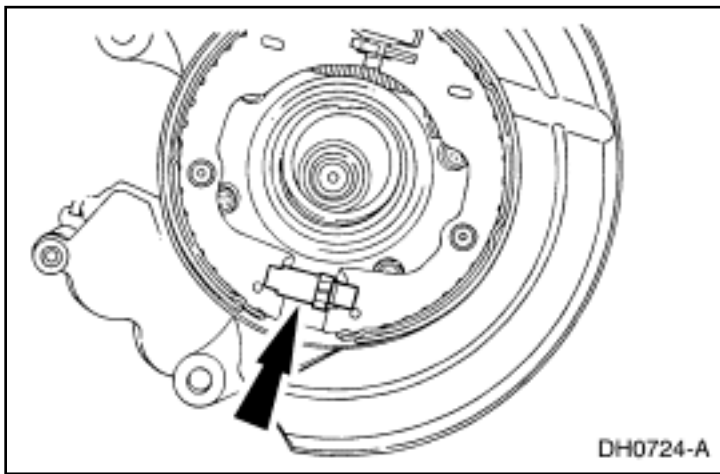

4. Install the brake shoe adjusting screw spring.

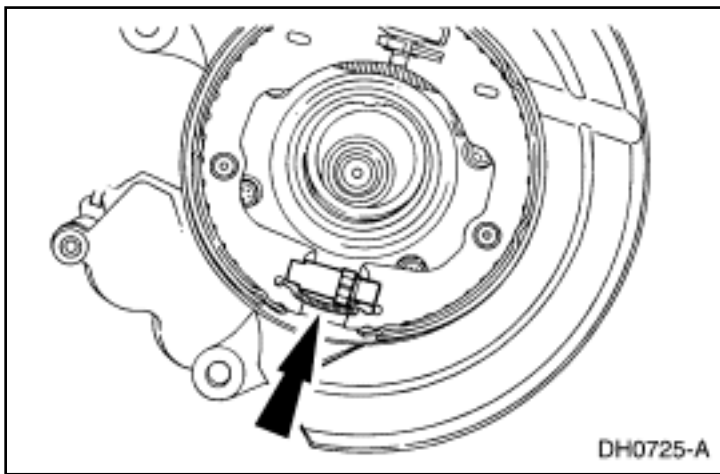

5. **NOTE:** The outboard brake shoe retracting spring mounts above the inboard brake shoe retracting spring.

Install the outboard brake shoe retracting spring.

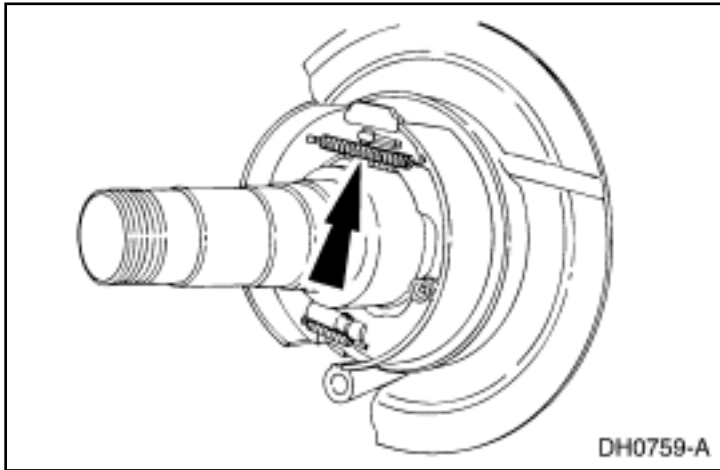

6. Connect the parking brake cable at the parking brake lever.

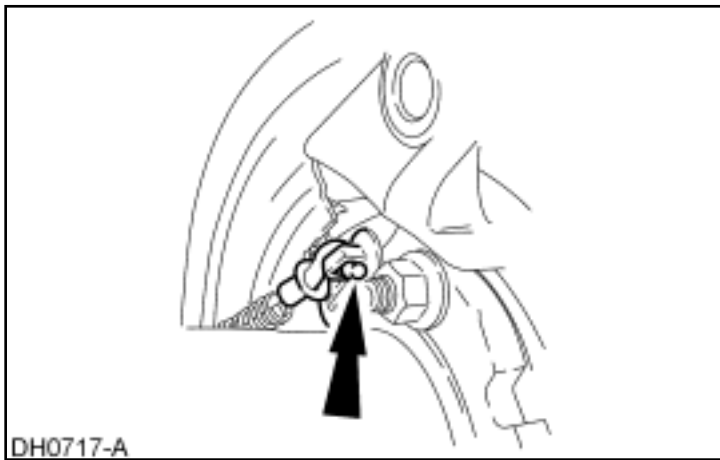

7. Connect the rear parking brake cable at the parking brake intermediate cable.

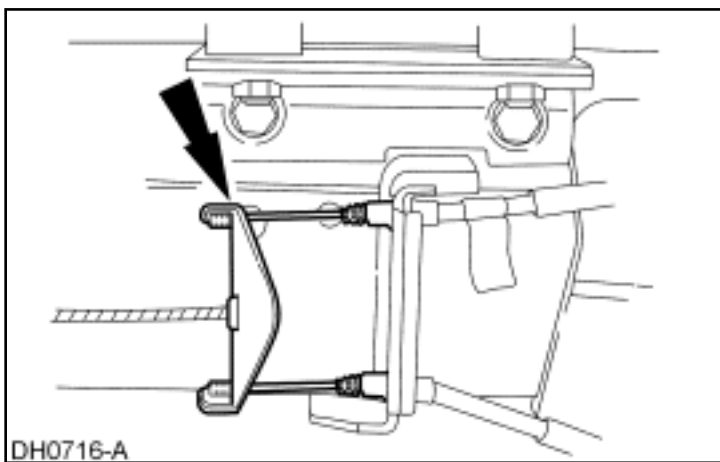

8. Install the rear disc brake rotor. For additional information, refer to [Section 206-04](#).
  - Use the Brake Adjusting Gauge to set the rear brake shoe and lining diameter to 0.76 mm (0.030 in.) less than the inside diameter of the drum portion of the rear disc brake rotor.



9. Burnish the parking brake shoe and linings.
  1. Accelerate the vehicle to 40 km/h (25 mph).
  2. Shift the transmission to NEUTRAL.
  3. Slowly apply the parking brake control (2780) to approximately one-half to three-quarters of its travel.
  4. Allow the vehicle to come to a complete stop.
  5. Release the parking brake.

SECTION 205-02F: Wheel Hubs and Bearings —  
Full Floating Axle — Ford

## REMOVAL AND INSTALLATION

2004 F-Super Duty 250-550/  
Excursion Workshop Manual[Procedure revision date: 05/24/2003](#)**Hub**[Printable View \(353 KB\)](#)

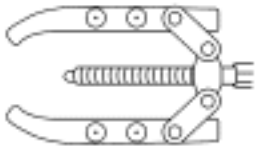
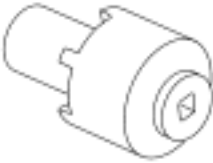
## Special Tool(s)

 ST1260-A	2-Jaw Puller 205-D026 (D80L-1002-L) or Equivalent
 ST1868-A	Socket, Ford Axle Locknut 205-448
 ST1543-A	Step Plate 205-D018 (D80L-630-7) or Equivalent

## Material

Item	Specification
SAE 75W-140 Synthetic Rear Axle Lubricant F1TZ-19580-B	WSL-M2C192-A

**Removal**

1. Set the parking brake.
2. Loosen the retaining bolts.

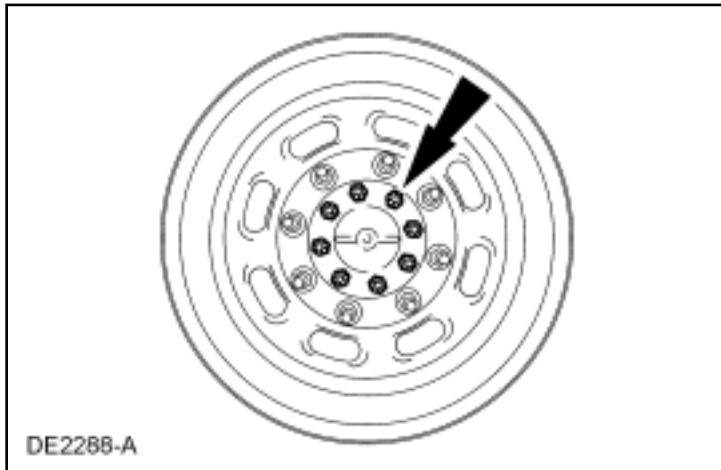

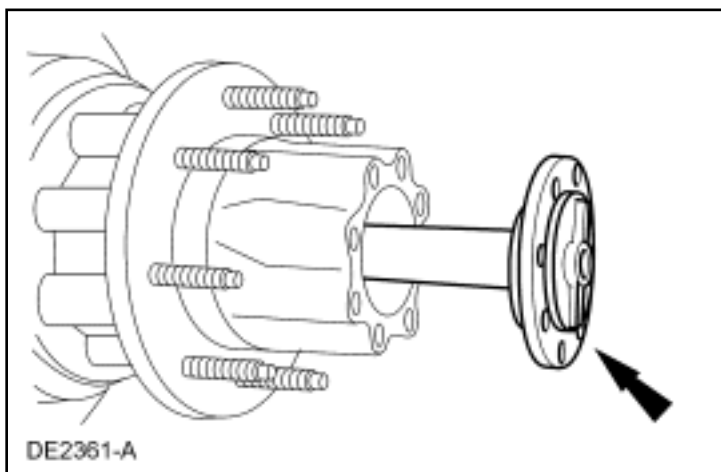

3. Raise the vehicle to the desired working height, keeping the axle parallel with the floor. For additional information, refer to [Section 100-02](#).
4. Release the parking brake.
5. Remove the wheel(s). For additional information, refer to [Section 204-04](#).
6. Remove the brake caliper and rotor on the single rear wheel axle. For additional information, refer to [Section 206-04](#).
7. Remove the retaining bolts and axle shaft.

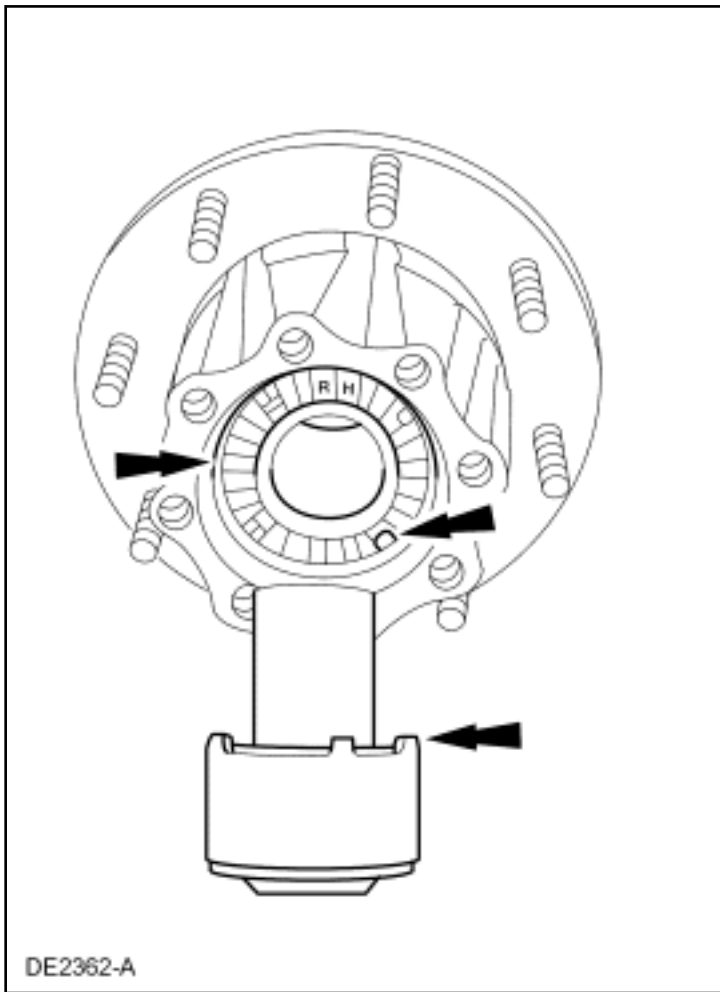

8.  **CAUTION:** The hub nuts are right-hand thread (right hub) and left-hand thread (left hub). Each hub nut is stamped RH or LH.

Install the Ford Axle Locknut Socket so that the drive tangs of the tool engage the four slots in the hub nut.



9.  **CAUTION:** Discard the hub nut if the hub nut comes apart during removal.

 **CAUTION:** Under no circumstances are power tools to be used when performing these operations.

**NOTE:** The hub nut will ratchet during this operation.

Remove the hub nut (counterclockwise for right-hand thread; clockwise for left-hand thread).

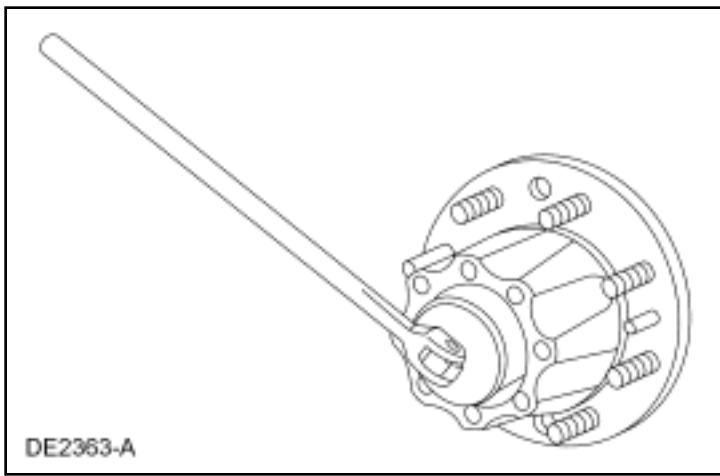

10. Install the Step Plate.

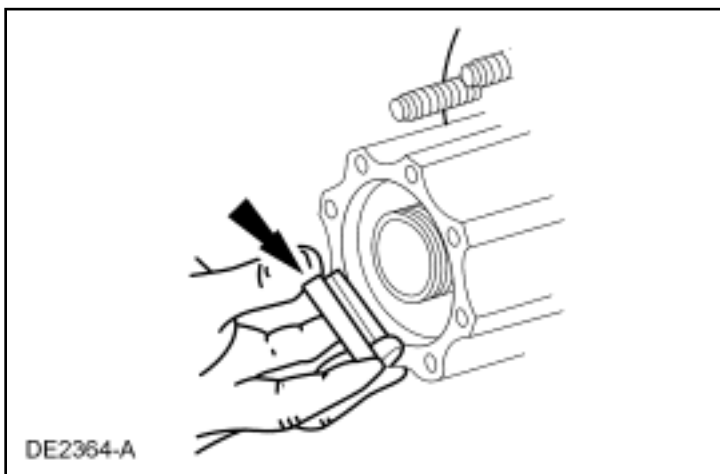

11. Install the 2-Jaw Puller and loosen the rear hub to the point of removal.

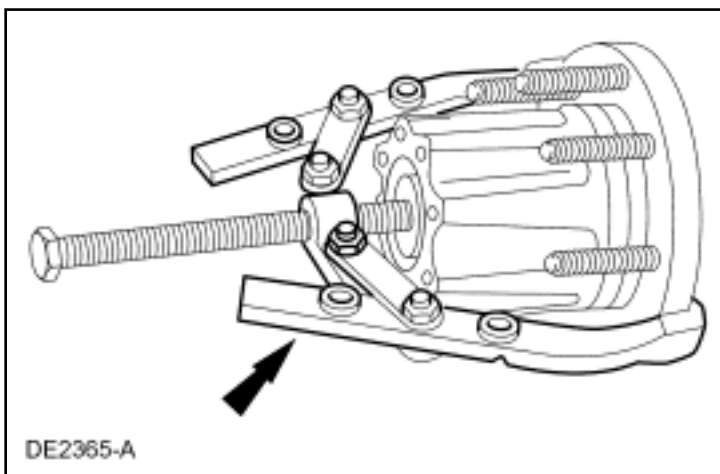

12.  **CAUTION: Do not drop the outer hub bearing when removing the hub.**

Remove the rear hub assembly.

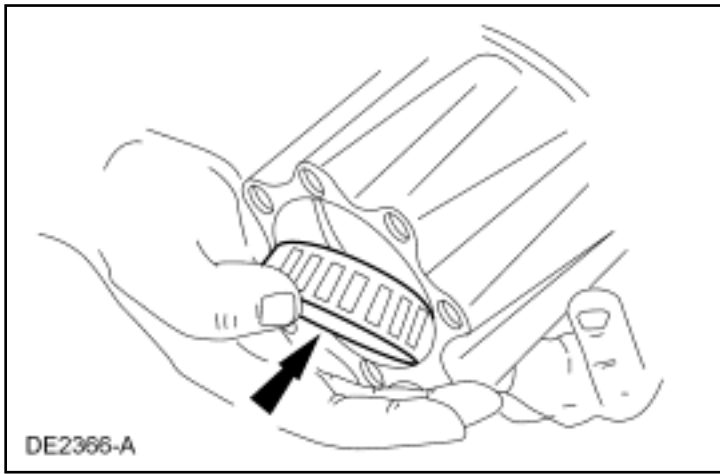

13.  **CAUTION: Install a new hub seal each time the hub assembly is removed.**

**NOTE:** The inner bearing is located behind the hub seal.

Pack each bearing and replace the hub seals. For additional information, refer to [Wheel Bearings, Wheel Hub Seal and Wheel Bearing Cups](#) in this section.

14.  **CAUTION: Use extreme care not to scratch or gouge the seal or bearing surfaces.**

If after hub removal, the hub seal or seal inner sleeve remains on the spindle, remove it as shown using the Step Plate and the 2-Jaw Puller.

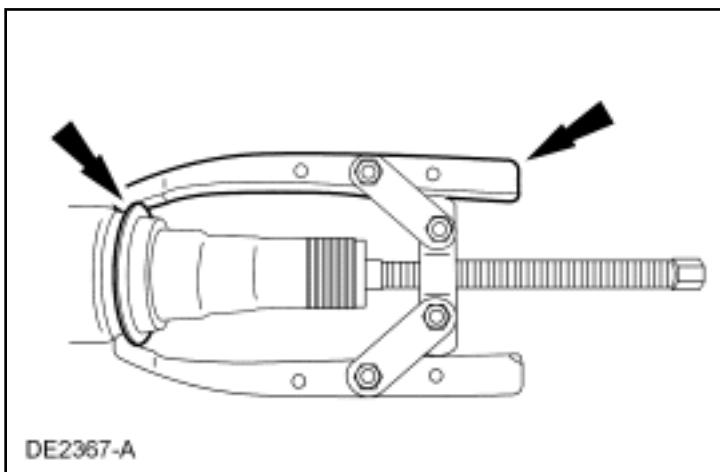

15. Inspect the seal surface and inner shoulder for scratches and damage.
- Remove all scratches, gouges or galling damage with No. 600 or finer crocus cloth.

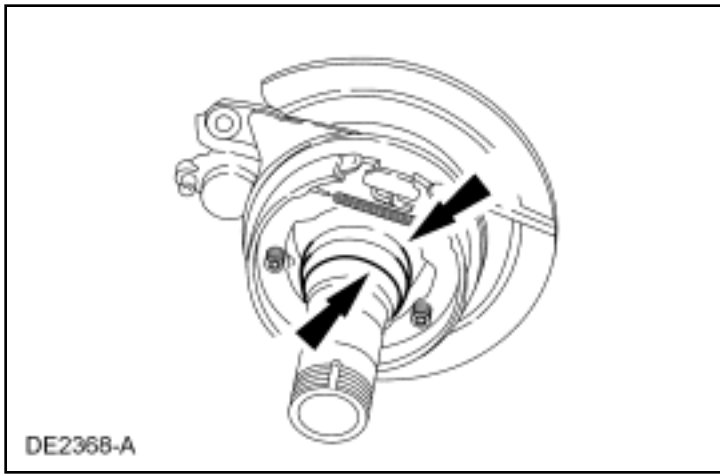

## Installation

1. **NOTE:** Clean the spindle thoroughly after removing the rear hub.

Coat the spindle with axle lubricant.

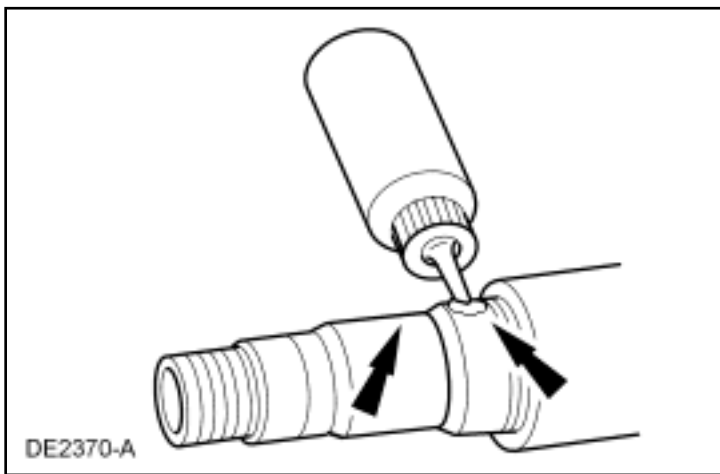

2.  **CAUTION:** The hub bearings must be prelubed prior to installation.

Fill the hub cavity with 29.6 ml (1 oz) of axle lubricant.

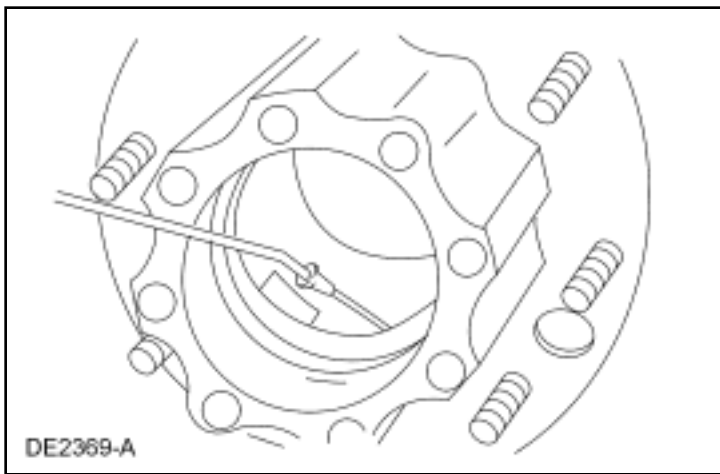

3.  **CAUTION:** Use extreme care not to damage the hub seal by allowing it to contact the spindle during installation.

**NOTE:** Coat the spindle and hub seal inside diameter with axle lubricant.

**NOTE:** Installing the rear hub in this manner causes the outer bearing to act as a pilot making the installation easier.

Push the rear hub and outer bearing onto the spindle as an assembly.

- Hold the outer bearing seated and use the bearing as a pilot.

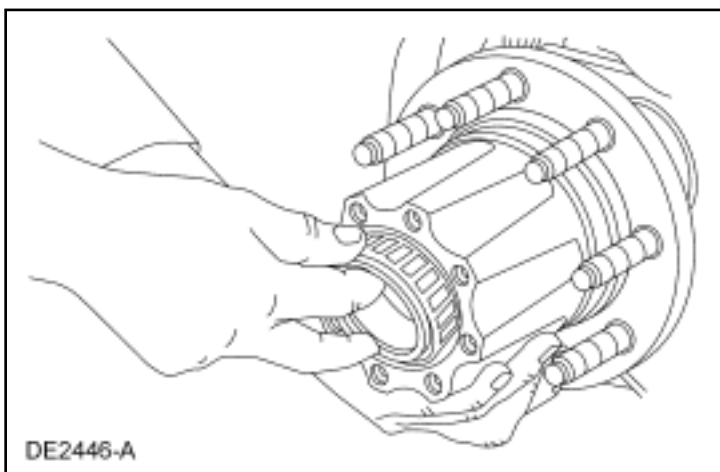

4.  **CAUTION:** Install a new hub nut if the hub nut comes apart during installation.

 **CAUTION:** Make sure the hub nut tab is located in the keyway prior to thread engagement.

Install the hub nut on the spindle.

- Turn the hub nut clockwise for right-hand thread or counterclockwise for left-hand thread.

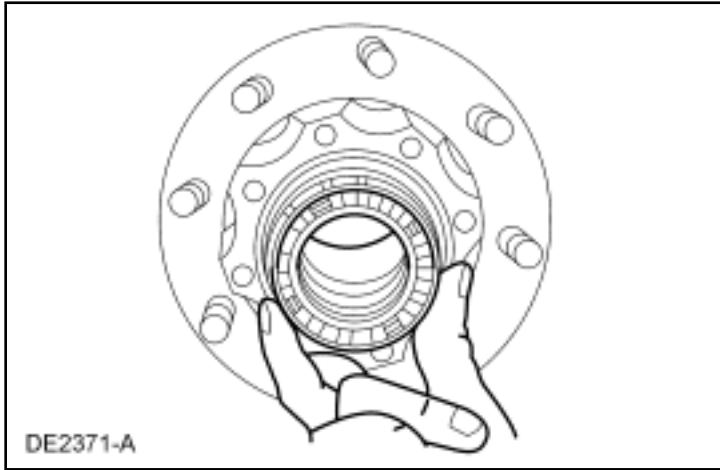

5. Position the Ford Axle Locknut Socket on the hub nut.

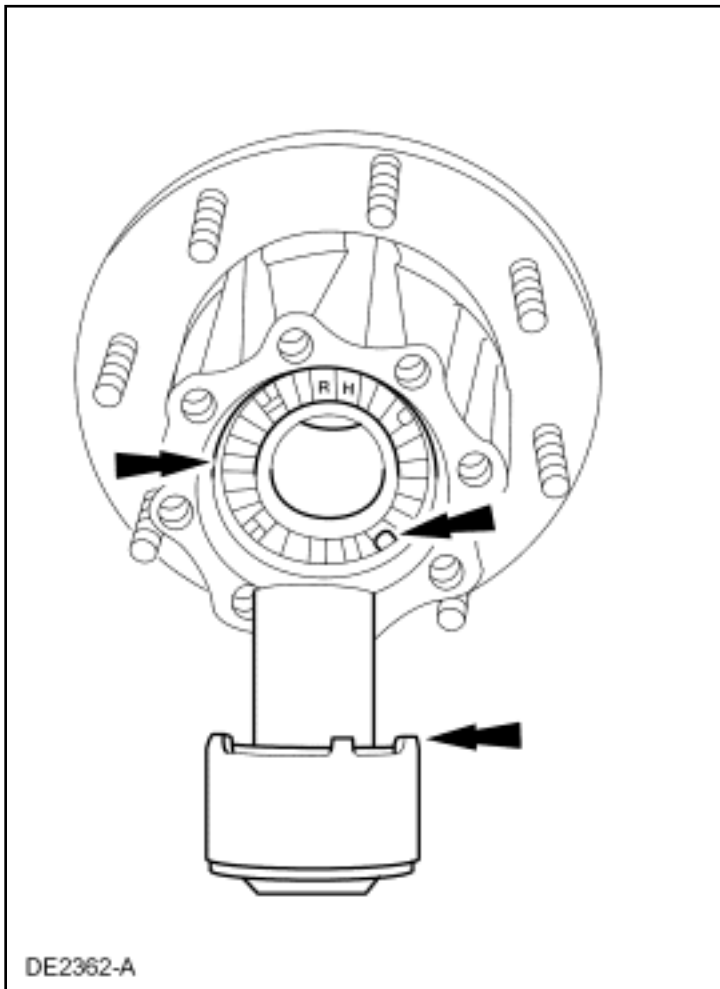

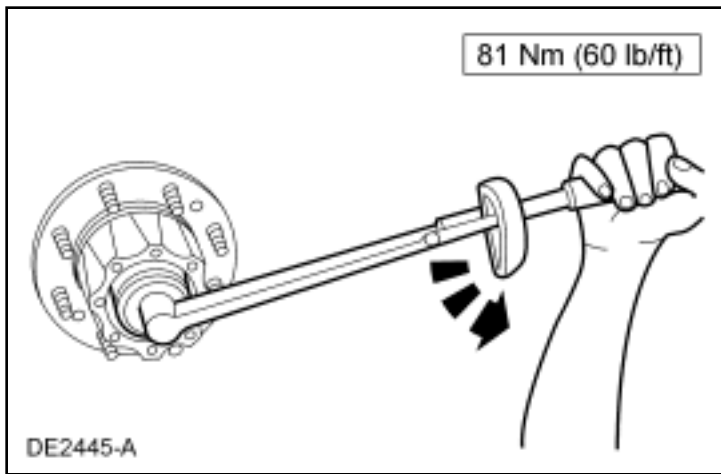

6.  **CAUTION:** Under no circumstances are power tools to be used when performing these operations.

**NOTE:** The hub nut will ratchet as torque is applied.

Tighten the hub nut, rotating the rear hub occasionally while tightening.

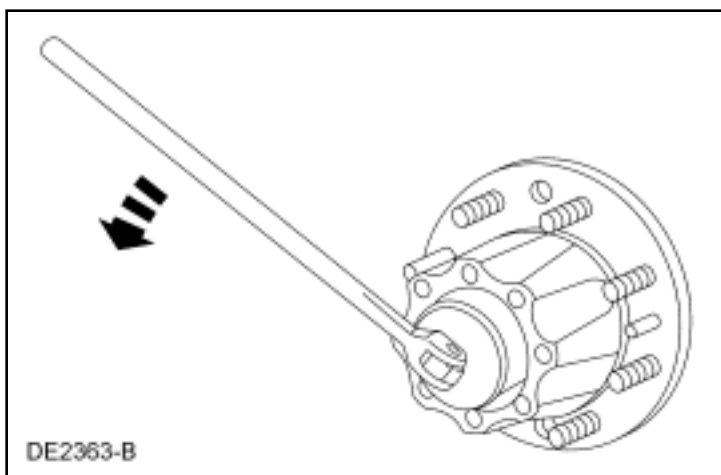

7. Adjust hub nuts as follows:
- For new bearings, ratchet back five teeth or notches (1/8 turn) on the hub nut. Five notches must be felt during this operation in order to have performed it correctly.
  - For used bearings, ratchet back seven teeth or notches (1/6 turn) on the hub nut. Seven notches must be felt during this operation to have performed it correctly.
8. Inspect the axle shaft O-ring seal for cracks, nicks or wear and replace it if required.

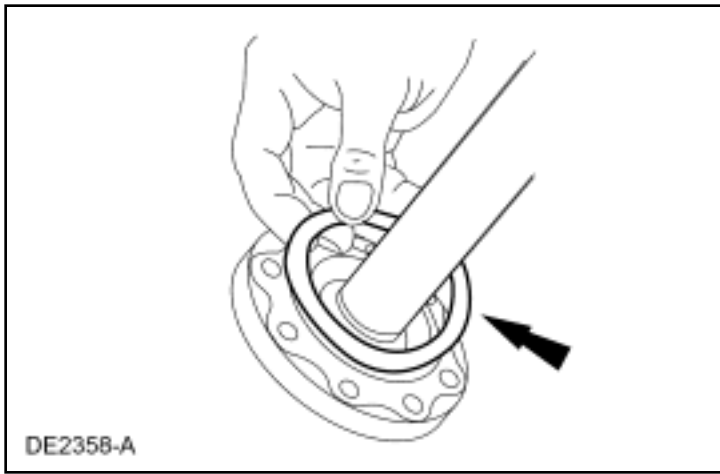

9. **NOTE:** Lubricate the O-ring seal with lubricant prior to installation of axle shaft.

Install the axle shaft.

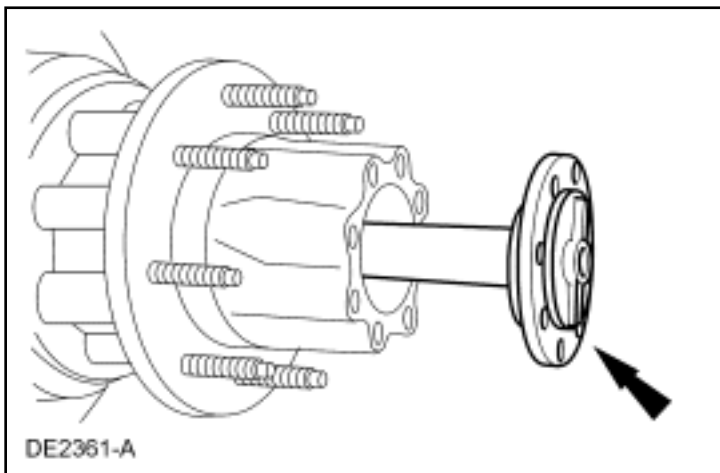

10. **NOTE:** Coat the threads of the retaining bolts with Stud and Bearing Mount E0AZ-19554-BA or equivalent meeting Ford specification WSK-M2G349-A1.

Install and tighten the retaining bolts until they seat.

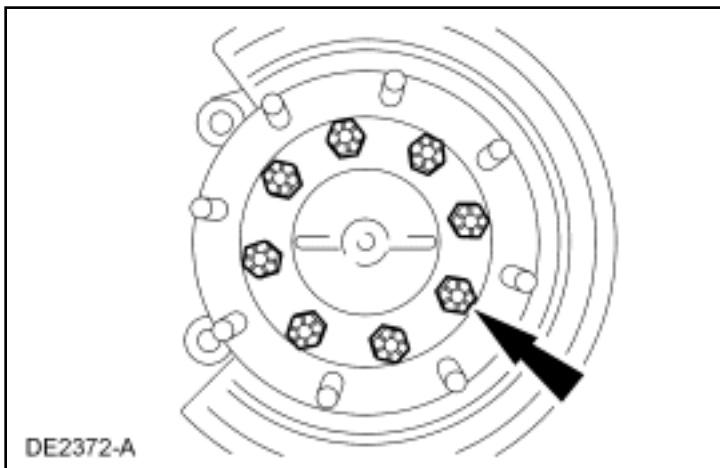

11.  **CAUTION: Remember, the last step of this procedure is to tighten the axle shaft bolts to specification, after the wheel lug nuts have been tightened.**

Install the brake rotor and caliper on the single rear wheel axles. For additional information, refer to [Section 206-04](#).

12. Install the wheels and tires but do not tighten the lug nuts to specification at this time.
13. Check the axle lubricant level. For additional information, refer to [Section 205-02D](#).
14. Lower the vehicle.
15. Tighten the wheel lug nuts. For additional information, refer to [Section 204-04](#).
16. Tighten the axle shaft retaining bolts.

