

SECTION 204-01: Front Suspension

REMOVAL AND INSTALLATION



2004 Taurus/Sable Workshop Manual
[Procedure revision date: 10/26/2006](#)

Ball Joint



[Printable View \(188 KB\)](#)

Special Tool(s)

 <p>ST1172-A</p>	<p>Installer/Remover, C-Frame and Screw 205-086 (T74P-4635-C)</p>
 <p>ST3036A</p>	<p>Ball Joint Adapter Set 204-D024</p>

Removal

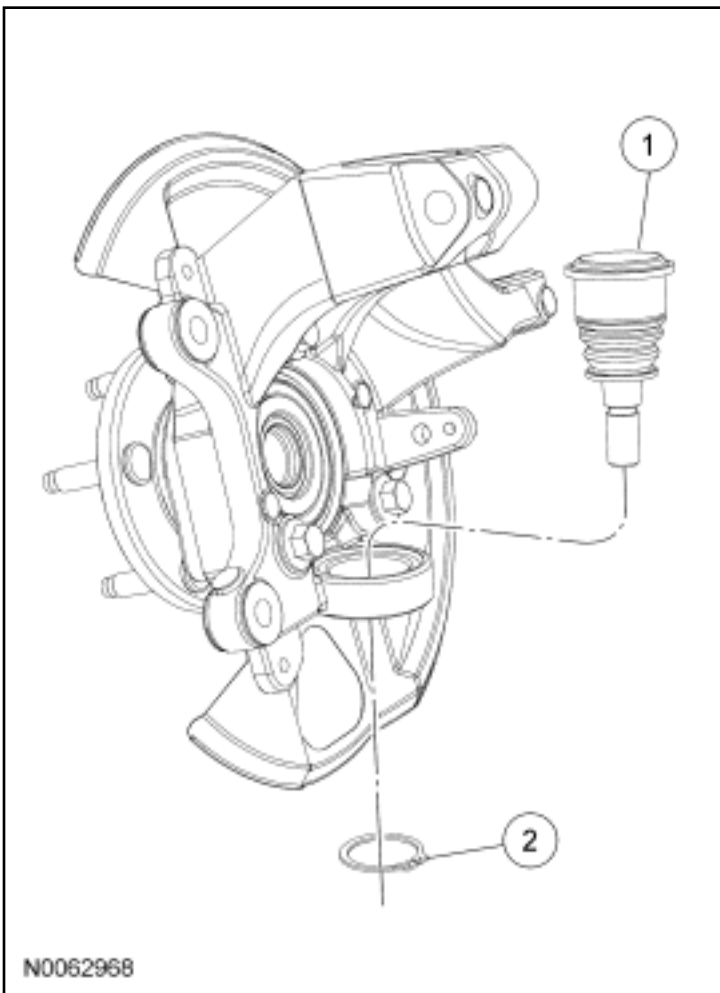

Item	Part Number	Description
1	3050	Ball joint
2	—	Snap ring (part of 3050)

1. Remove the wheel knuckle. For additional information, refer to [Wheel Knuckle](#) in this section.
2. Remove the snap ring.
3.  **CAUTION: To avoid damage to the components, do not use heat to aid ball joint removal.**

Using the special tools or an equivalent ball joint press and adapters, remove the ball joint from the wheel knuckle.

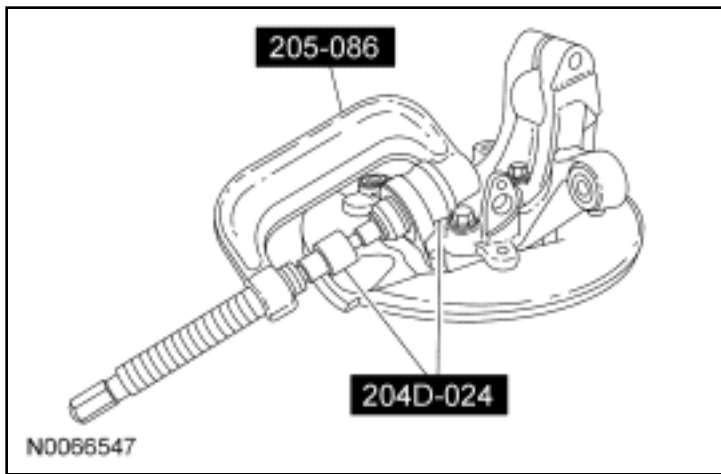

Installation

1.  **CAUTION:** To avoid damage to components, do not use heat to aid installation.

 **CAUTION:** The ball joint is installed with the dust boot attached to the ball joint. Do not damage the ball joint boot during installation.

Using the special tools or an equivalent ball joint press and adapters, install the ball joint into the wheel knuckle.

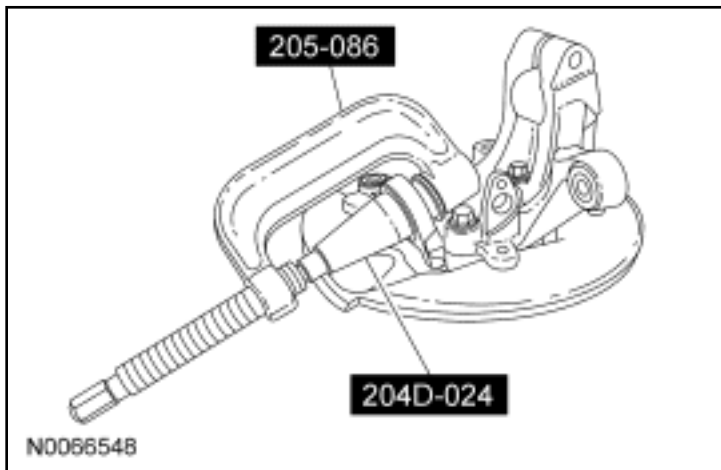

2. Install the snap ring.
3. Install the wheel knuckle. For additional information, refer to [Wheel Knuckle](#) in this section.

SECTION 204-01: Front Suspension

REMOVAL AND INSTALLATION



2004 Taurus/Sable Workshop Manual
[Procedure revision date: 07/02/2003](#)

Wheel Knuckle

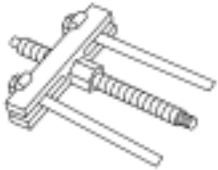
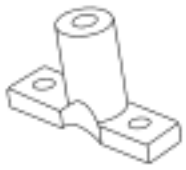

[Printable View \(549 KB\)](#)

Special Tool(s)

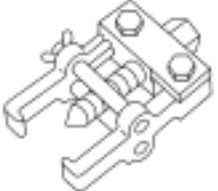
 ST1516-A	Remover/Installer, Front Wheel Hub 204-069 (T81P-1104-C)
 ST1517-A	Adapter, Wheel Hub 205-237 (T86P-1104-A1)
 ST1515-A	Installer, Halfshaft 204-067 (T81P-1104-A)
 ST1518-A	Remover, Wheel Stud (Metric) 204-085 (T83P-1104-BH1)
 ST1263-A	Remover, Steering Arm 211-003 (T64P-3590-F)

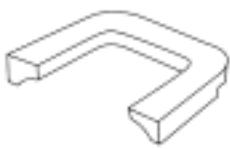
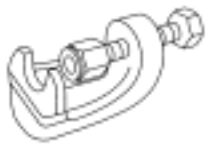
 <p>ST2461-A</p>	<p>Adapter for 211-S200 211-211 (T96P-3010-A1)</p>
 <p>ST1106-A</p>	<p>Remover, Tie-Rod End 211-001 (TOOL-3290-D) or equivalent</p>

Removal



CAUTION: Suspension fasteners are critical parts because they affect performance of vital components and systems and their failure can result in major service expense. A new part with the same part number must be used if installation is necessary. Do not use a new part of lesser quality or substitute design. Torque values must be used as specified during reassembly to make sure of correct retention of these parts.

All vehicles

1.  **CAUTION:** Discard the wheel hub retainer (3B477). It is a torque prevailing design and cannot be reused. If loosened, the retainer must be removed and a new one installed.

NOTE: Make sure the steering wheel is in the unlocked position.

Remove the hub cap or wheel cover, the wheel hub retainer, and the washer. Discard the retainer.

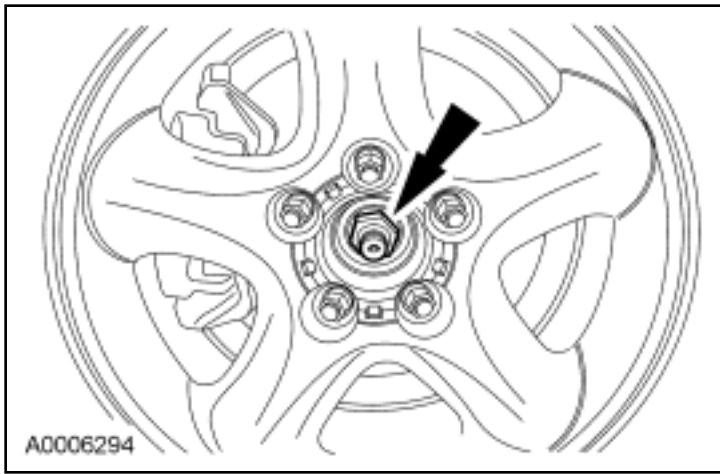

2. Remove the front brake disc. For additional information, refer to [Section 206-03](#).
3. Remove and discard the cotter pin and nut.

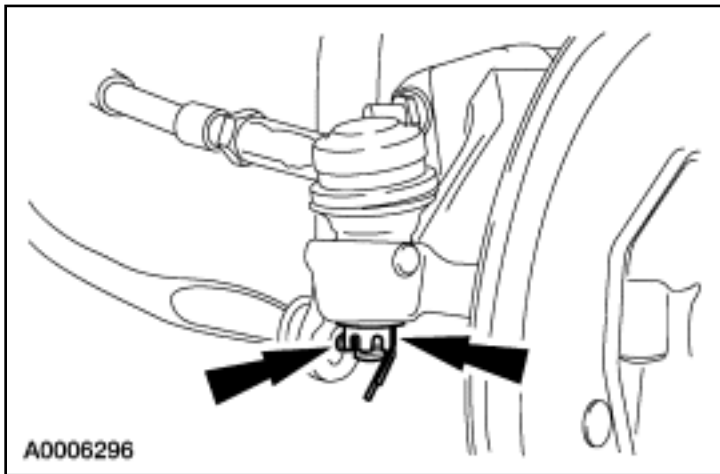

4.  **CAUTION: Do not damage the tie-rod end boot when installing the special tool.**

NOTE: Remove the adapter from the ball end of the special tool. Apply a small amount of grease to the tie-rod end stud and the ball of the special tool.

Using the special tools, disconnect the tie-rod end.

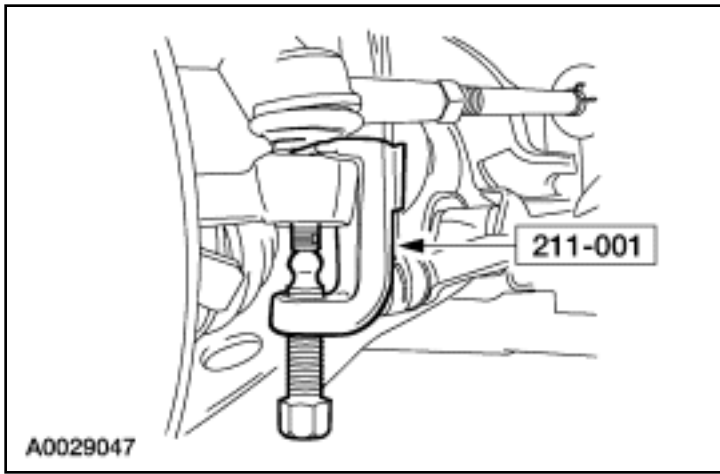

Vehicles equipped with ABS

5. Remove the bolt and detach the ABS sensor.

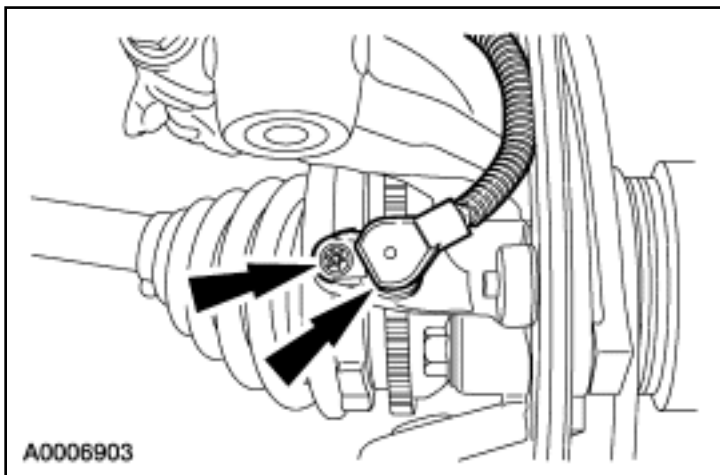

6. Unclip the ABS sensor wire retainer and position the sensor out of the way.

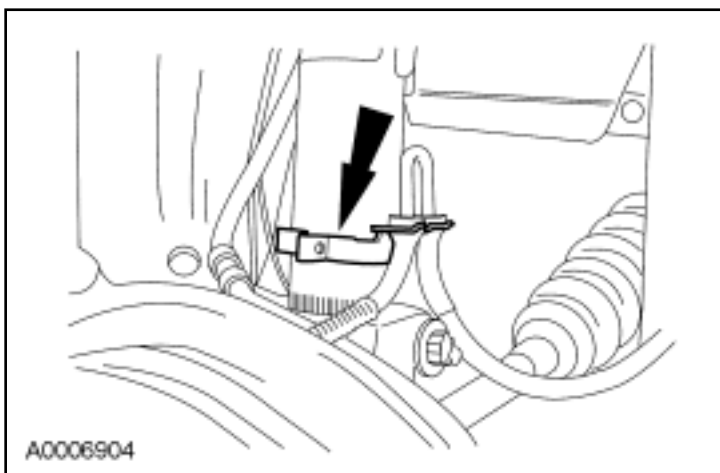

All vehicles

7. Remove and discard the nut.

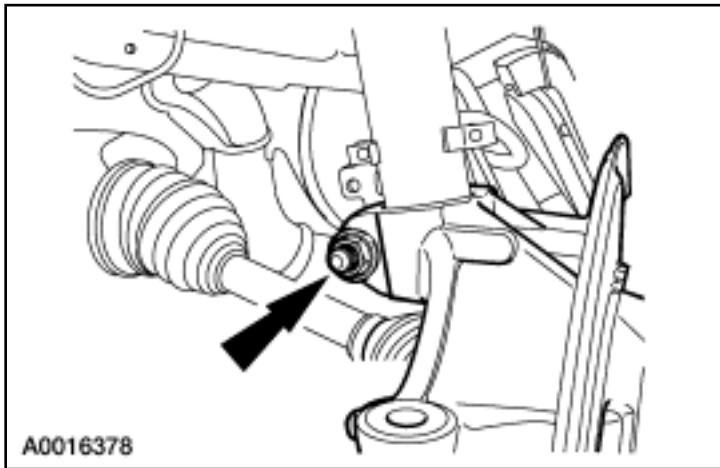

8. Remove and discard the nut.

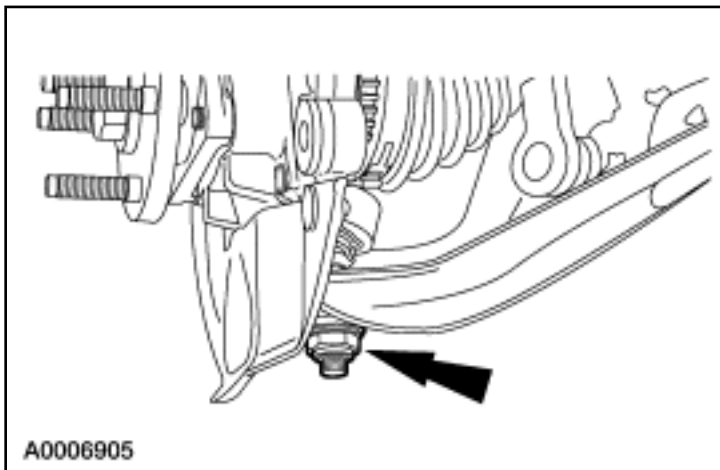

9. Using the special tools, disconnect the ball joint from the lower arm.

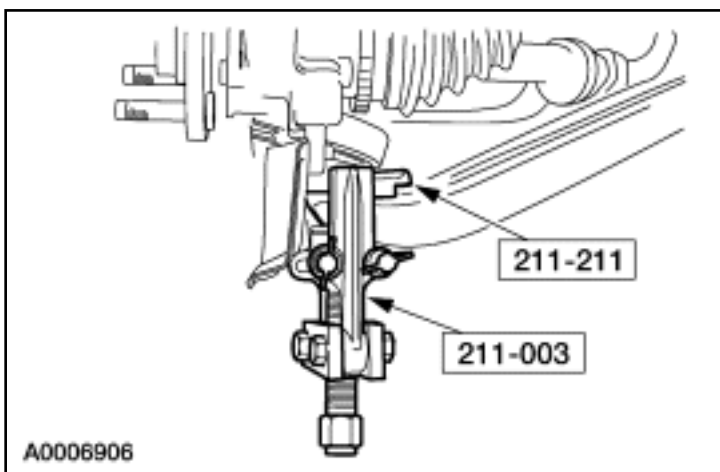

10. Using a pry bar, push the lower arm down until the ball joint is free of the arm.

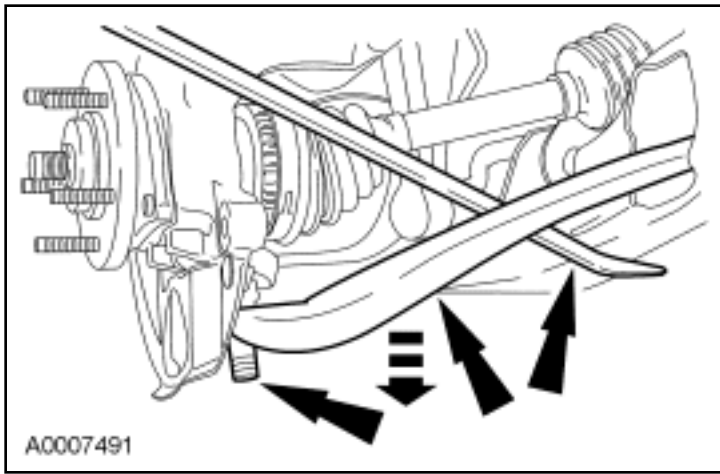

11.  **CAUTION:** Do not allow the halfshaft to move outboard. Over-extension of the tripod CV joint can result in separation of internal parts, causing failure of the halfshaft.

NOTE: Hold the threaded rod while turning the nut.

Using the special tools, press the halfshaft from the wheel bearing and hub. Wire the halfshaft in a level position.

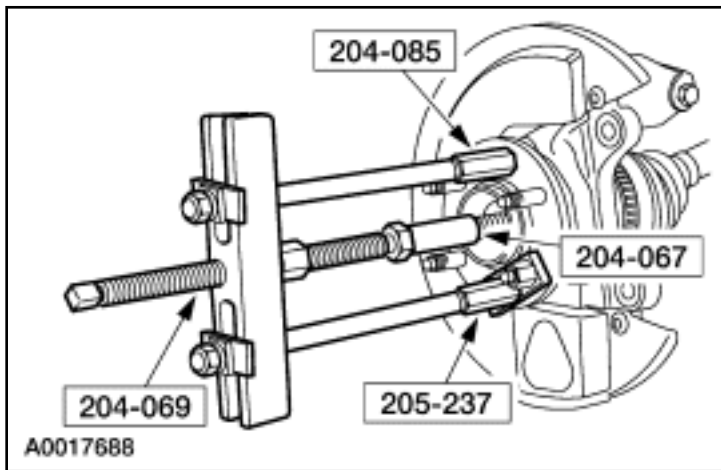

12. Remove the flag bolt and the knuckle.

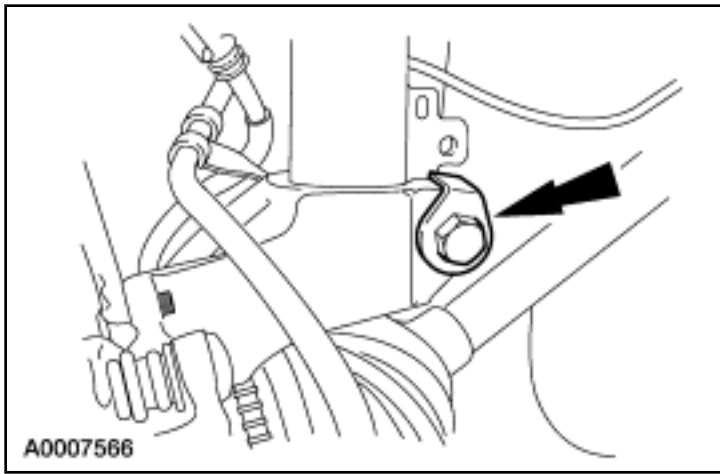

13. If necessary, remove the wheel hub and bearing. For additional information, refer to [Wheel Bearing and Hub](#) in this section.

14.  **CAUTION: Use care not to damage the knuckle or dust shield when drilling out the rivets.**

If necessary, remove the dust shield.

1. Using a 5.5 mm (0.22 in) drill bit, drill out the rivets. If a larger bit is needed, do not use a bit larger than 6 mm (0.24 in).
2. Remove the dust shield.

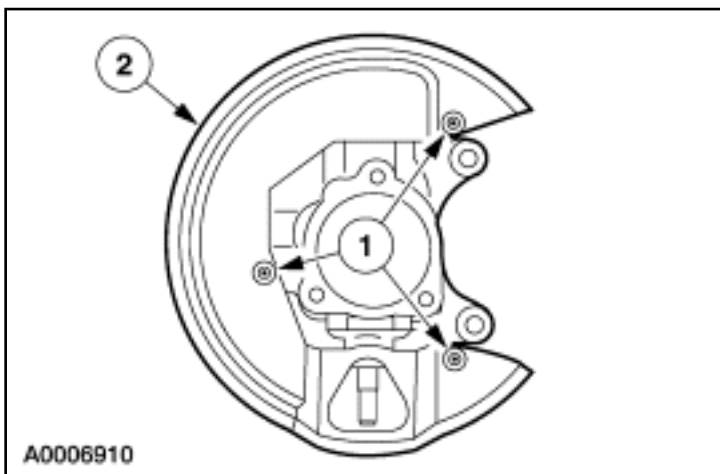

Installation

All vehicles

1.  **CAUTION: Use only the appropriate size aluminum rivets. Do not use steel rivets. Galvanic corrosion can occur.**

If removed, install the dust shield.

1. Position the dust shield.
2. Install the rivets.

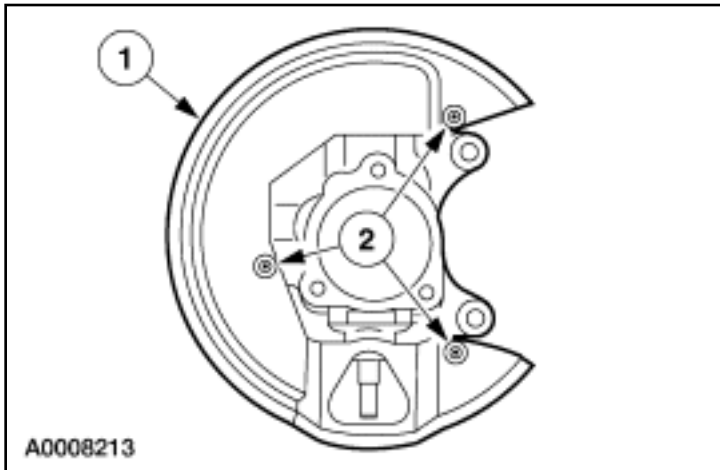

2. If removed, install the wheel hub and bearing. For additional information, refer to [Wheel Bearing and Hub](#) in this section.

3. Position the knuckle on the strut and install the flag bolt.

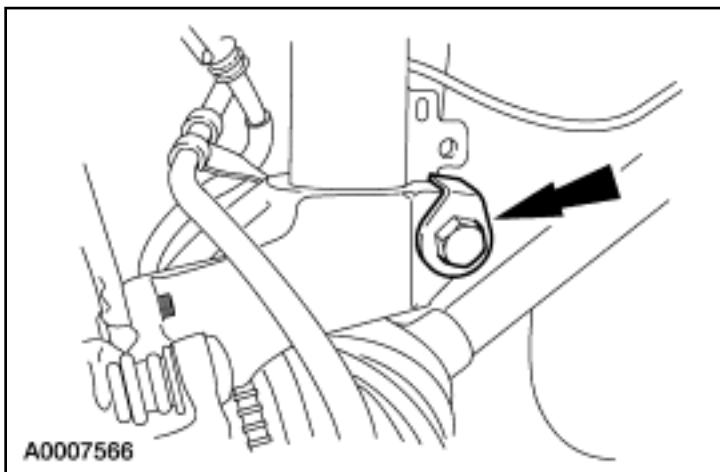

4. Using the special tools, press the halfshaft into the wheel bearing and hub.

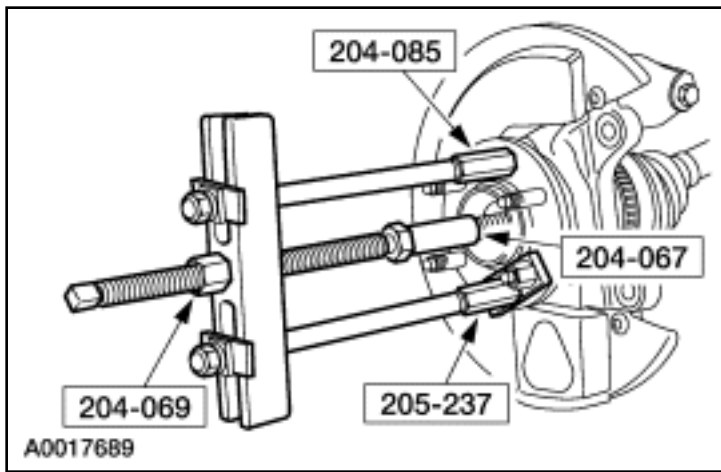

5. Using a pry bar, push the lower arm down until the ball joint can be installed.

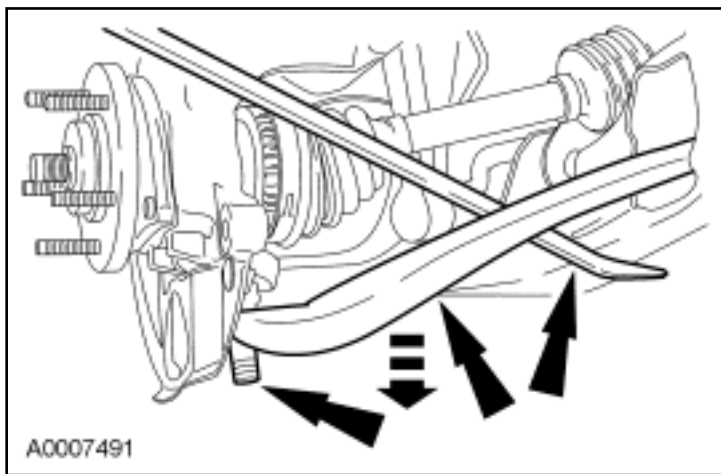

6. Install a new nut.

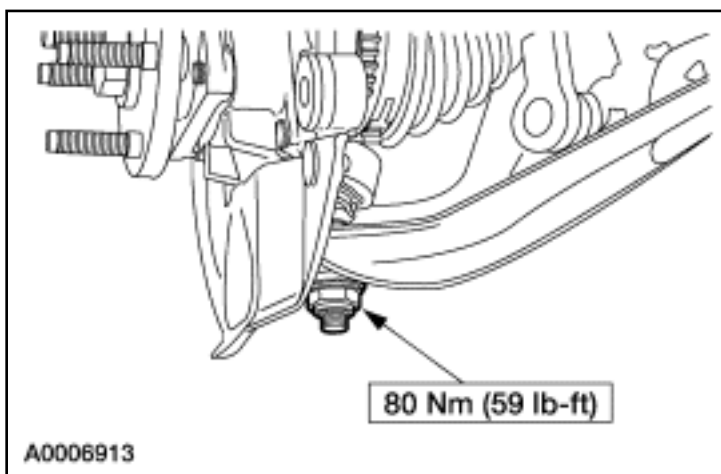

7. Install a new nut.

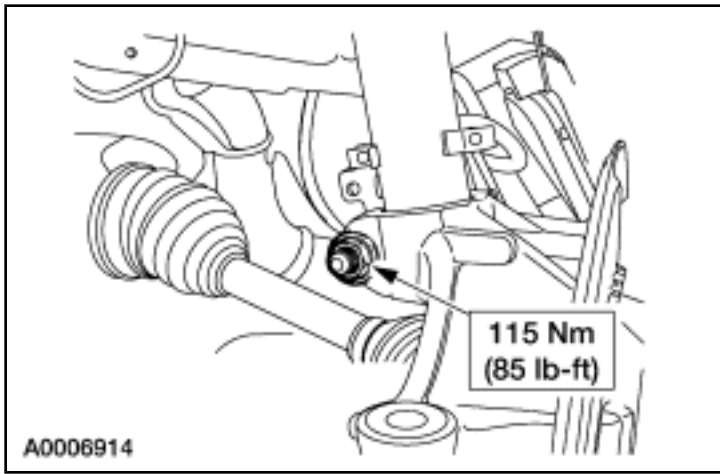

Vehicles equipped with ABS

8. Attach the ABS sensor wire retainer.

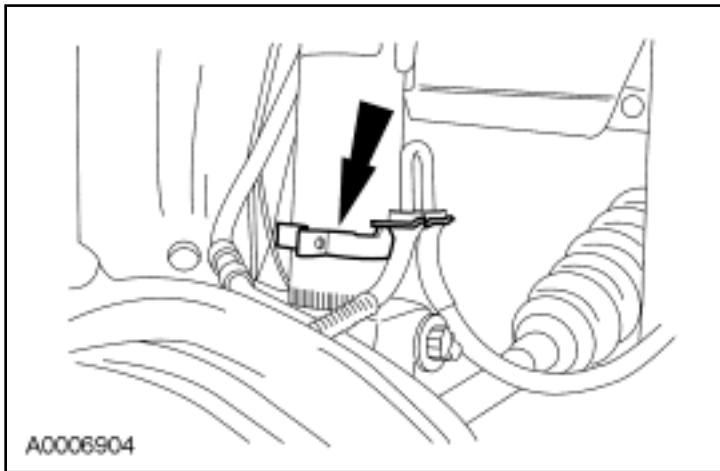

9. **NOTE:** Make sure the ABS sensor mounting hole does not have debris or corrosion build up, or false ABS activation can occur.

Position the ABS sensor and install the bolt.

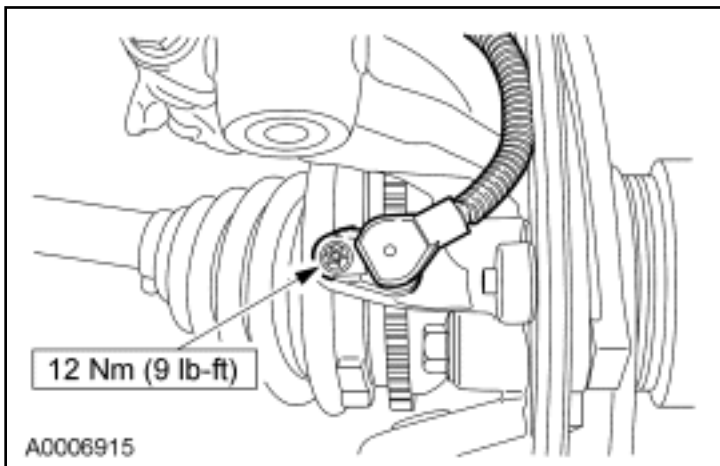

All vehicles

10. **NOTE:** If the hole in the tie-rod end does not line up with the slots in the nut, continue tightening the nut. Do not loosen the nut to align the slots in the nut with the hole in the outer tie-rod end.

Connect the tie-rod end to the knuckle and install a new nut and cotter pin.

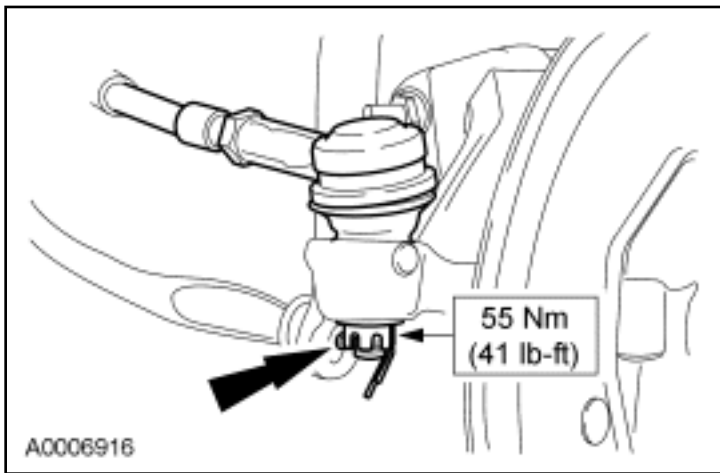

11. Install the brake disc. For additional information, refer to [Section 206-03](#).
12.  **CAUTION:** The front axle wheel hub retainer must be tightened to specification immediately during installation. If the retainer is not tightened immediately, the nylon lock will set incorrectly, leading to incorrect torque readings and bearing failure. Any front wheel hub retainer that is not immediately tightened to specification or is loosened must be removed and a new retainer installed.

Install the washer, the wheel hub retainer and the hub cap or wheel cover.

