

Select Vehicle | New TSBs | Technician's Reference

Component Search:

OK

Conversion Calculator

### 1997 Ford Truck F 150 2WD Pickup V8-5.4L SOHC VIN L

Vehicle Level → Engine, Cooling and Exhaust → Engine → Timing Chain → Service and Repair  
→ Installation ←

## Installation

[Notes](#)

**NOTE:** Ford does not provide a procedure to align the [timing components](#) without the OE tools specified.

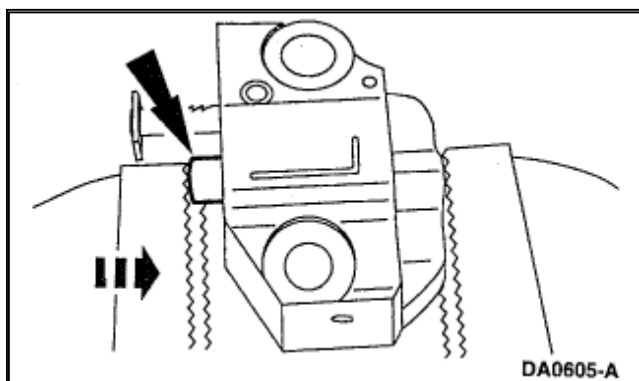

Zoom

Sized for Print

1. Compress the tensioner plunger, using an edge of a vise. **CAUTION:** Timing chain procedures must be followed exactly or damage to valves and pistons will result. Do not compress the ratchet assembly. This will damage the ratchet assembly.

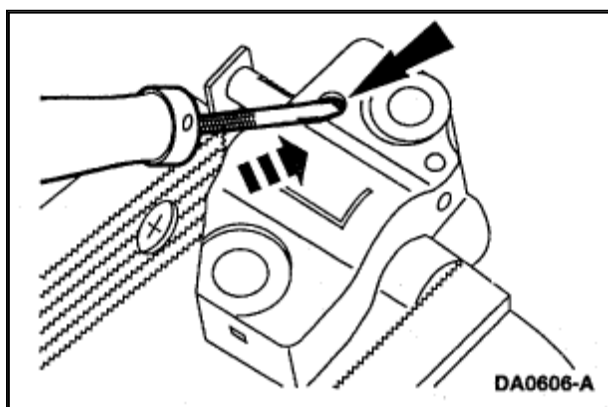

Zoom

Sized for Print

2. Use a small screwdriver or pick to push back and hold the ratchet mechanism.

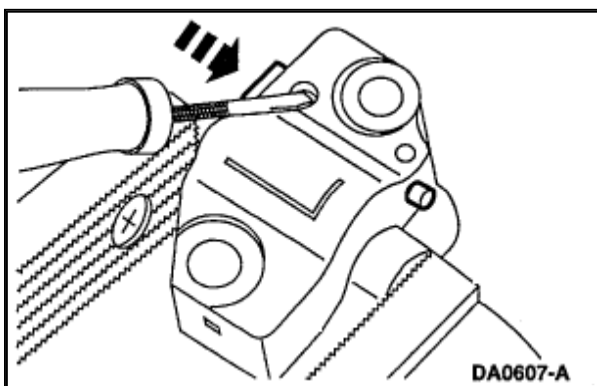

Zoom

Sized for Print

3. While holding the ratchet mechanism, push the ratchet arm back into the tensioner housing.

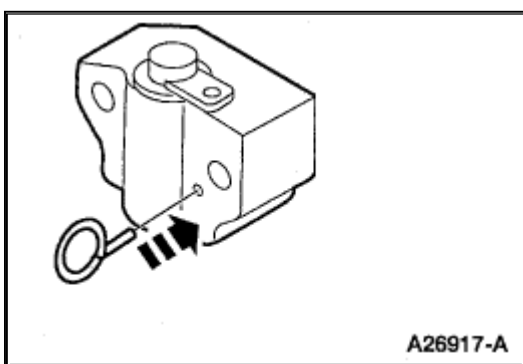

Zoom

Sized for Print

4. Install a paper clip into the hole in the tensioner housing to hold the ratchet assembly and plunger in during installation.
5. Remove the tensioner from the vise.

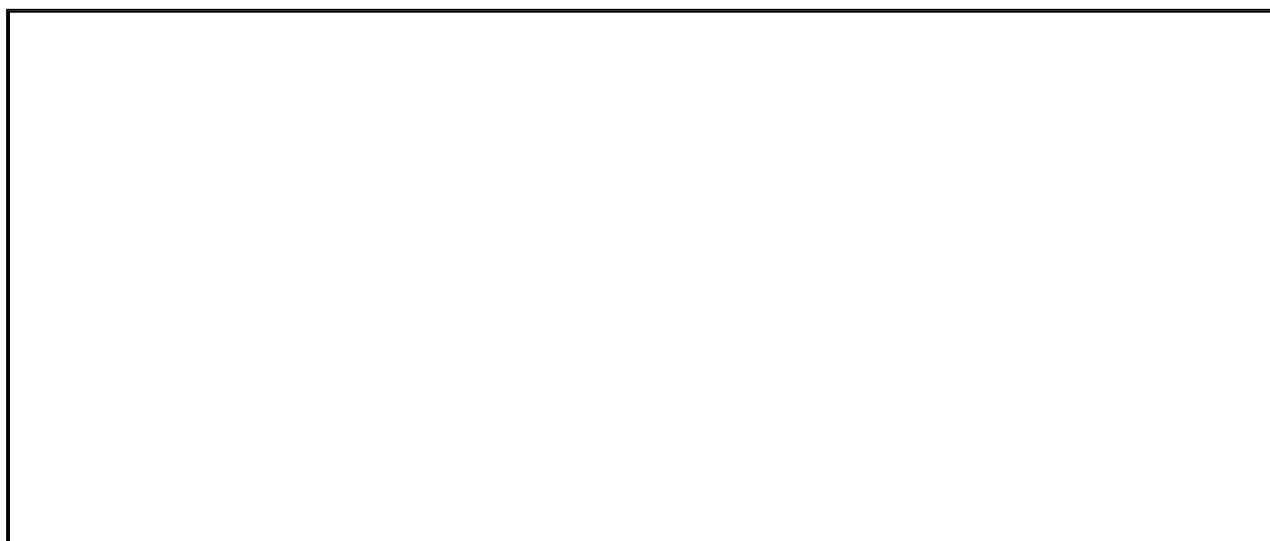

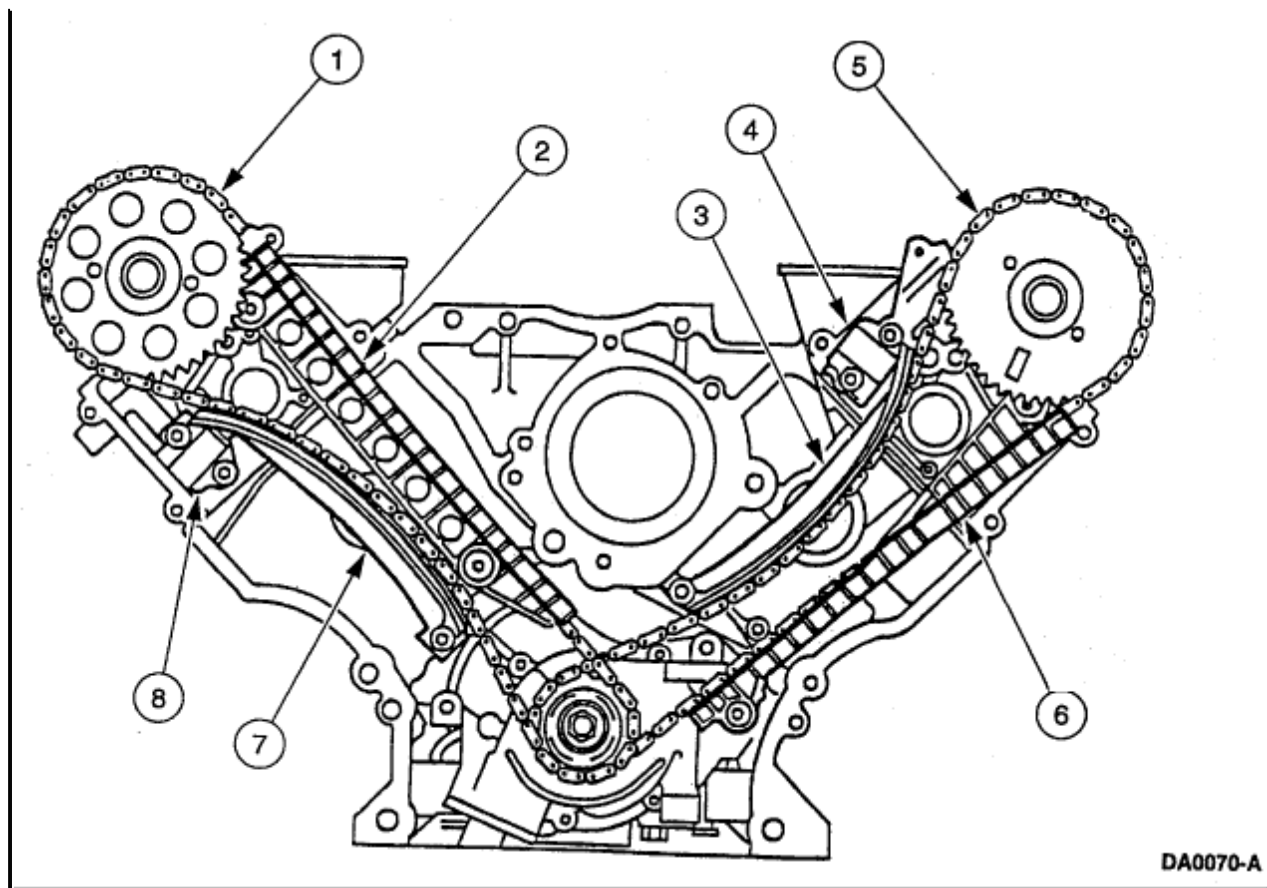

DA0070-A

Zoom

Sized for Print

Item	Part Number	Description
1	6288	Timing Chain (RH)
2	6M256	Timing Chain Guide (RH)
3	6M274	Timing Chain Tensioner Arm (LH)
4	6M269	Timing Chain Tensioner (LH)
5	6268	Timing Chain (LH)
6	6B274	Timing Chain Guide (LH)
7	6L253	Timing Chain Tensioner Arm (RH)
8	6L266	Timing Chain Tensioner (RH)

Zoom

Sized for Print

6. Check the illustrated components for part number orientation.



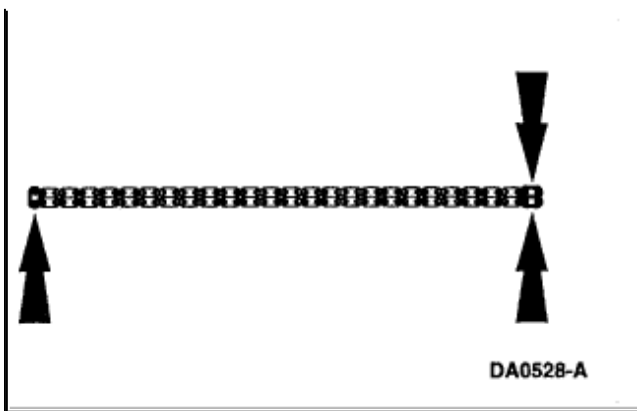

Zoom

Sized for Print

7. If the copper links are not visible, mark two links on one end and one link on the other end, and use as timing marks.

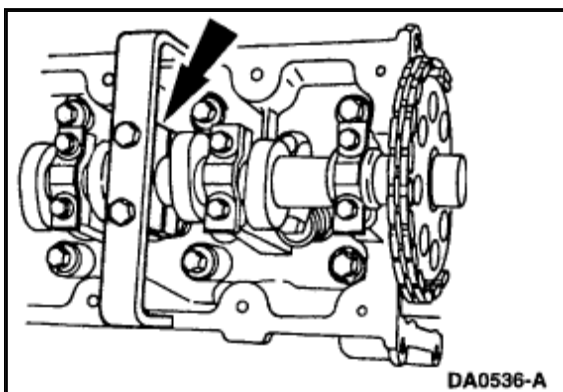

Zoom

Sized for Print

8. Loosely install the [Camshaft](#) Holding Tools on both camshafts.



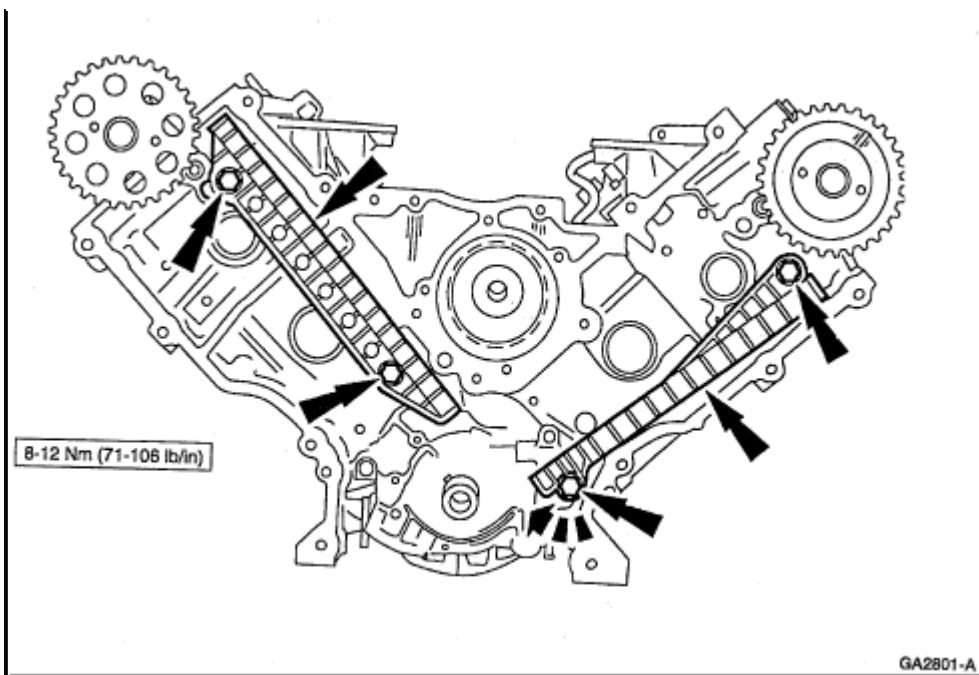

Zoom

Sized for Print

9. Install the [timing chain guides](#).

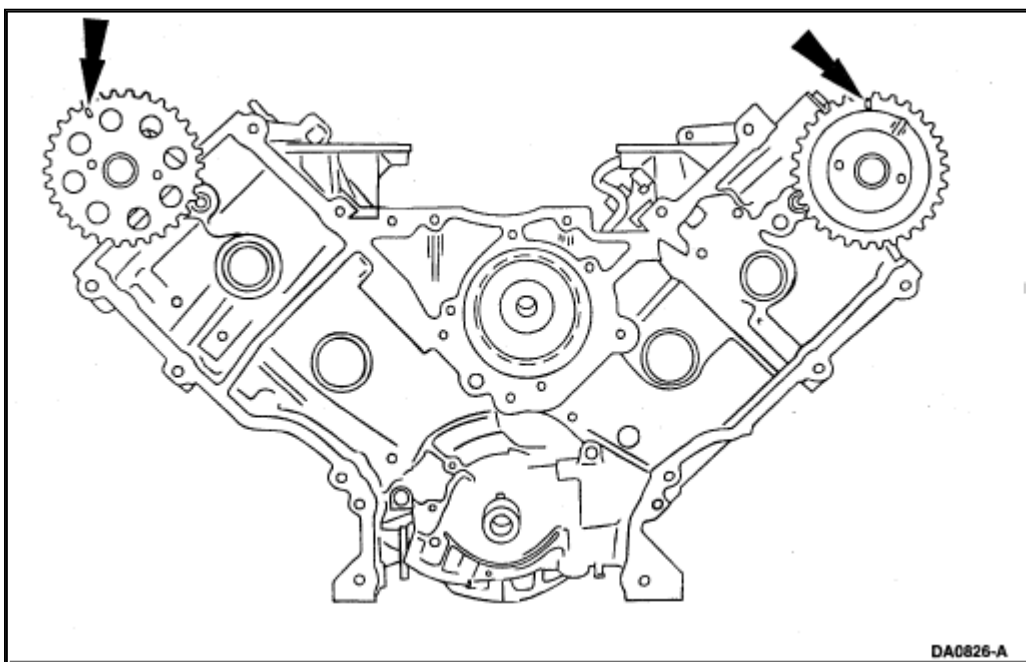

Zoom

Sized for Print

10. Rotate the LH [camshaft](#) with the Camshaft Positioning Tool until the timing mark is approximately at 12 o'clock. Rotate the RH [camshaft](#) with the Camshaft Positioning Tool until the timing mark is approximately at 11 o'clock. Tighten the Camshaft

Holding Tools to maintain camshaft pre-positioning.

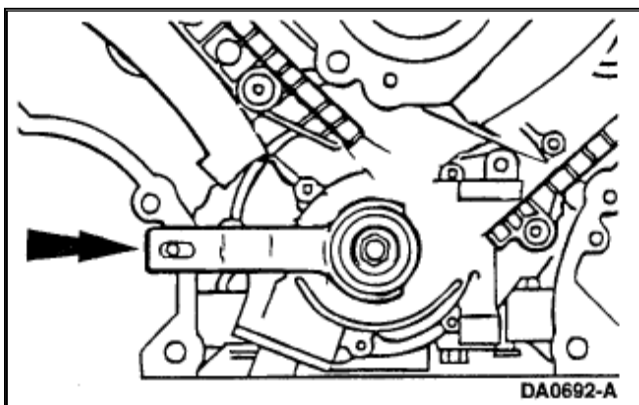

Zoom

Sized for Print

11. Position the [crankshaft](#) with the Crankshaft Holding Tool. **CAUTION:** Unless otherwise instructed, at no time when the timing chains are removed and the cylinder heads are installed is the [crankshaft](#) or [camshaft](#) to be rotated. Severe [piston](#) and valve damage will occur. Rotate the crankshaft counterclockwise only. Do not rotate past position shown or severe piston and/or valve damage can occur.
12. Remove the [Crankshaft](#) Holding Tool.

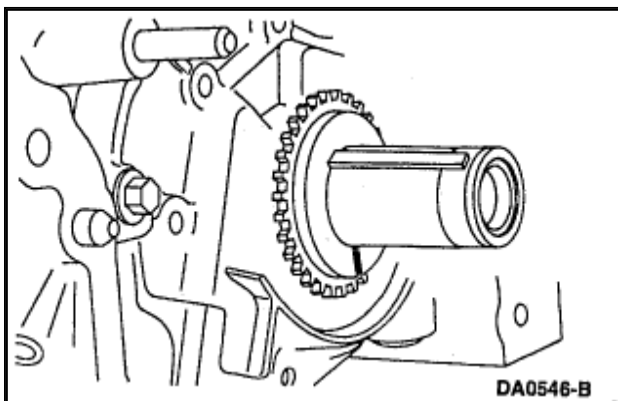

Zoom

Sized for Print

Fig. 26 Crankshaft Sprocket Position

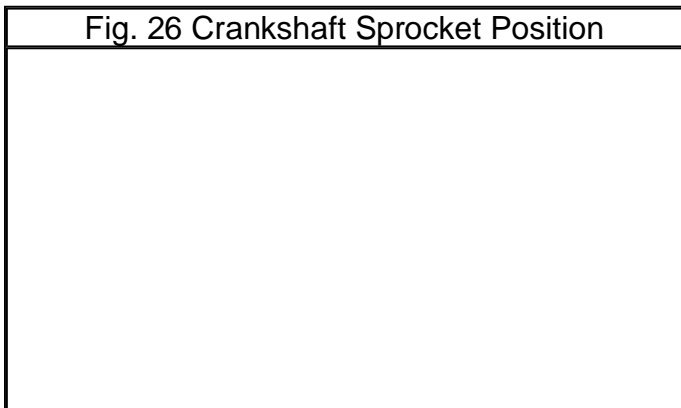

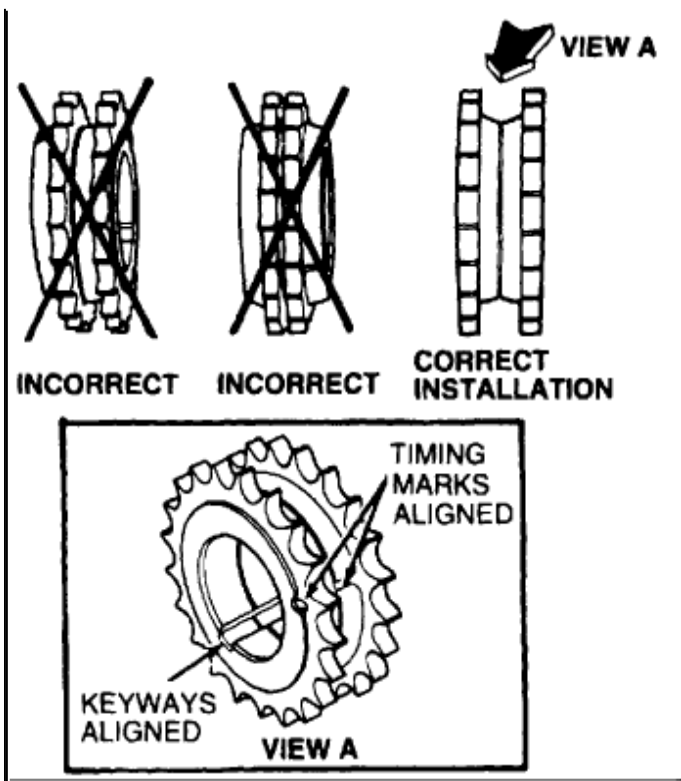

Zoom

Sized for Print

13. Position the inner crankshaft sprocket with the long hub facing outward.

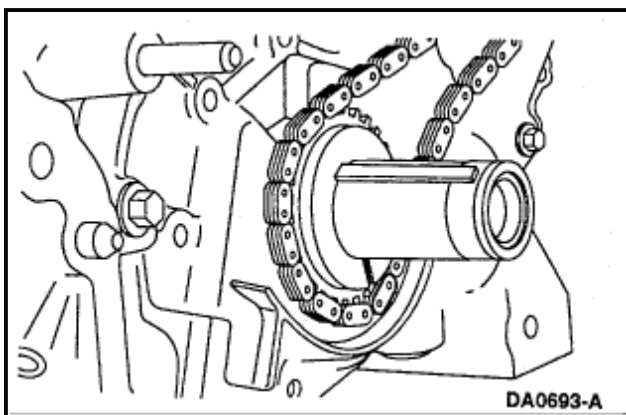

Zoom

Sized for Print

14. Install the LH timing chain onto the crankshaft sprocket, aligning the one copper link on the timing chain with the slot on the crankshaft sprocket.



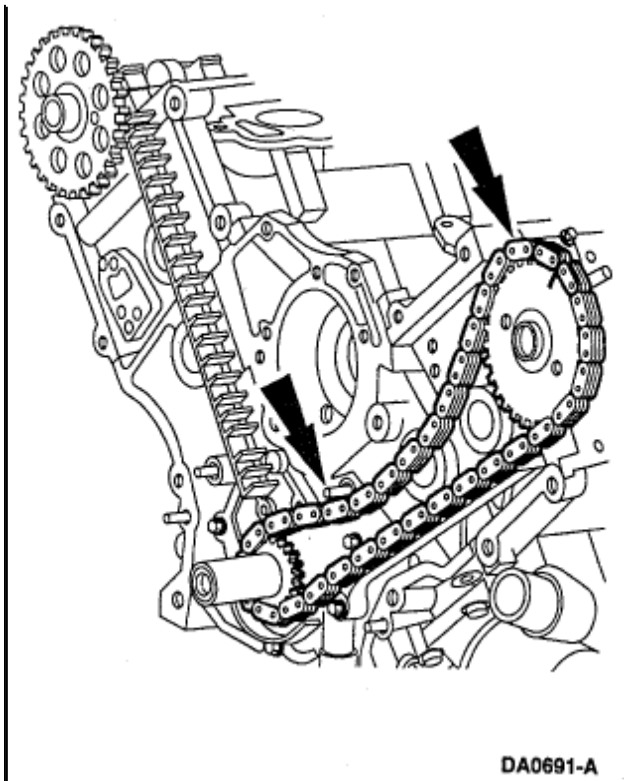

Zoom

Sized for Print

15. Position the timing chain on the camshaft sprocket with the two copper chain links and the camshaft sprocket timing mark aligned. **NOTE:** Make sure the upper half of the chain is below the tensioner guide dowel. If necessary, use the [Camshaft Positioning Tool](#) to adjust. If necessary, adjust the camshaft sprocket slightly to obtain timing mark alignment.



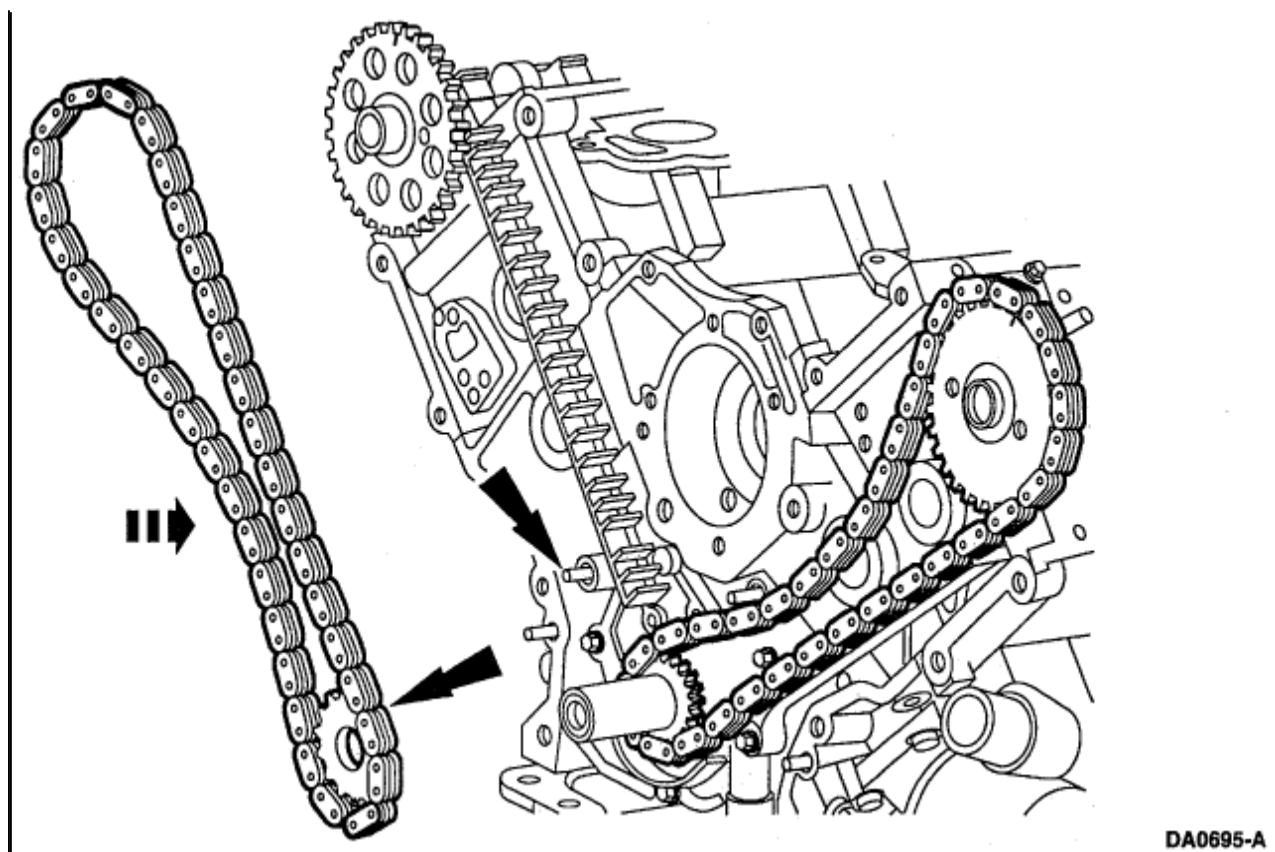

Zoom

Sized for Print

16. Position the outer camshaft sprocket and the RH timing chain with the long hub of the sprocket facing inward. **CAUTION:** The camshaft sprocket can jump time if the [Camshaft Holding Tool](#) is not secured. **NOTE:** Be sure the copper chain link and crankshaft sprocket timing mark are aligned. The lower half of the timing chain must be positioned above the dowel.
17. Position the RH timing chain on the camshaft sprocket. Make sure the two copper-colored links align with the camshaft sprocket timing mark. **NOTE:** If necessary, adjust the camshaft sprocket slightly to obtain timing mark alignment.

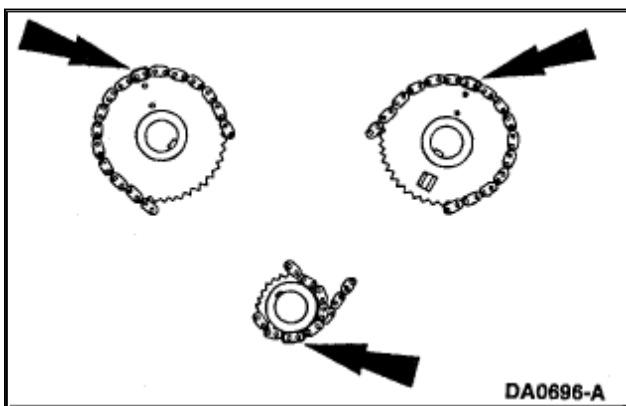

Zoom

Sized for Print

18. As a post-check, verify proper alignment of all timing marks.

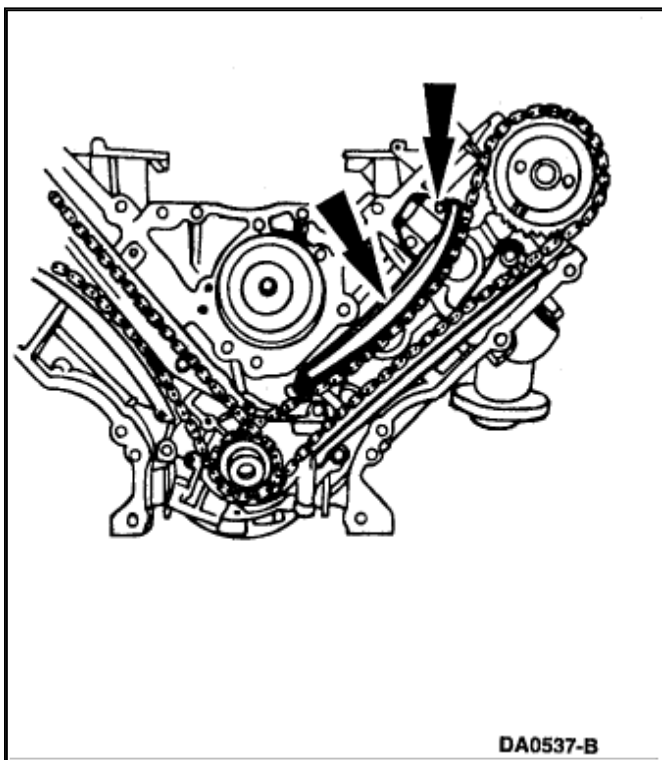

DA0537-B

Zoom

Sized for Print

19. Position the LH and RH [timing chain tensioner](#) guides on the dowel pins. Position the timing chain tensioner assemblies, and install the timing chain tensioner bolts.

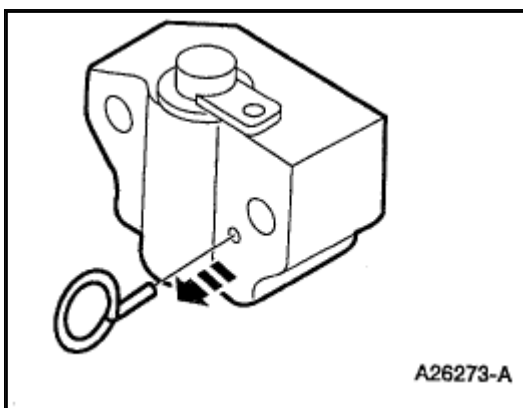

A26273-A

Zoom

Sized for Print

20. Remove both the RH and LH retaining pins from the [timing chain tensioner](#) assembly.



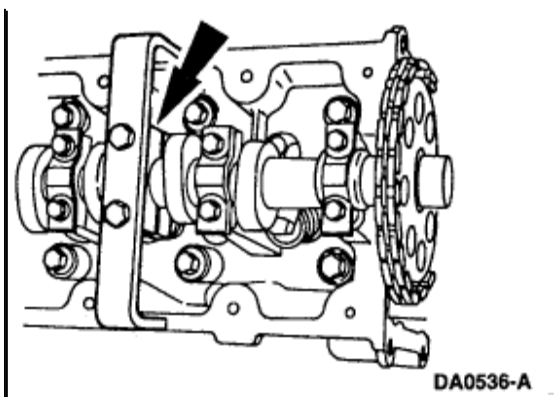

Zoom

Sized for Print

21. Remove the [Camshaft](#) Holding Tools from the camshafts.

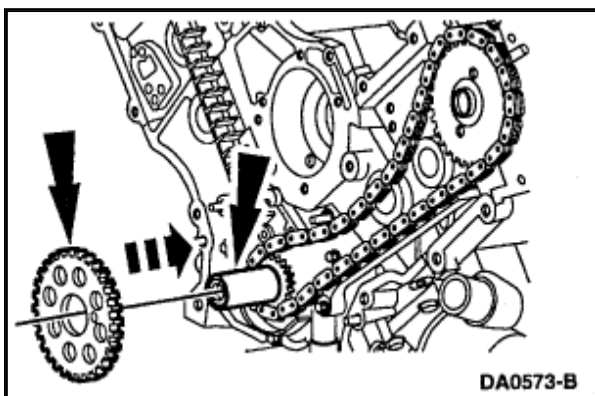

Zoom

Sized for Print

22. Position the crankshaft sensor ring on the [crankshaft](#).

23. Install the engine front cover.