

1. Disconnect negative battery cable from jumper terminal. Raise and support vehicle. Remove right front wheel. Remove accessory drive belt splash shield from right wheelwell.
2. Remove accessory drive belts. Remove right engine support assembly vertical bolts from bottom side of frame rail (timing belt end of engine).
3. Lower vehicle. Place floor jack under vehicle to support weight of engine and transaxle assembly. Remove 3 bolts attaching engine support assembly to engine block bracket.
4. Move the A/C drier aside with hoses attached. Remove coolant reservoir tank. Remove right engine support assembly. Remove 3 bolts attaching engine support bracket to engine block, and remove bracket.
5. Remove crankshaft vibration damper. Remove power steering pump (hoses attached) and bracket from engine block. Remove timing belt covers.
6. Rotate crankshaft to align camshaft and crankshaft timing marks. See **Fig. 11** and **Fig. 12**.

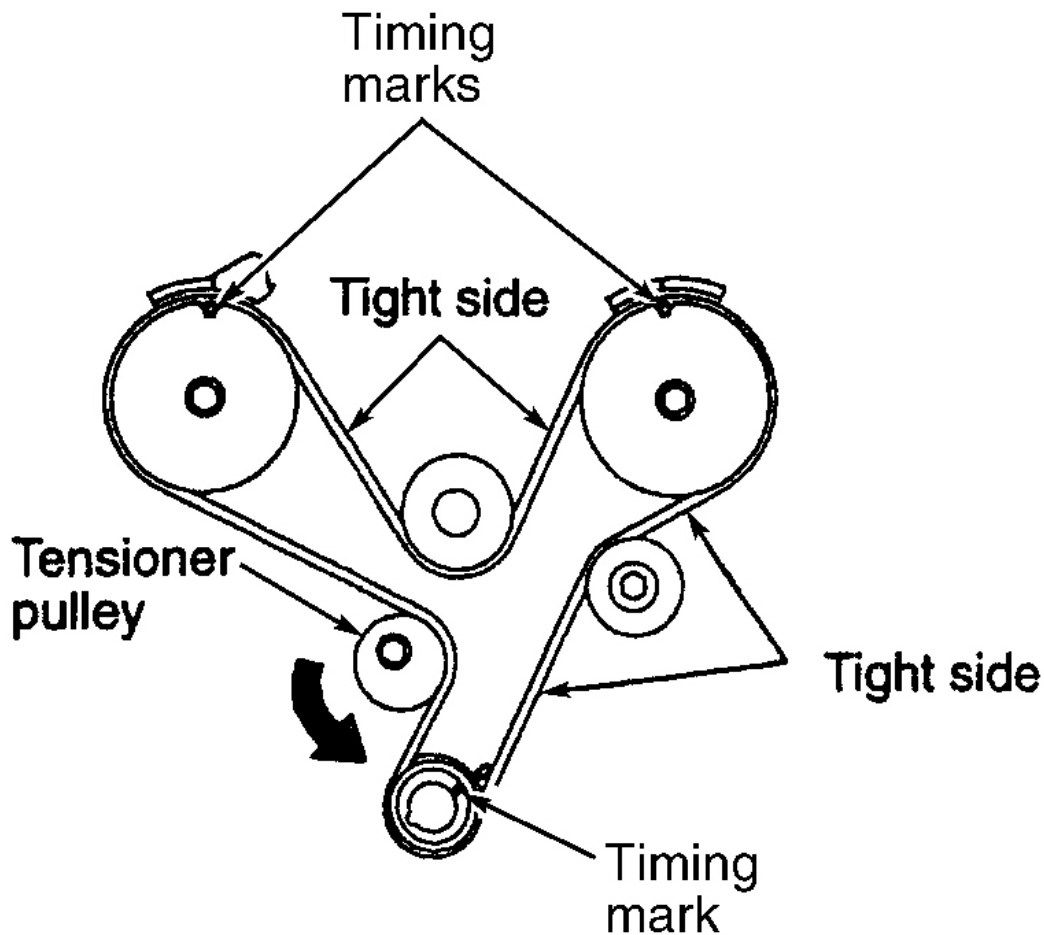

G00078714

**Fig. 11: Aligning Crankshaft & Camshaft Timing Marks**

Courtesy of DAIMLERCHRYSLER CORP.

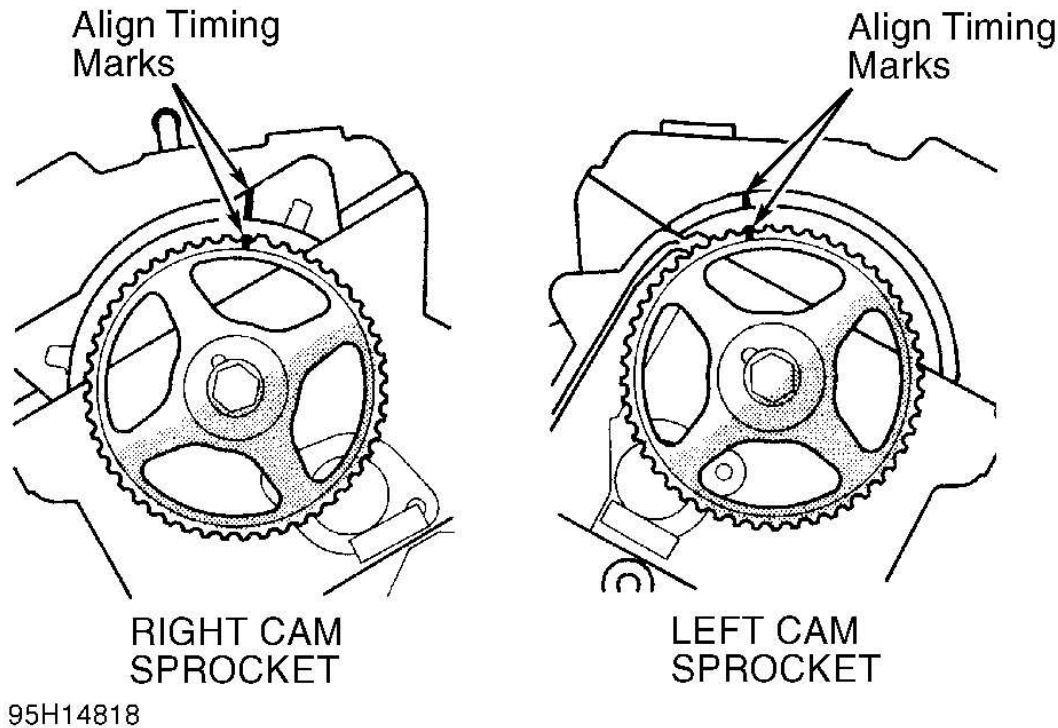

**Fig. 12: Aligning Camshaft Sprockets**  
 Courtesy of CHRYSLER CORP.

7. If reusing old timing belt, mark timing belt direction of rotation for installation reference. Loosen timing belt automatic tensioner bolts. Remove timing belt. Remove automatic tensioner.

**CAUTION: DO NOT rotate crankshaft or camshaft with timing belt removed.**

**NOTE:** When automatic tensioner is removed from engine, it is necessary to compress plunger into tensioner body.

#### Installation 2.5L VIN H (Cirrus, Sebring Convertible & Stratus)

1. Place automatic tensioner into vise, and SLOWLY compress plunger. When plunger is compressed into tensioner body, install locking pin through body and plunger holes to retain plunger until tensioner is installed. See **Fig. 13**.
2. Index tensioner in vise the same direction as installed. This will ensure proper pin orientation when tensioner is installed in engine. See **Fig. 13**.

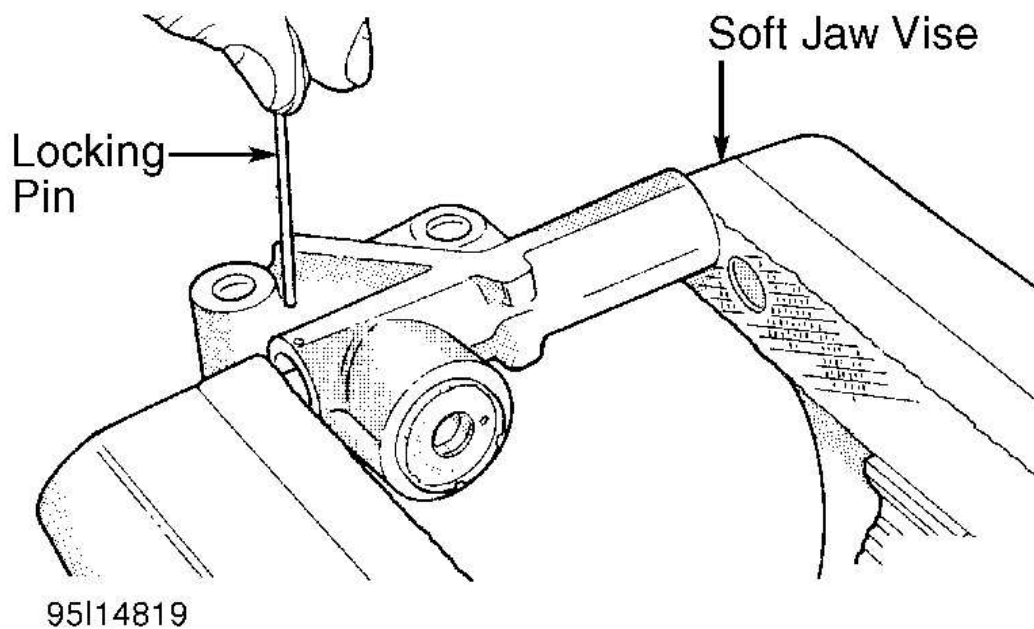

**Fig. 13: Compressing Tensioner**  
Courtesy of CHRYSLER CORP.

3. Align crankshaft mark with timing mark on oil pump housing, then back off 3 notches before TDC. See **Fig. 14**. This will position the crankshaft for timing belt installation. Set camshaft sprockets by aligning timing marks on sprockets with marks on rear timing belt cover. See **Fig. 15**.

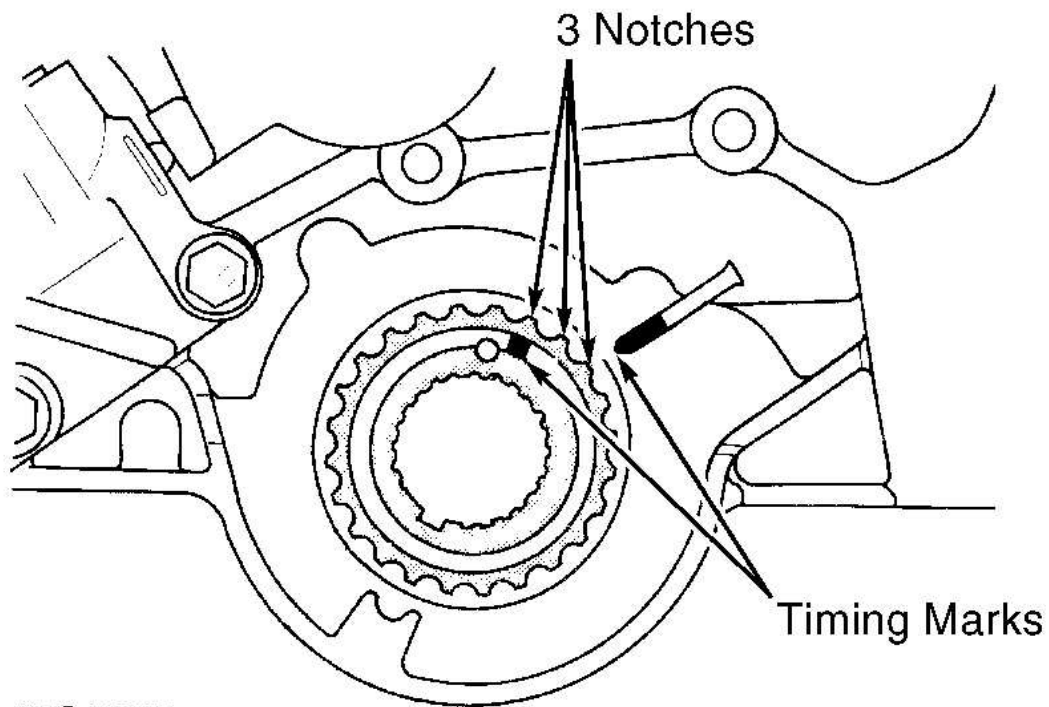

95G14817

**Fig. 14: Crankshaft Sprocket - Timing Belt Installation Position (This Is Not TDC Checking Position)**  
Courtesy of CHRYSLER CORP.

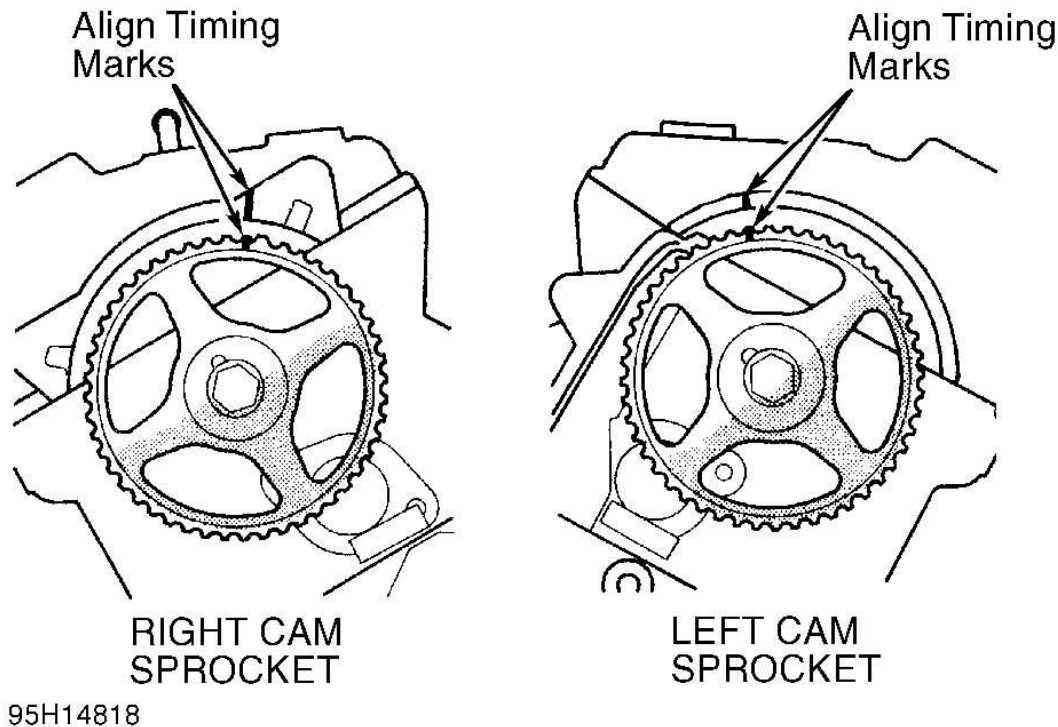
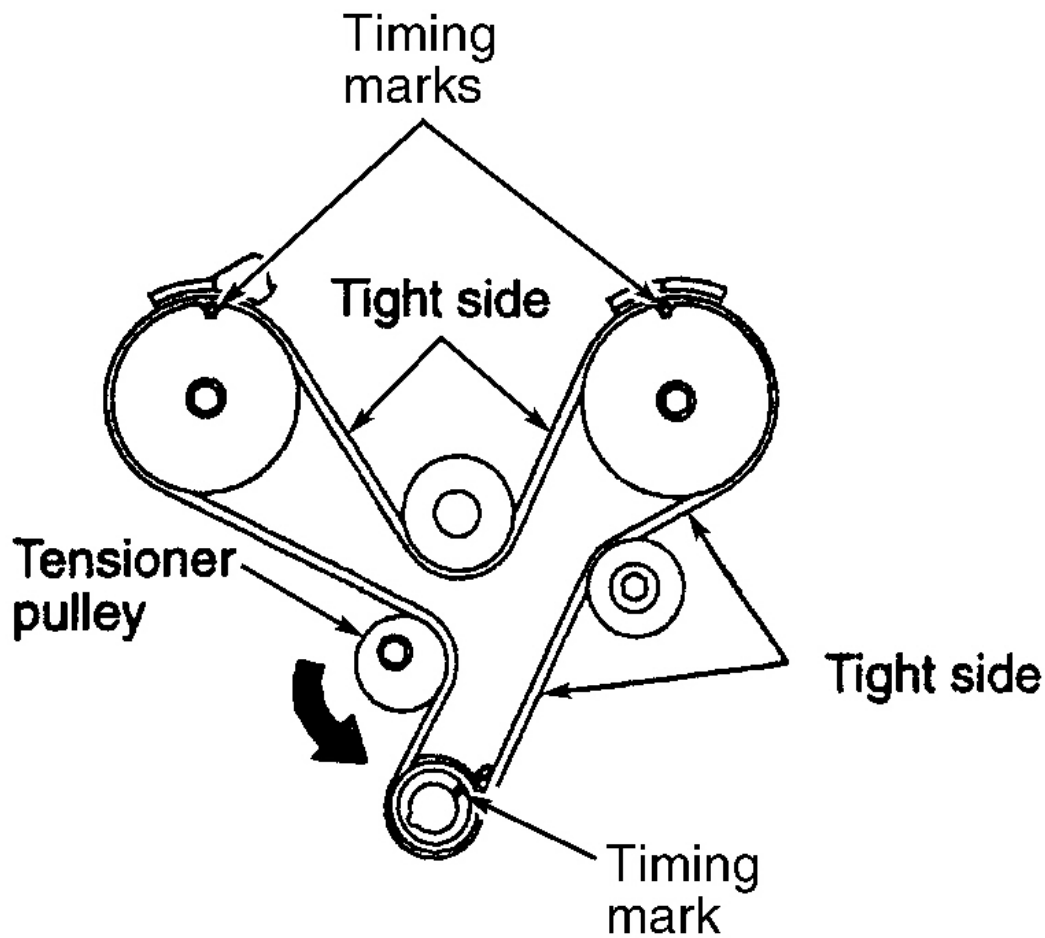

**Fig. 15: Aligning Camshaft Sprockets**  
Courtesy of CHRYSLER CORP.

**NOTE:** If reusing old timing belt, install in original direction of rotation.

4. Install timing belt on right (next to firewall) camshaft sprocket first. Install a spring clip to keep belt in position. Keeping belt taut, install belt under water pump pulley and then around front camshaft sprocket. Install spring clip on front sprocket and belt.
5. Rotate crankshaft clockwise to TDC position. This will take the installation slack out of the timing belt and align the crankshaft timing marks to the TDC position. Continue routing belt around idler pulley, crankshaft sprocket, and tensioner pulley. Apply rotating force to crankshaft sprocket in clockwise direction to tension belt. Ensure camshaft timing marks and crankshaft TDC timing marks are aligned. See **Fig. 16**.

**CAUTION:** Ensure crankshaft has been rotated clockwise from the timing belt installation position to remove slack from timing belt and crankshaft timing marks are **ALIGNED**.



G00078714

**Fig. 16: Aligning Crankshaft & Camshaft Timing Marks After Removing Slack From Timing Belt**  
 Courtesy of DAIMLERCHRYSLER CORP.

6. Loosen tensioner pulley center bolt. Position tensioner pulley with pin holes facing down. Install Adapter (MD998767) or equivalent, and torque wrench, to tensioner pulley. See **Fig. 17**. Apply 39 INCH lbs. (4.4 N.m) in a counterclockwise direction to tensioner. Tighten tensioner bolt to specification, without letting tensioner pulley rotate.
7. With torque being applied to tensioner pulley, install automatic tensioner (with locking pin in place) to tensioner pulley bracket. Tighten bolts to specification. See **TORQUE SPECIFICATIONS**. Pull tensioner plunger locking pin.

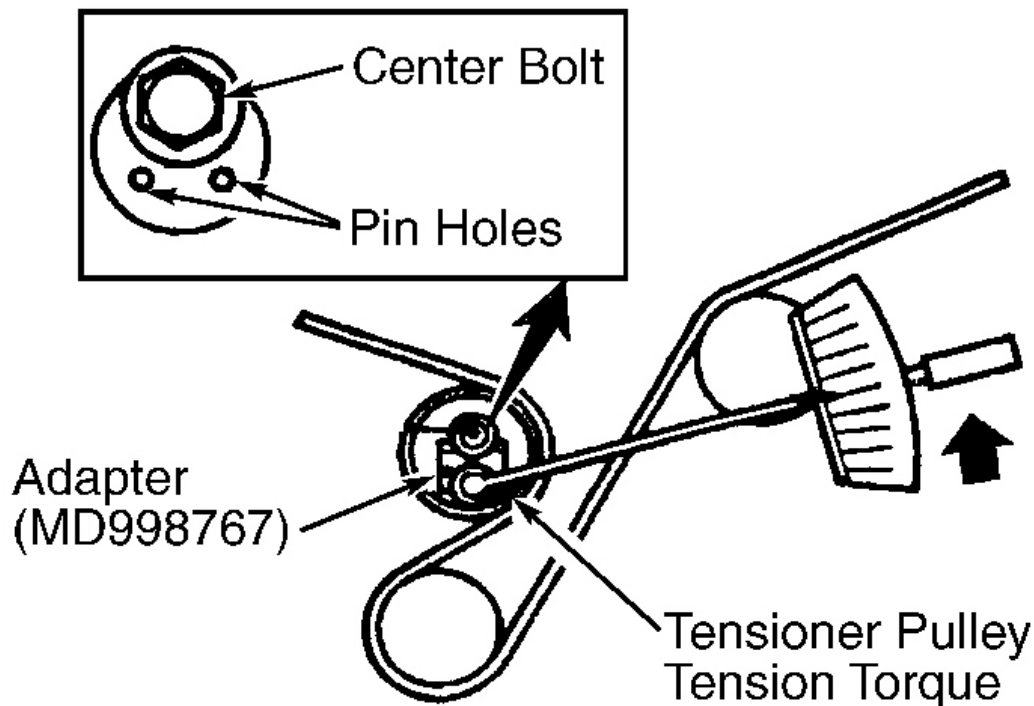

G99I54117

**Fig. 17: Tensioning Timing Belt**  
 Courtesy of DAIMLERCHRYSLER CORP.

8. Rotate crankshaft 2 revolutions clockwise, and check alignment of timing marks. Install tensioner locking pin into automatic tensioner. Pin should slide in and out with no resistance. Even if locking pin cannot be easily inserted, belt tension is okay if automatic tensioner plunger projection is within .149-.177" (3.8-4.5 mm). Projection is measured between top edge of automatic tensioner housing and arm of tensioner pulley bracket. Retension timing belt, if necessary.
9. Install timing belt covers. Install crankshaft vibration damper. Tighten crankshaft damper bolt to specification. See **TORQUE SPECIFICATIONS**.
10. On all models, reverse removal procedure to complete installation. Adjust drive belts to proper tension. See appropriate COOLING SYSTEM SPECIFICATIONS article in ENGINE COOLING.

## TORQUE SPECIFICATIONS

### TORQUE SPECIFICATIONS

Application	Ft. Lbs. (N.m)
Camshaft Sprocket Bolt	65 (88)

many waters gallery

Wednesday, April 15, 2009 4:13:49 PM

Page 7

© 2005 Mitchell Repair Information Company, LLC.

## 1997 Chrysler Sebring JXi

1995-2000 TIMING BELT Chrysler 2.5L V6 (VIN H & N)

Crankshaft Vibration Damper Bolt	134 (182)
Engine Mount Bracket-To-Engine Block	
Cirrus, Sebring Convertible & Stratus	33 (45)
Engine Mount-To-Engine Support Bracket Bolt/Nut	
Avenger & Sebring Coupe	64 (86)
Engine Mount-To-Frame Through-Bolt	
Avenger & Sebring Coupe	72-87 (98-118)
Engine Support Assembly-To-Engine Mount Bracket	
Avenger & Sebring Coupe	47-54 (64-74)
Cirrus, Sebring Convertible & Stratus	45 (61)
Engine Support Assembly-To-Frame Rail	
Avenger & Sebring Coupe	47-54 (64-74)
Cirrus, Sebring Convertible & Stratus	45 (61)
Engine Support Bracket-To-Engine Block Bolt	
Avenger & Sebring Coupe	47-54 (64-74)
Generator Mount Bracket-To-Engine Block	
Avenger & Sebring Coupe	30 (41)
Power Steering Pump Bracket-To-Engine Bolts	
Avenger & Sebring Coupe	16 (22)
Cirrus, Sebring Convertible & Stratus	40 (54)
Timing Belt Idler Pulley Bolt	32 (44)
Timing Belt Tensioner Pivot Arm Bolt	33 (45)
Timing Belt Tensioner Pulley Bolt	35 (48)
Timing Belt Tensioner-To-Engine Bolt	17 (23)
Water Pump Bolt	18 (24)
Wheel Lug Nut	
Avenger & Sebring Coupe	65-80 (88-108)
Cirrus, Sebring Convertible & Stratus	100 (135)
	<b>INCH Lbs. (N.m)</b>
Timing Belt Cover Bolts	89-106 (10-12)