

REAR ABSORBER

REMOVAL

1. Remove rear fascia, refer to (Refer to **REAR FASCIA**).
2. Remove rivets attaching absorber to rear crossmember (**Fig. 6**).
3. Separate absorber from vehicle.

INSTALLATION

1. Position absorber on vehicle.
2. Install rivets attaching absorber to rear crossmember. (**Fig. 6**)
3. Install rear fascia, refer to (Refer to 13 - FRAMES & BUMPERS/BUMPERS/FRONT FASCIA - **INSTALLATION**).

REAR FASCIA

REMOVAL

1. Raise and support vehicle.
2. Remove wheels.
3. Remove plastic push pins attaching fascia to fuel tank skid plate.
4. Remove plastic rivets attaching fascia to wheel liner.
5. Remove nuts attaching upper edge of fascia to quarter panel and wheel liner (**Fig. 5**).

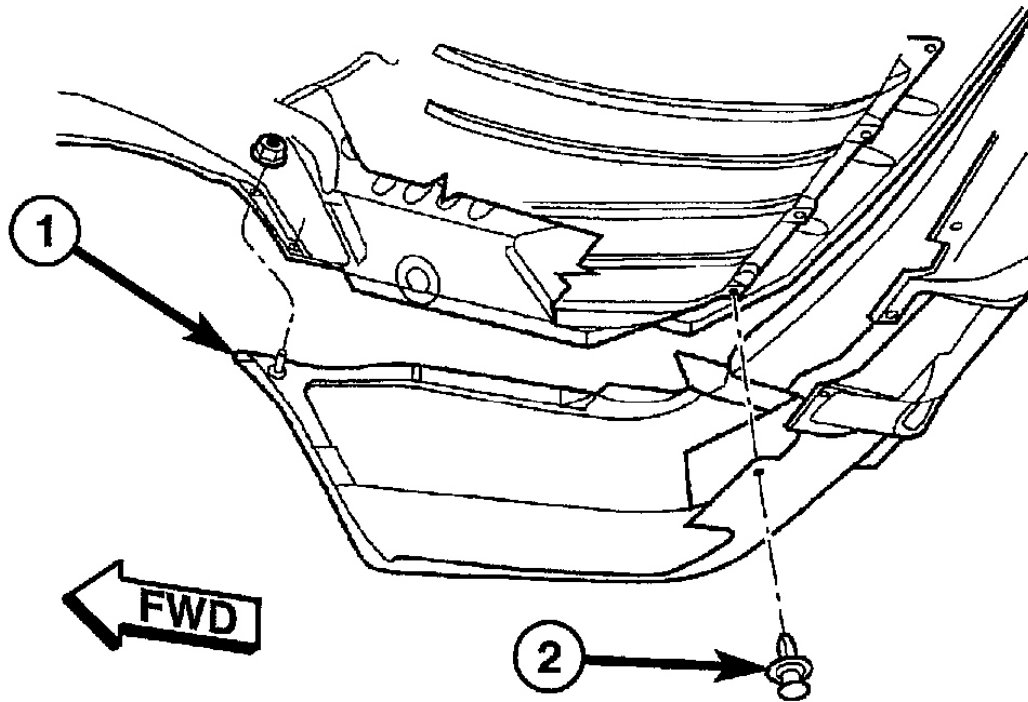

- 1 - FASCIA
- 2 - PLASTIC PUSH PIN

G03575084

Fig. 5: Removing Rear Fascia Attachment
Courtesy of DAIMLERCHRYSLER CORP.

6. Remove plastic push pins attaching fascia to liftgate opening (**Fig. 6**).

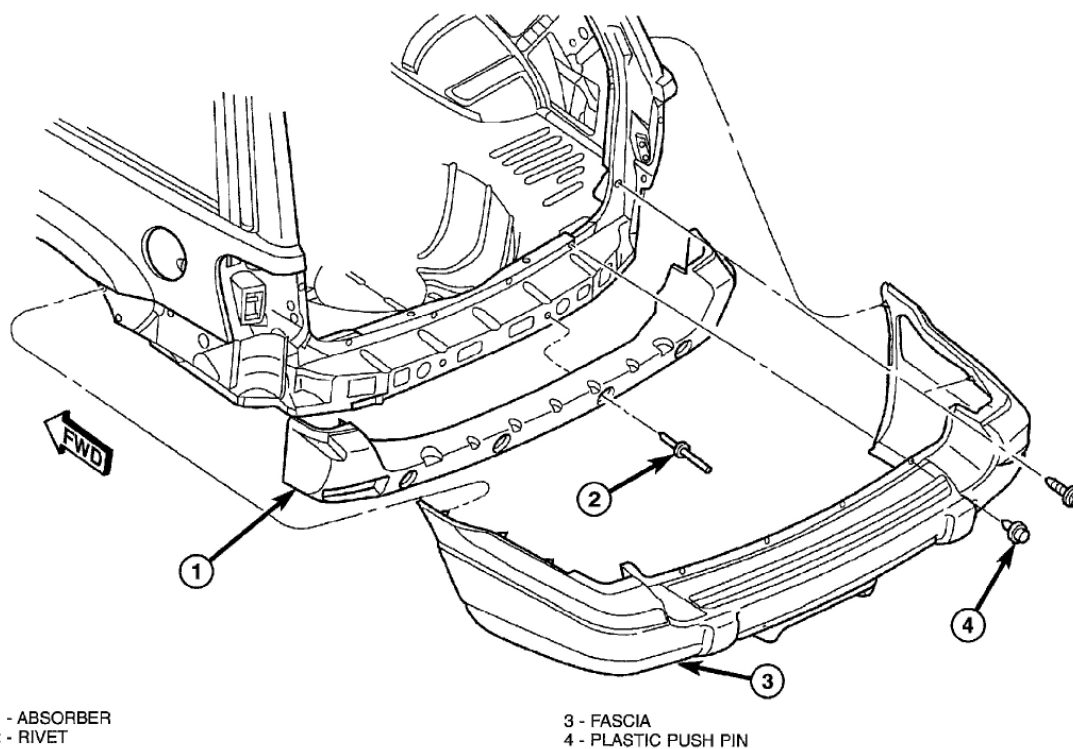
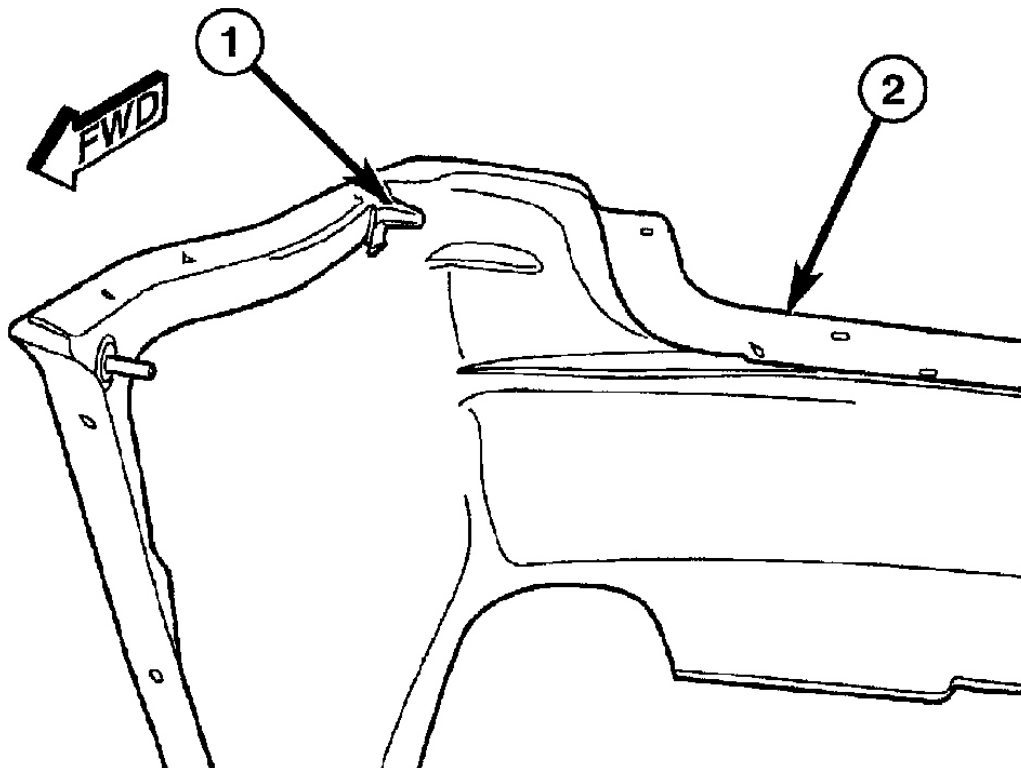

Fig. 6: Removing Rear Fascia
Courtesy of DAIMLERCHRYSLER CORP.

7. Remove screws attaching fascia to liftgate opening.
8. Remove D pillar trim and scuff plate outboard screws.
9. Remove the rearward tie down screws and the aperture trim panel.
10. Carefully peel back the rubber body sealer patch to access the retainer clips.
11. Release the forward and rearward retainer clips on both sides of the fascia.
12. Grasp forward edges of fascia and pull outward to disengage retainers attaching fascia to quarter panel (**Fig. 7**).



1 - RETAINER

2 - FASCIA

G03575086

Fig. 7: Removing Rear Fascia Retainers
Courtesy of DAIMLERCHRYSLER CORP.

13. Separate fascia from vehicle.

INSTALLATION

1. Position fascia on vehicle aligning retainers with slots in quarter panel (**Fig. 8**).

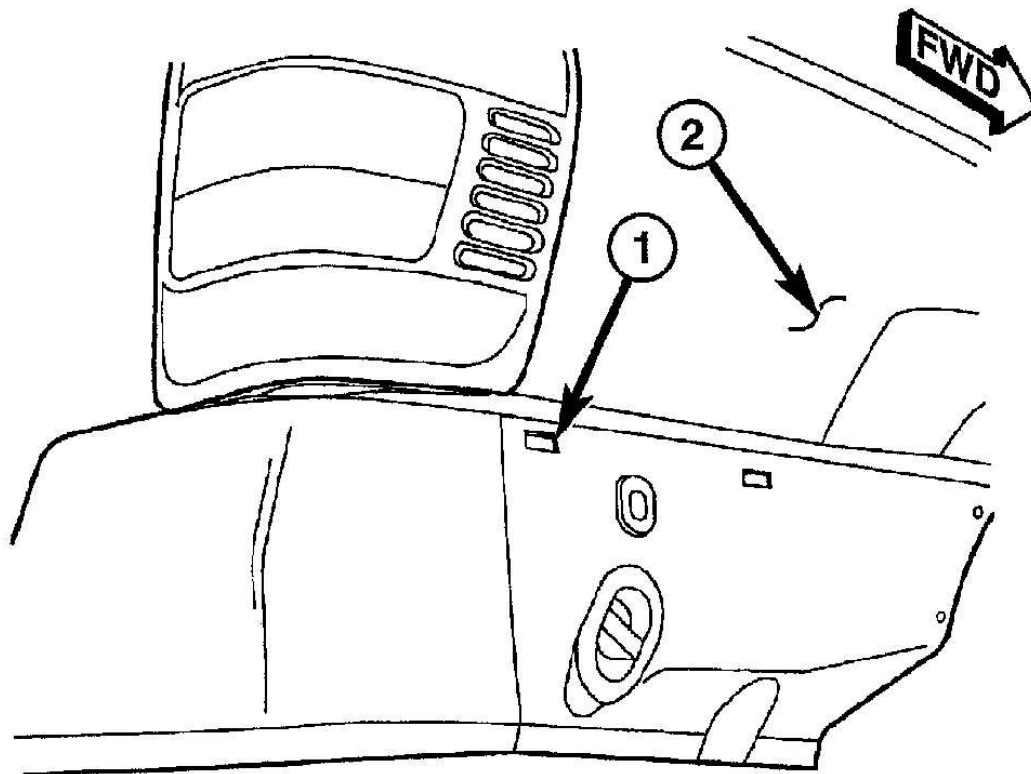

- 1 - SLOT
- 2 - QUARTER PANEL

G03575087

Fig. 8: Positioning Fascia Attachment
Courtesy of DAIMLERCHRYSLER CORP.

2. Press forward edges of fascia inward to engage retainers.
3. Install screws attaching fascia to liftgate opening.
4. Install plastic push pins attaching fascia to liftgate opening.
5. Install nuts attaching upper edge of fascia to quarter panel and wheel liner.
6. Install plastic rivets attaching fascia to wheel liner.
7. Install support lower vehicle.
8. Install plastic push pins attaching fascia to fuel tank skid plate.
9. Install the interior trim panels removed to access fascia retainers.
10. Install tie down loop screws.