

2006 Hyundai Tiburon GT

2006 TRANSMISSION Clutch System - Tiburon

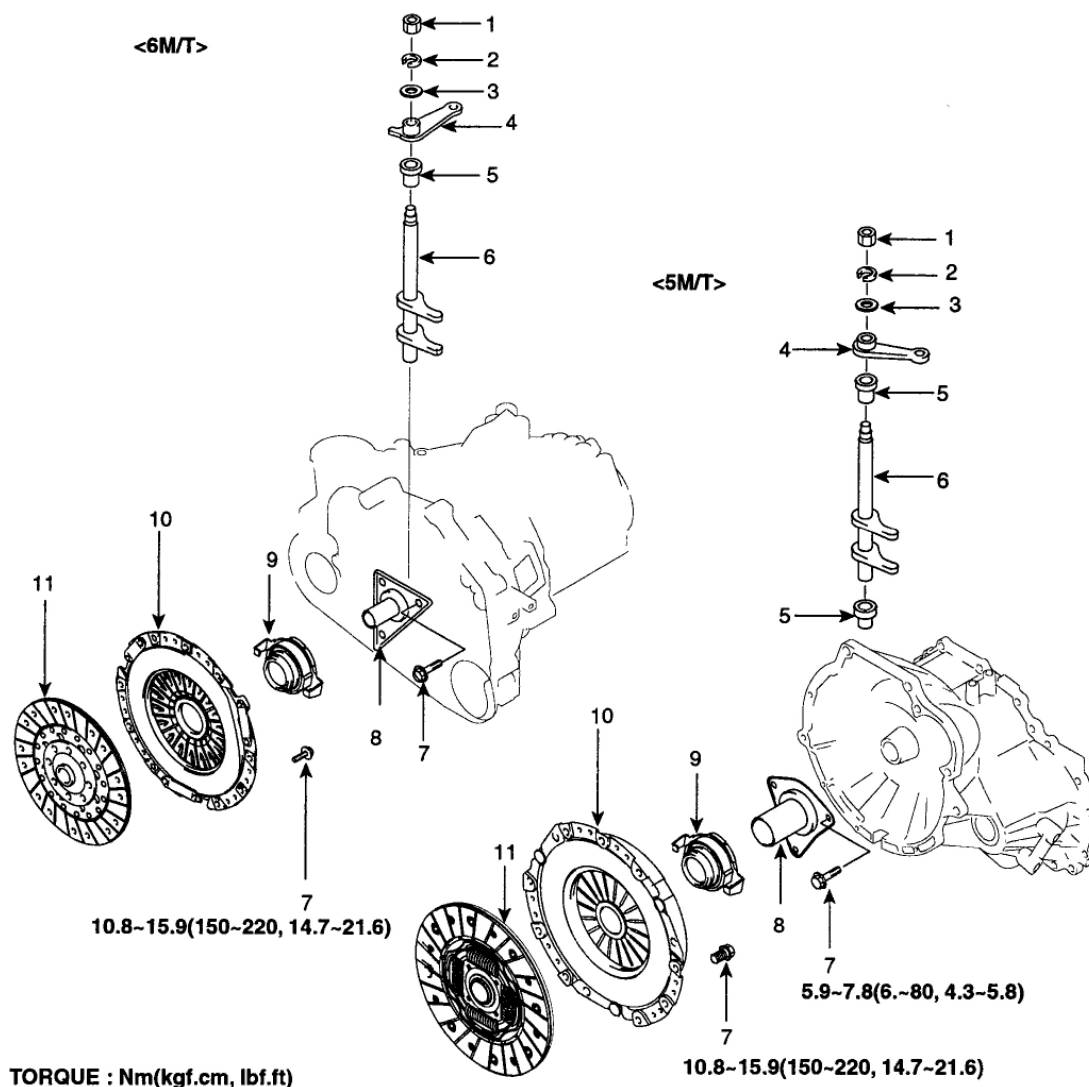

- 1. Nut
- 2. Spring washer
- 3. Plain washer
- 4. Release fork shaft lever
- 5. Bushing
- 6. Clutch release fork shaft

- 7. Bolt
- 8. Release bearing sleeve
- 9. Clutch release bearing
- 10. Clutch cover assembly
- 11. Clutch disc assembly

G03849632

Fig. 5: Identifying Clutch Cover & Disc Component With Torque Specifications
 Courtesy of HYUNDAI MOTOR CO.

REMOVAL

1. Drain the clutch fluid and transaxle gear oil.
2. Remove the transaxle assembly.
3. Insert the special tool (09411-25000) in the clutch disc to prevent the disc from falling.

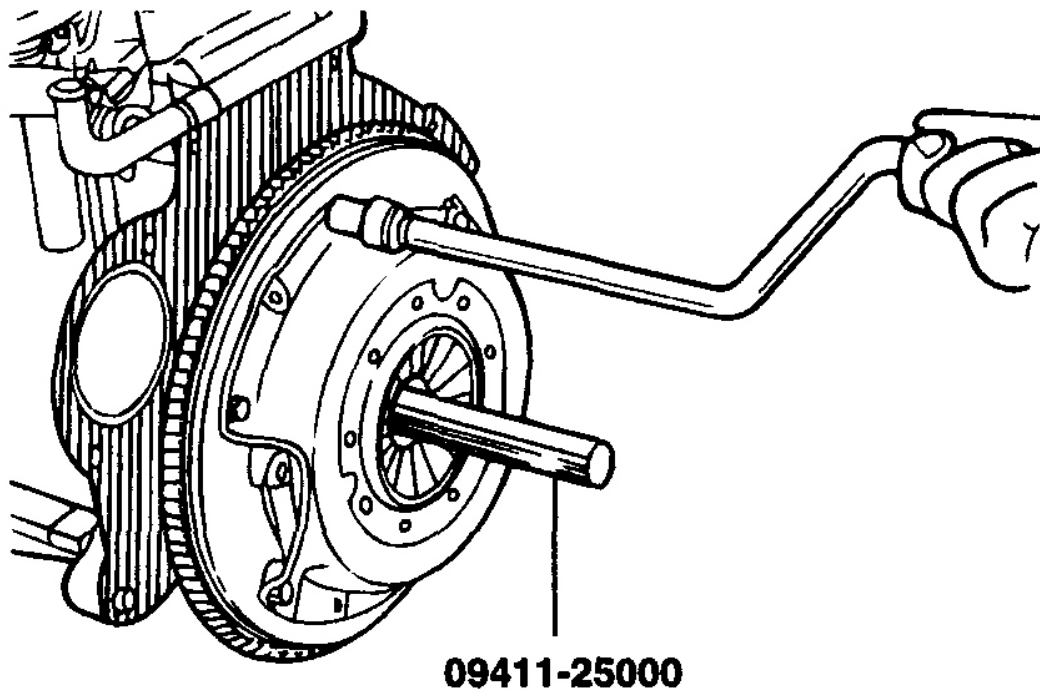

G03849633

Fig. 6: Inserting Special Tool In Clutch Disc
Courtesy of HYUNDAI MOTOR CO.

4. Loosen the bolts that attach the clutch cover to the flywheel in a star pattern.
5. Loosen the bolts in succession, one or two turns at a time, to avoid bending the cover flange.

CAUTION: DO NOT clean the clutch disc or release bearing with cleaning solvent.

INSPECTION

CLUTCH COVER ASSEMBLY

1. Check the diaphragm spring end for wear and uneven height.

Replace if wear is evident or height difference exceeds the limit.

Limit: 0.3 mm (0.012 in.)

2. Check the pressure plate surface for wear, cracks and color change.

3. Check the rivets for looseness and replace the clutch cover assembly if necessary.

CLUTCH DISC

1. Check the clutch facing for loose rivets, uneven contact, deterioration due to seizure, adhesion of oil, or grease, and replace the clutch disc if defective.
2. Measure the rivet sink and replace the clutch disc if it is out of specification

Limit: 1 .1 mm (0.044 in.)

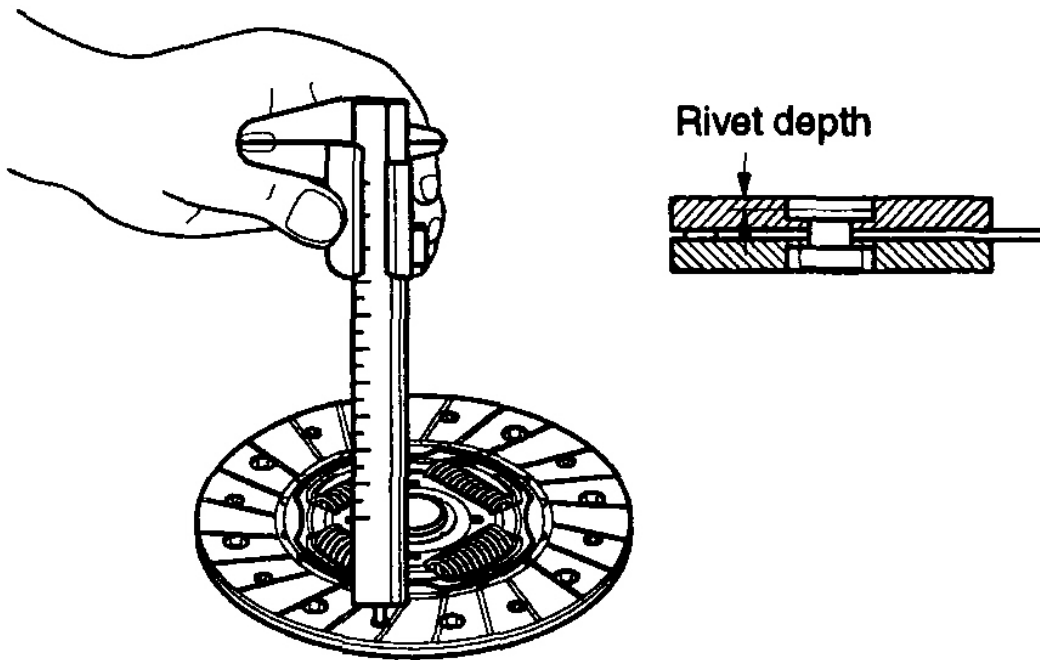

G03849634

Fig. 7: Measuring Rivet Sink & Replace Clutch Disc
 Courtesy of HYUNDAI MOTOR CO.

3. Check for torsion spring play and damage and if defective, replace the clutch disc.
4. Clean the splines on the input shaft and install the clutch disc.

If the disc does not slide smoothly or if play is excessive, replace the clutch disc and/or the input shaft.

CLUTCH RELEASE BEARING

CAUTION: The release bearing is packed with grease. Do not use cleaning solvent or

oil.

1. Check the bearing for seizure, damage or abnormal noise. Also check the diaphragm spring contacting points for wear.
2. Replace the bearing if the release fork contacting points are worn abnormally.

CLUTCH RELEASE FORK

If there is abnormal wear at the point of contact with the bearing, replace the release fork assembly.

INSTALLATION

1. Apply multipurpose grease to the release bearing contact surfaces and the release cylinder contact surface of the clutch release fork assembly.

CAUTION: When installing the clutch, apply grease to each part, but be careful not to apply excessive grease. It can cause clutch slippage and judder.

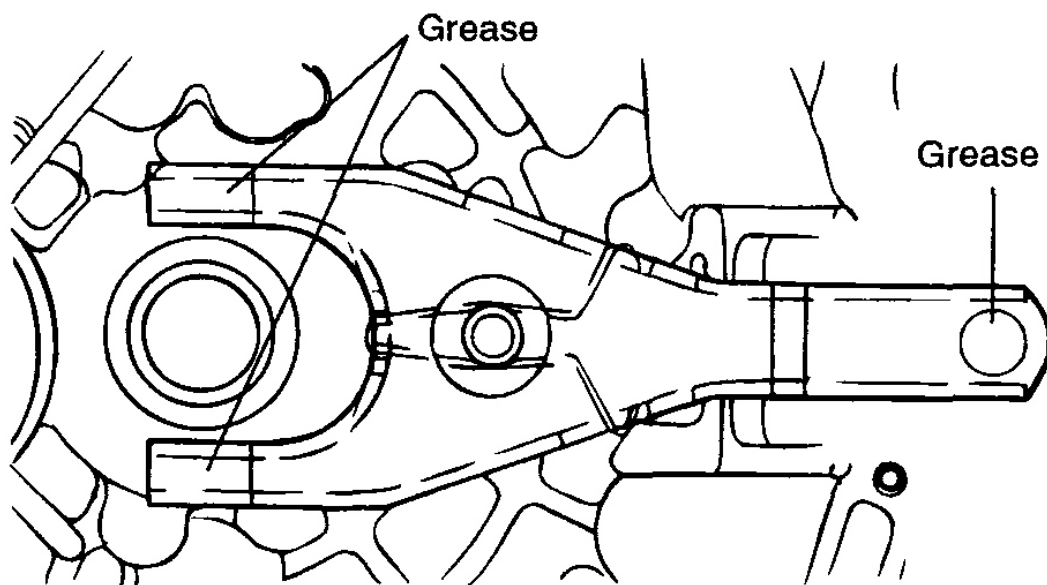

G03849635

Fig. 8: Applying Multipurpose Grease To Specified Area
Courtesy of HYUNDAI MOTOR CO.

2. Apply multipurpose grease into the groove of the release bearing.

Grease: CASMOLY L9508

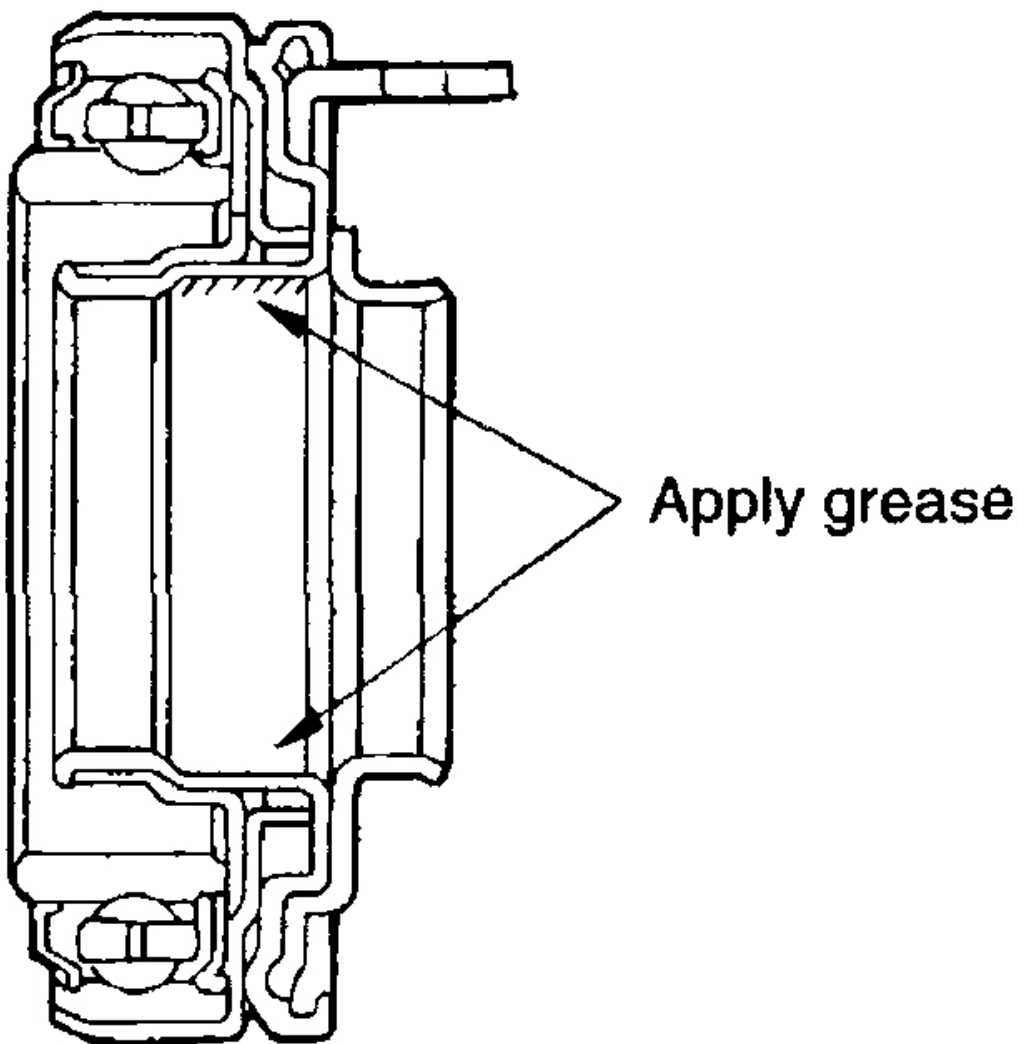

G03849636

Fig. 9: Applying Multipurpose Grease Into Groove
Courtesy of HYUNDAI MOTOR CO.

3. Apply multipurpose grease to the clutch release lever fulcrum contact surface of the clutch release fork assembly.

Grease: CASMOLY L9508

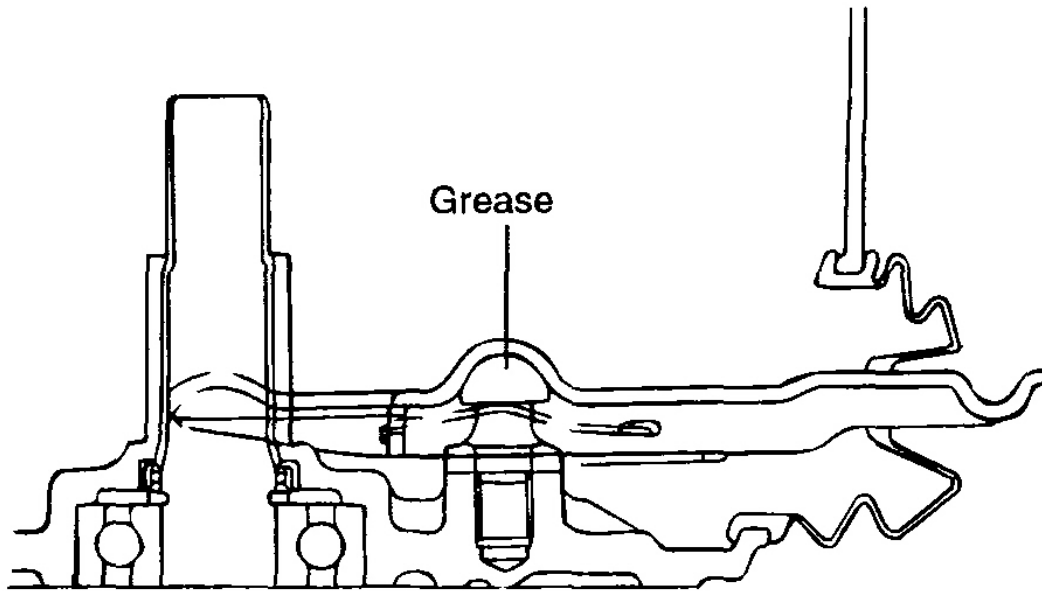

G03849637

Fig. 10: Applying Multipurpose Grease To Clutch
 Courtesy of HYUNDAI MOTOR CO.

4. Clean the surfaces of the flywheel and pressure plate thoroughly with fine sandpaper or crocus cloth, and make certain that all oil or grease has been removed.
5. Apply a small amount of multipurpose grease to the clutch disc splines and input shaft splines.

Grease: CASMOLY L9508

CAUTION: Do not apply more grease than necessary. Too much grease could cause clutch slip or judder.

6. Using the special tool (09411-25000), install the clutch disc to the flywheel. When installing the clutch disc, be sure that the surface having the manufactures stamp is towards the pressure plate side.
7. Install the clutch cover assembly onto the flywheel and install the six (6) bolts through the clutch cover into the flywheel.
8. Tighten the bolts by one or two turns at a time, in succession, to avoid bending the cover flange.

If a special tool is not available, tighten the bolt temporarily and then torque to specification in diagonal torquing sequence indicated below.

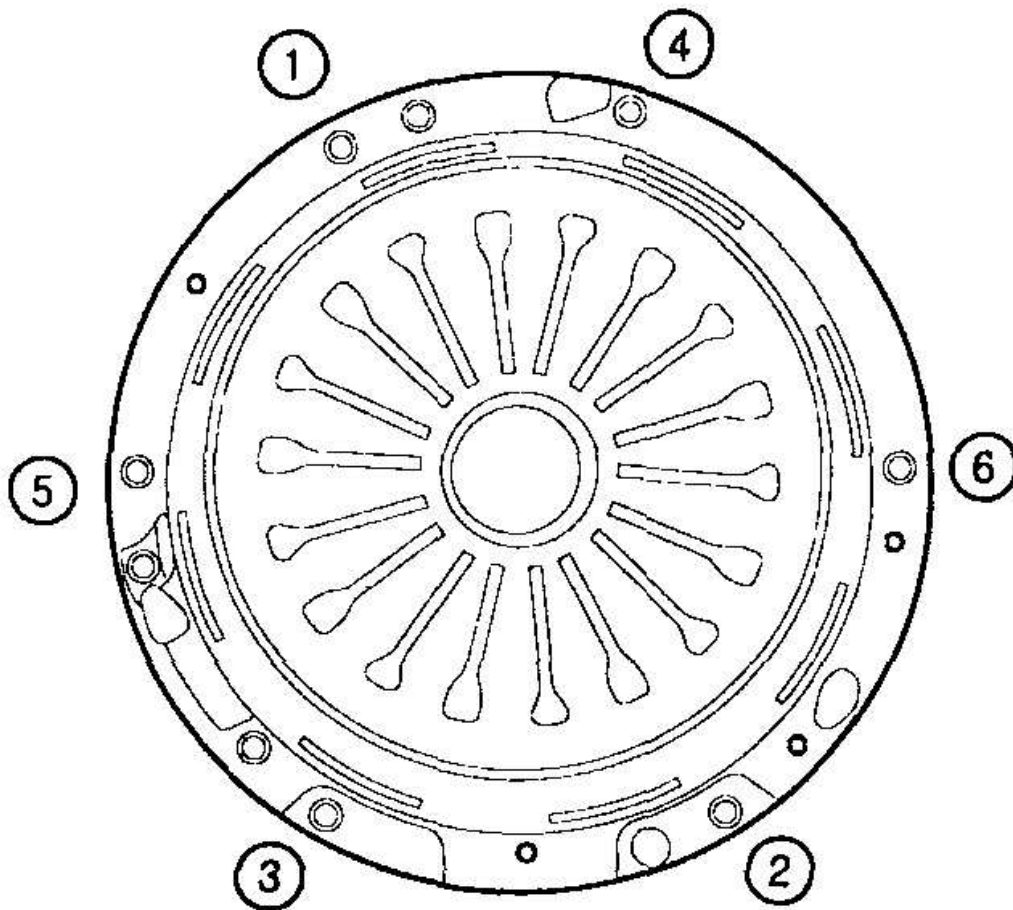

G03849638

Fig. 11: Tightening Bolts Sequence
Courtesy of HYUNDAI MOTOR CO.

TIGHTENING TORQUE

Single mass flywheel:

15~22 N.m (150~220 kgf.cm, 11~16 lbf.ft)

Dual mass flywheel:

20~27 N.m (200~270 kgf.cm, 14~19 lbf.ft)

2006 Hyundai Tiburon GT

2006 TRANSMISSION Clutch System - Tiburon

9. Remove the special tool.
10. Install the transaxle