

## REAR DOOR LATCH

### Removal

#### All Vehicles

1. Remove the rear door interior trim panel. For additional information, refer to **INTERIOR TRIM AND ORNAMENTATION**.
2. Remove the access hole watershield.
3. Reconnect the window regulator and window switch electrical connectors and position the front door window to access the glass clamp bolt.

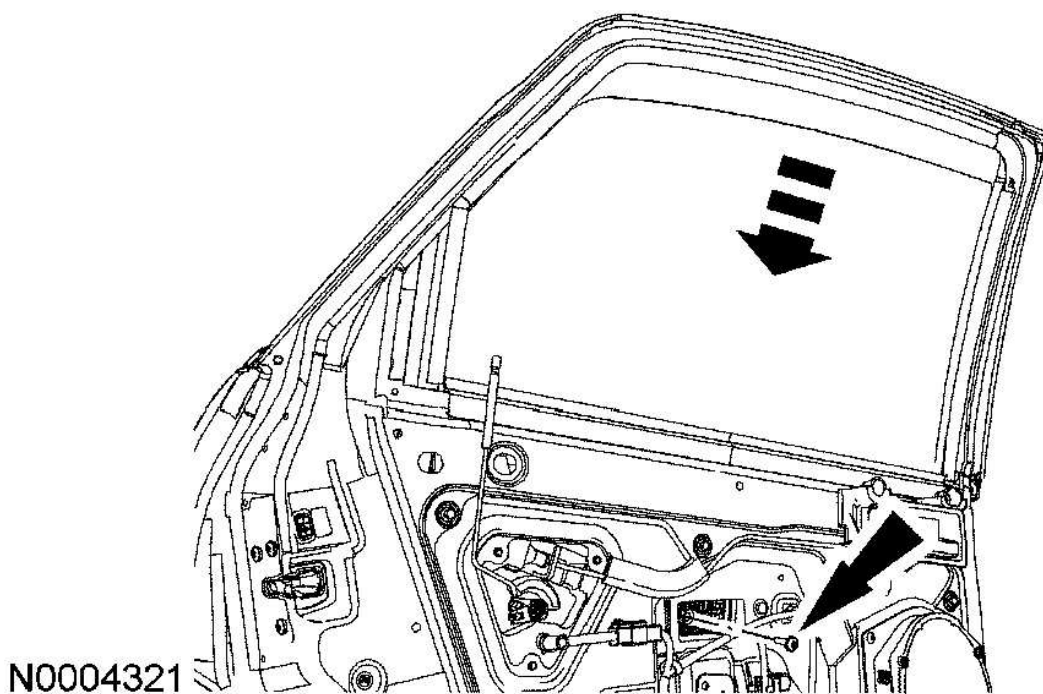

**Fig. 48: Removing Front Door Window To Access Glass Clamp Bolt**  
Courtesy of FORD MOTOR CO.

4. Disconnect the window regulator and window switch electrical connectors
5. Loosen the window glass clamp bolt.
6. Tape the window in the full up position, then lower the window regulator downward until it reaches the stops at the bottom of the regulator track.
7. Remove the interior door handle bolt.
8. Disconnect the rear door latch assembly electrical connector.

## 2005 Ford Five Hundred SE

2005 ACCESSORIES AND BODY, CAB Handles, Locks, Latches and Entry Systems - Freestyle, Five Hundred, Montego

9. Rotate the push button rod downward and remove it from the rear door latch assembly.
10. Remove the 3 rear door latch assembly-to-rear door module bolts.

**NOTE:** Make sure that the interior door handle does not get scratched when it is passed through the rear door module.

11. Remove the 8 bolts and position the rear door module aside.

### Five Hundred and Montego Vehicles

12. Remove the tape and lower the window glass.
13. Remove the scrivet.

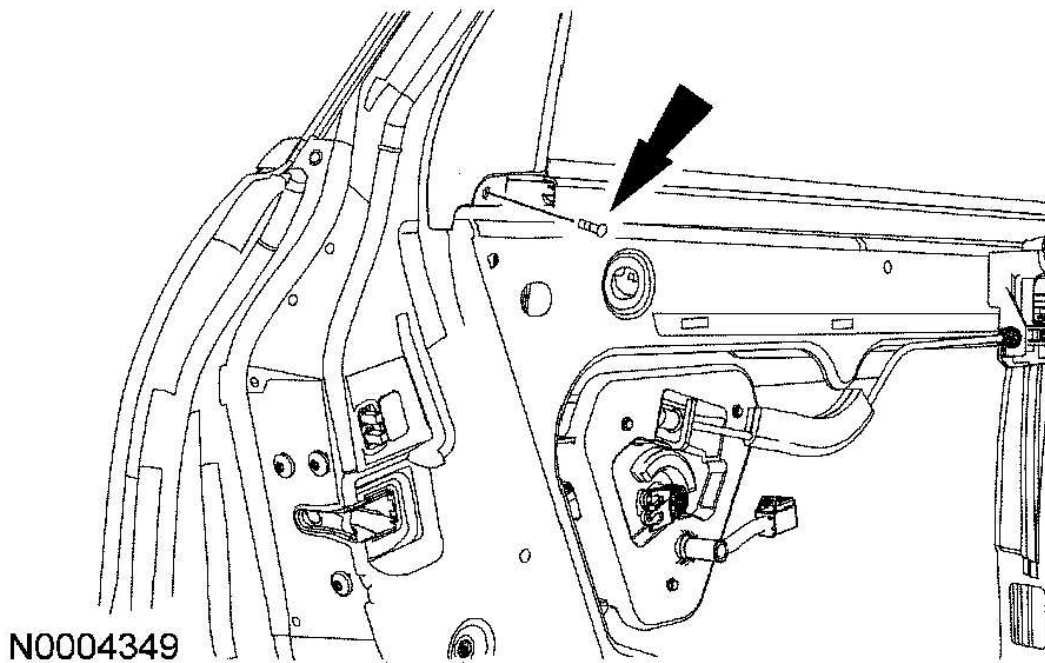
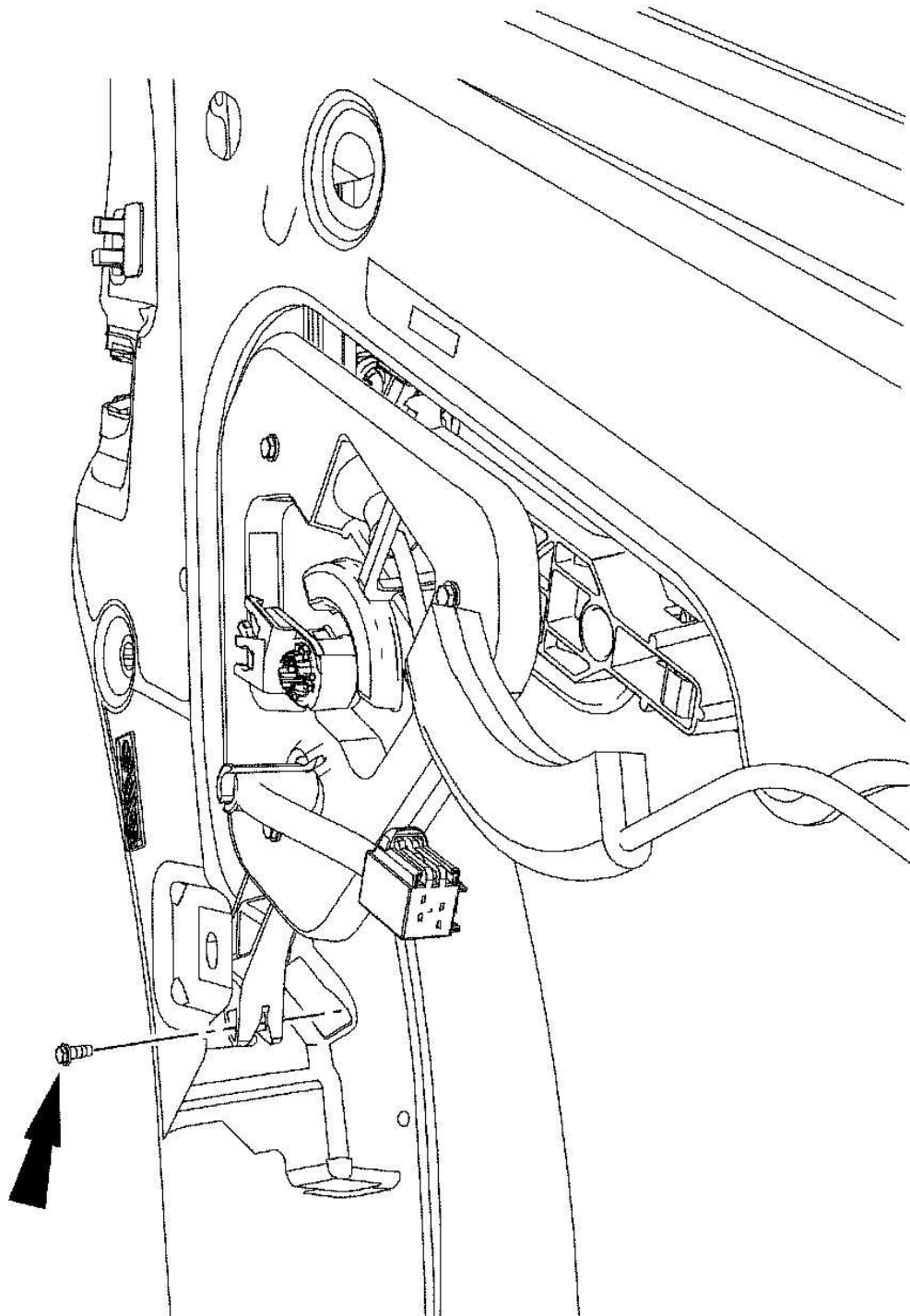

**Fig. 49: Removing Scrivet**  
Courtesy of FORD MOTOR CO.

14. Remove the rear door glass run top bolt.

**2005 Ford Five Hundred SE**

2005 ACCESSORIES AND BODY, CAB Handles, Locks, Latches and Entry Systems - Freestyle, Five Hundred, Montego



N0004516

**Fig. 50: Removing Rear Door Glass Run Top Bolt**

**Courtesy of FORD MOTOR CO.**

15. Remove the rear door glass run seal.
16. Carefully position the glass aside, then remove the rear door glass top run.

**All Vehicles**

17. Disconnect the exterior door handle actuating rod from the rear door latch.
18. Remove the 3 rear door latch bolts.
19. Remove the rear door latch assembly.
20. Remove the remote cable cover from the latch.
21. Disconnect the interior door handle actuating cable from the rear door latch.
22. Remove the rear door latch from the bracket.

**Installation**

**All Vehicles**

1. Install the rear door latch on the bracket.
2. Connect the interior door handle actuating cable to the rear door latch.
3. Install the remote cable cover on the latch.
4. Position the rear door latch assembly.
5. Install the 3 rear door latch bolts.
  - Tighten to 12 Nm (9 lb-ft).

**CAUTION: The exterior door handle and the door latch must be installed and tightened to specification before connecting the exterior door handle actuating rod with the yellow clip.**

**CAUTION: The exterior door handle actuating rod must be hanging freely then clipped into the door latch. Loading the exterior door handle actuating rod up or down when connecting may result in a misadjustment of the latch causing the latch not to operate correctly.**

6. Connect the exterior door handle actuating rod to the rear door latch and close the yellow clip.

**Five Hundred and Montego Vehicles**

7. Install the rear door glass top run and carefully position the glass.
8. Install the rear door glass run seal.
9. Install the rear door glass run top bolt.

**2005 Ford Five Hundred SE**

2005 ACCESSORIES AND BODY, CAB Handles, Locks, Latches and Entry Systems - Freestyle, Five Hundred, Montego

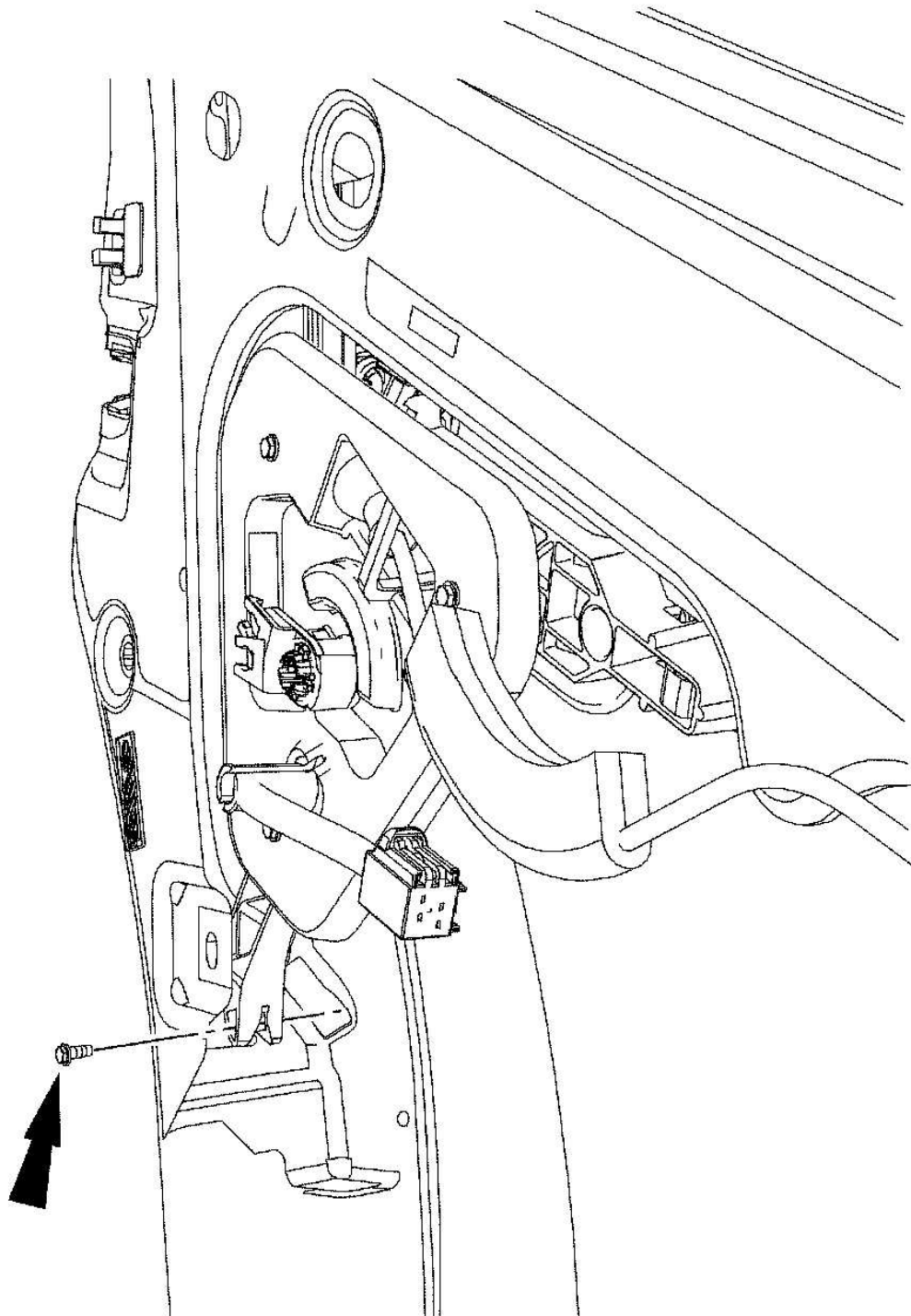

N0004516

**Fig. 51: Installing Rear Door Glass Run Top Bolt**

Courtesy of FORD MOTOR CO.

10. Install the scrivet.

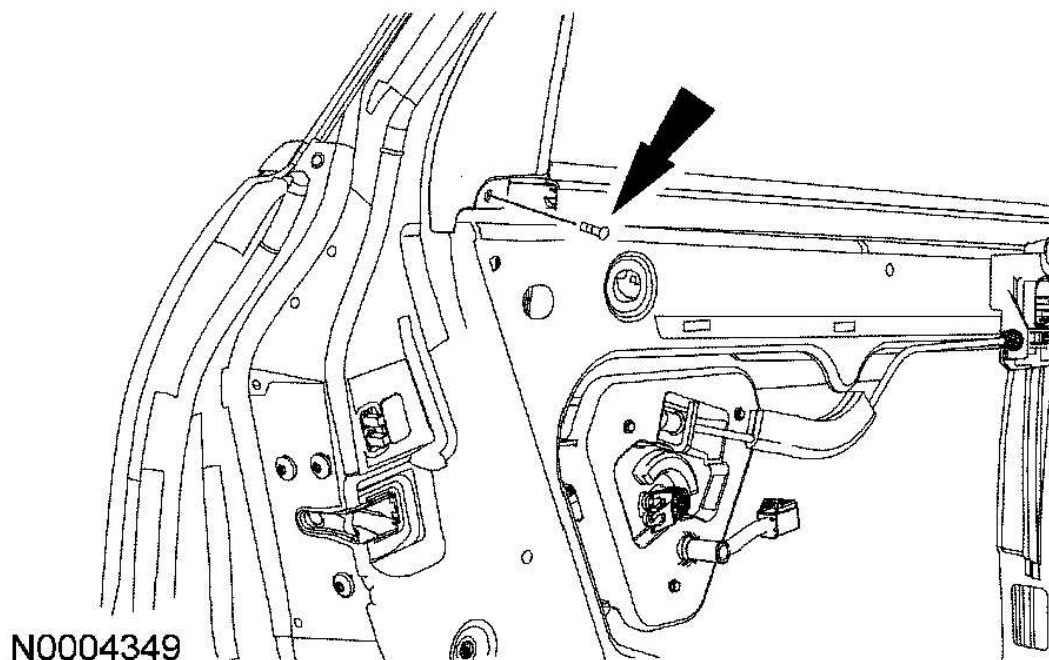

**Fig. 52: Installing Scrivet**  
Courtesy of FORD MOTOR CO.

11. Raise the window glass and tape it in the full up position.

**All Vehicles**

**NOTE:** Make sure that the interior door handle does not get scratched when it is passed through the rear door module.

12. Position the rear door module and install the 8 bolts.
  - Tighten to 8 Nm (71 lb-in).
13. Install the 3 rear door latch assembly-to-rear door module bolts.
  - Tighten to 12 Nm (9 lb-ft).
14. Install push button rod on the rear door latch assembly.
15. Connect the rear door latch assembly electrical connector.
16. Position the interior door handle and loosely install the bolt.

17. Untape the window glass, then lower the window glass.
18. Tighten the window glass clamp bolt.
  - Position the window in the window clamp.
  - Shift the door window glass fully forward.
  - Tighten the window glass bolt to 8 Nm (71 lb-in).
19. Install the access hole watershield.
20. Install the rear door trim panel. For additional information, refer to **INTERIOR TRIM AND ORNAMENTATION**.
21. Center the inside door handle alignment pins to the rear door trim panel and tighten the interior door handle bolt.
  - Tighten to 7 Nm (62 lb-in).

## EXTERIOR REAR DOOR HANDLE

### Removal

1. Remove the rear door latch. For additional information, refer to **REAR DOOR LATCH**.

**CAUTION: Hold the bezel cap when removing the bolt or damage to the door may occur.**

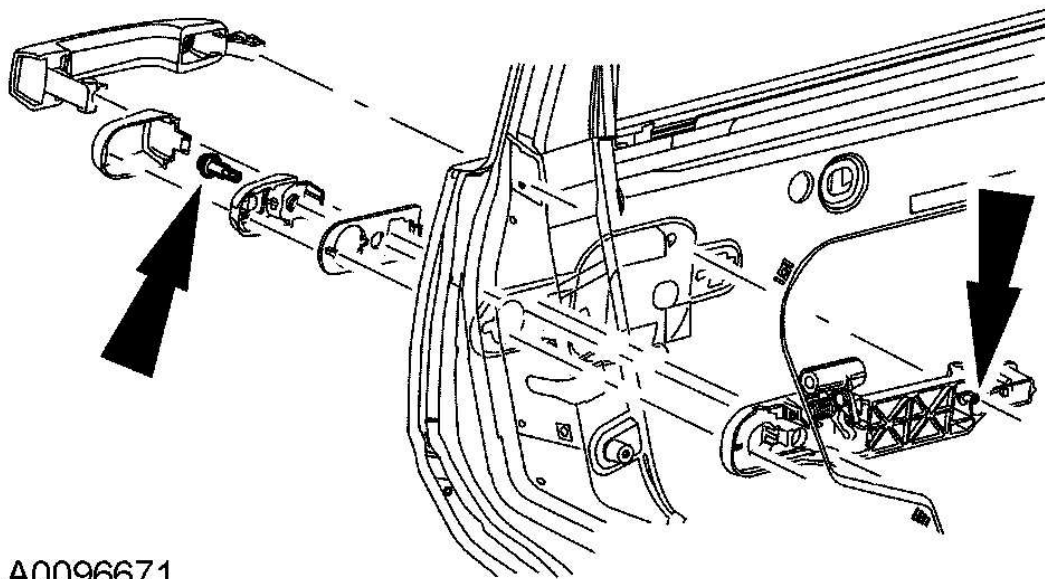
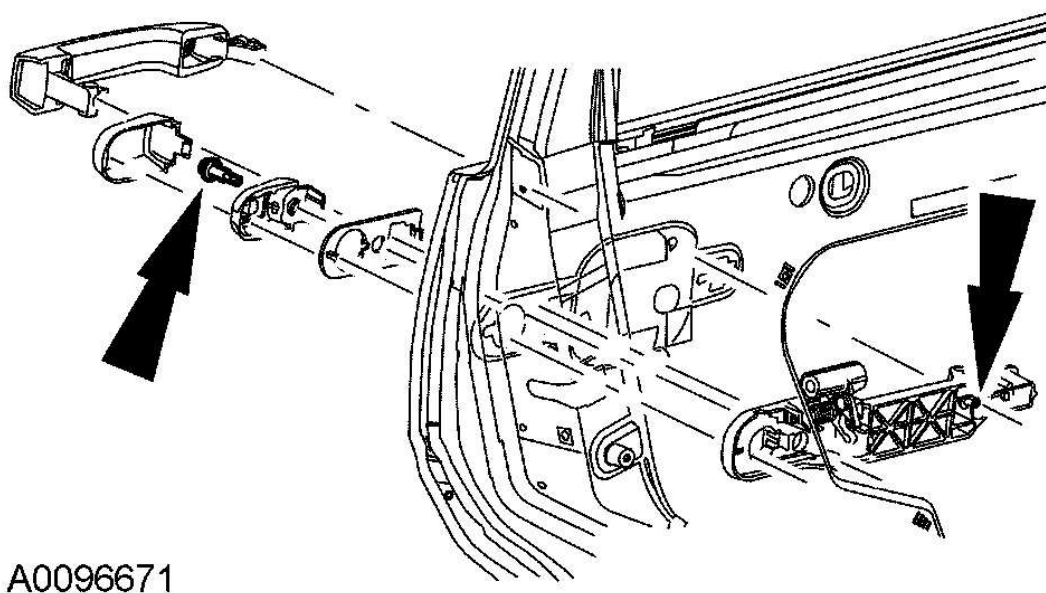

**Fig. 53: Removing Bezel Cap Bolt**  
Courtesy of FORD MOTOR CO.

2. Using a T-5 torx socket installed on the bolt tip, loosen the bezel cap bolt until the bezel cap can be removed.
3. Shift the exterior door handle rearward and remove the exterior door handle.
4. Remove the exterior door handle gasket.
5. Loosen the exterior door handle reinforcement bolt.
6. Remove the exterior door handle reinforcement from inside the door.
7. Release the bezel cap from the bezel and remove the bezel cap bolt.

**Installation**

1. Install the exterior door handle reinforcement on inside the door.
2. Tighten the exterior door handle reinforcement bolt.
  - Tighten to 7 Nm (62 lb-in).



**Fig. 54: Installing Exterior Door Handle Reinforcement Bolt**  
Courtesy of FORD MOTOR CO.

3. Install the exterior door handle gasket.
4. Install the exterior door handle.
5. Install the bezel and the bezel cap bolt.
  - Tighten to 12 Nm (9 lb-ft).
6. Position the exterior door handle forward.
7. Snap the bezel cap on to the bezel.

**2005 Ford Five Hundred SE**

2005 ACCESSORIES AND BODY, CAB Handles, Locks, Latches and Entry Systems - Freestyle, Five Hundred, Montego

8. Install the rear door latch. For additional information, refer to [REAR DOOR LATCH](#)