

STARTER

Removal & Installation (With 4-Speed Automatic 01M Transaxle & 5-Speed Manual 02J Transaxle)

1. Disconnect negative battery cable. Remove battery, and battery carrier. See **Fig. 2**.
2. Disconnect all wiring from starter solenoid. Remove starter cable from retainer. Remove starter wiring from guides. Remove guides.
3. Raise and support vehicle. Remove noise insulation panel. See **Fig. 3**. Remove left-side insulation panel. See **Fig. 4**. Remove brackets/retainers securing power steering pressure line. Place power steering pressure line aside.
4. Remove bolts securing starter. See **Fig. 5**. Remove starter. To install, reverse removal procedure. Tighten starter mounting bolt/nuts to specification. See **TORQUE SPECIFICATIONS**.

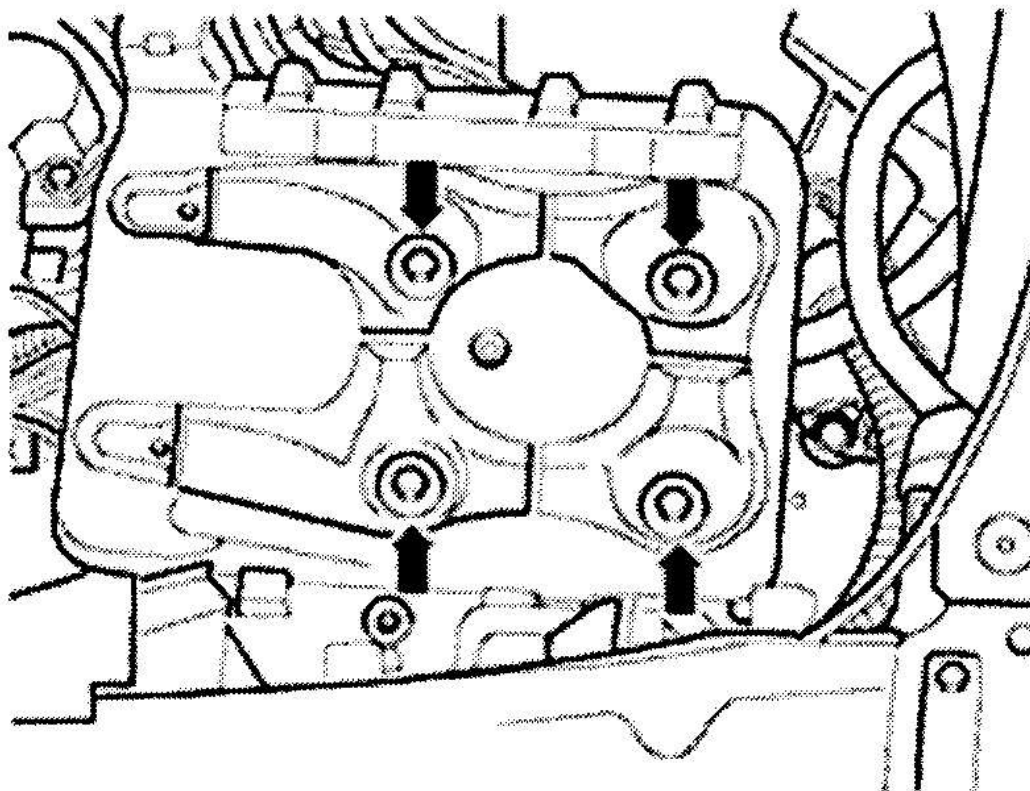

G00317182

Fig. 2: Identifying Battery Carrier Mounting Points

Courtesy of VOLKSWAGEN UNITED STATES, INC.

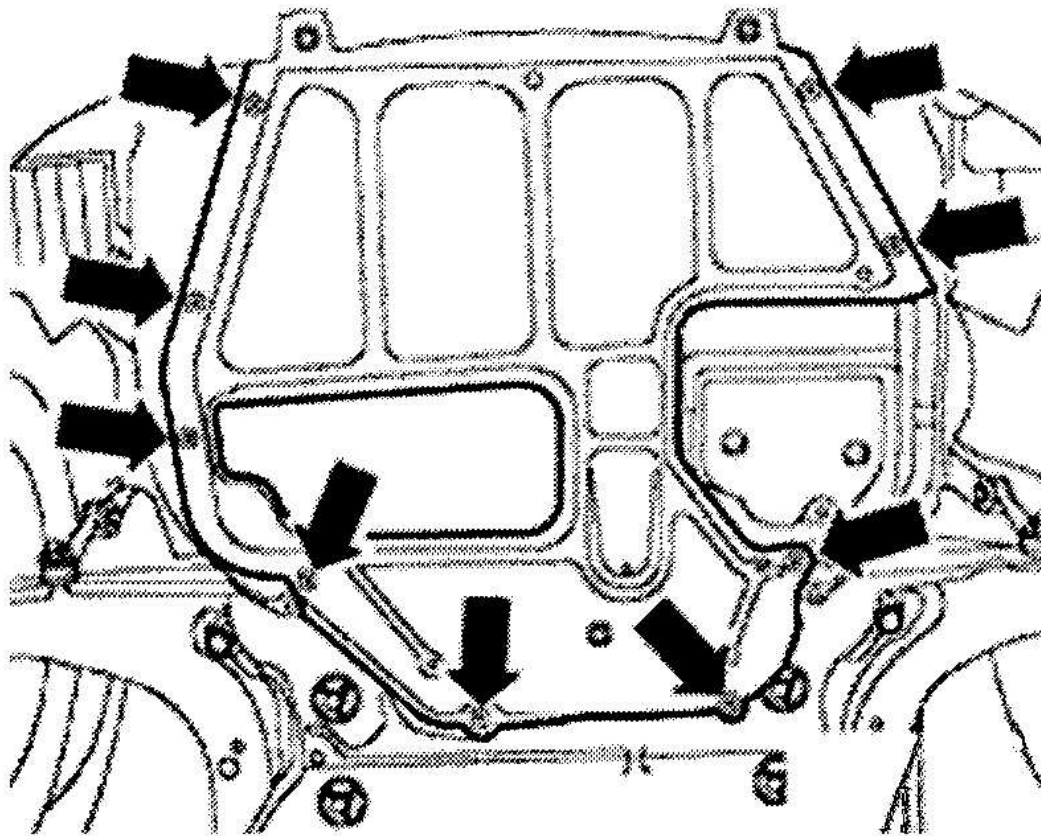

G00317180

[Fig. 3: Identifying Noise Insulation Panel Mounting Points](#)

Courtesy of VOLKSWAGEN UNITED STATES, INC.

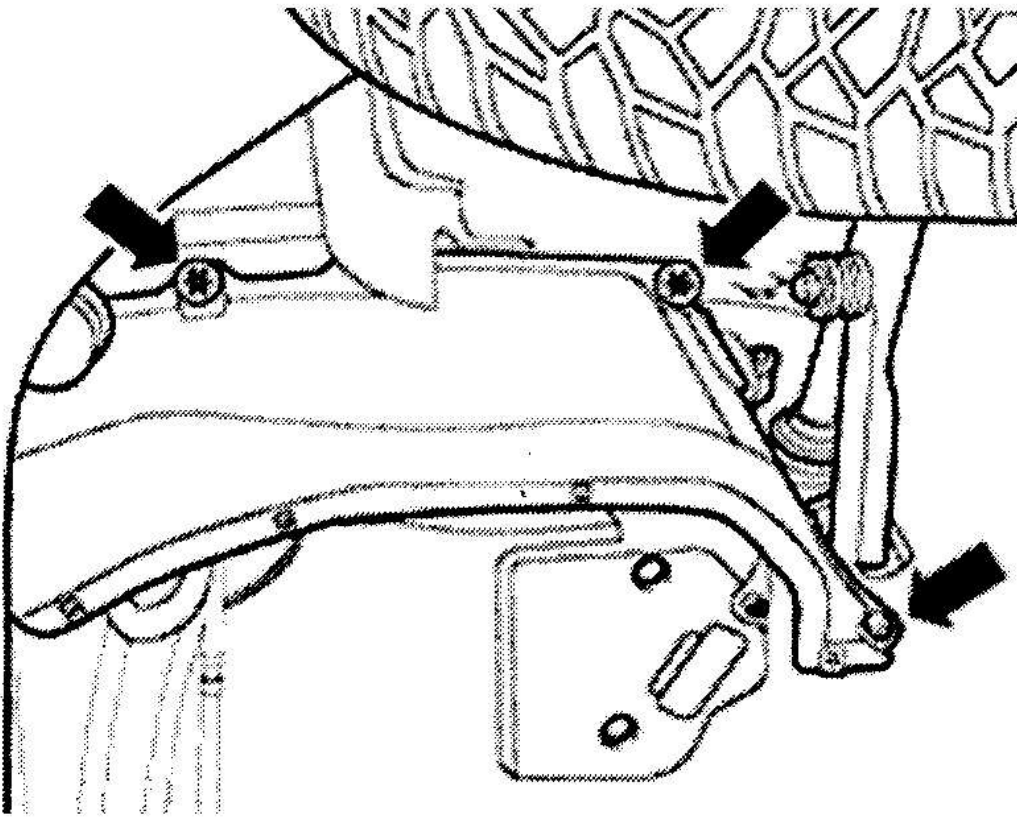

G00317183

Fig. 4: Identifying Left-Side Noise Insulation Panel Mounting Points
Courtesy of VOLKSWAGEN UNITED STATES, INC.

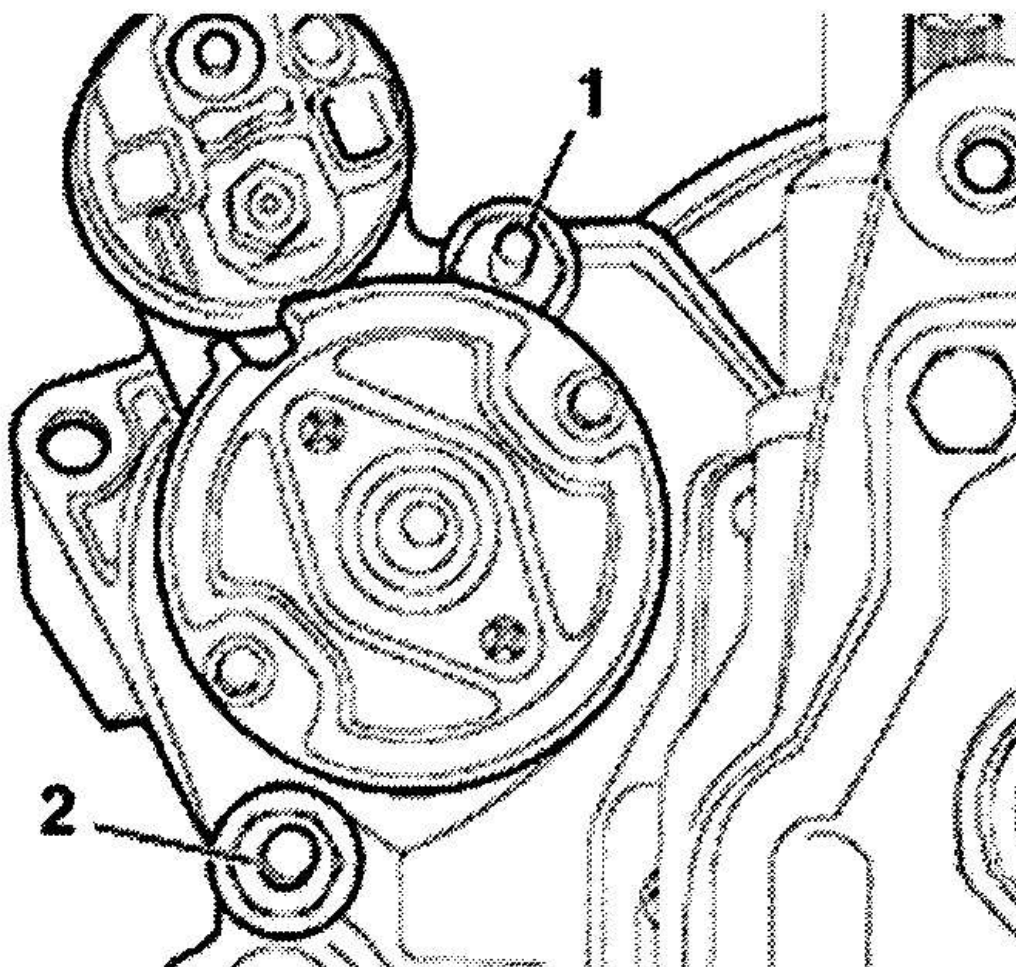

G00317184

Fig. 5: Removing Starter

Courtesy of VOLKSWAGEN UNITED STATES, INC.

Removal & Installation (With 5-Speed Automatic Transaxle, 09A)

1. Disconnect negative battery cable. Remove engine cover. Disconnect intake hose, wiring harness connector, and hose from Mass Air Flow (MAF) sensor. Remove screws securing air filter housing assembly. Remove air filter housing assembly.

**CAUTION: DO NOT remove screw (2) from shifter lever cable end. See Fig. 6 .
DO NOT kink shifter cable while removing.**

NOTE: Ensure transaxle gearshift lever is in "Park".

2. Remove bracket (arrow) from transaxle. See **Fig. 6** . Using a flat-bladed screwdriver, unclip shifter cable from holder, and set aside.
3. Remove starter solenoid plastic protective cover. See **Fig. 7** . Remove starter solenoid nut, and cable from starter solenoid. Disconnect starter solenoid wiring harness connector.
4. Remove 2 bolts securing starter to transaxle. See **Fig. 8** . Lift starter up and out from transaxle. To install, reverse removal procedure. Tighten starter mounting bolt/nuts to specification. See **TORQUE SPECIFICATIONS** .

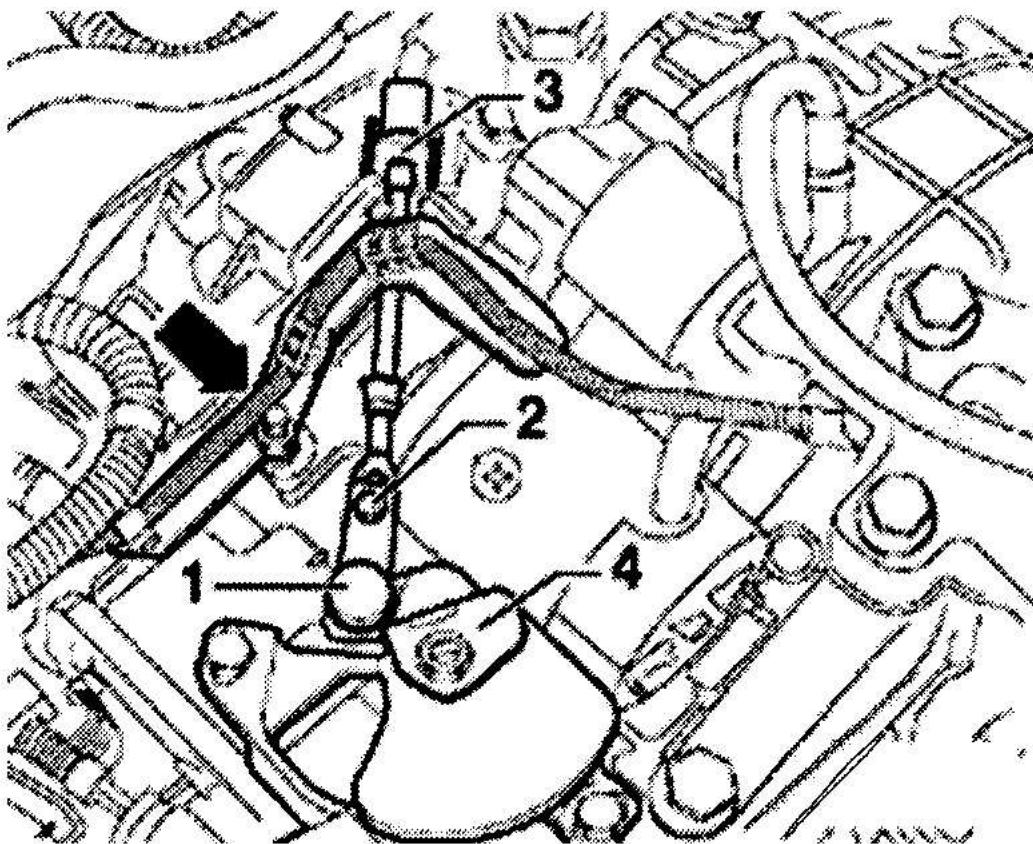

G00317185

Fig. 6: Detaching Shifter Lever Cable

Courtesy of VOLKSWAGEN UNITED STATES, INC.

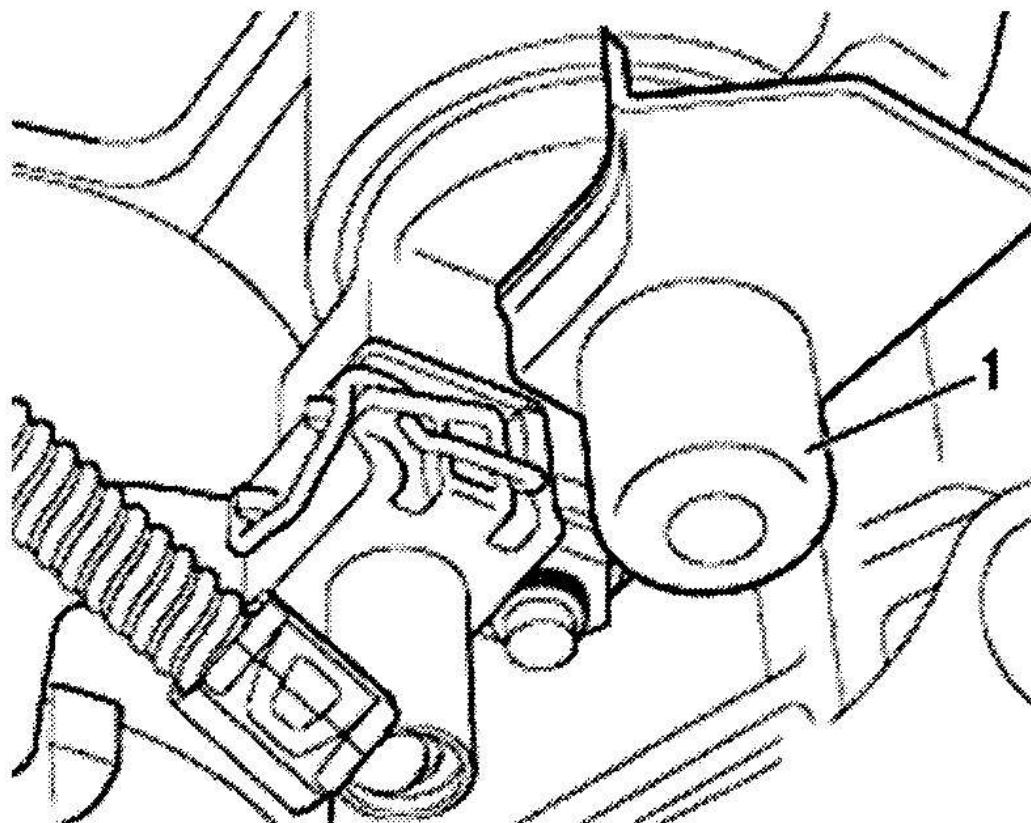

G00317186

Fig. 7: Identifying Starter Solenoid Plastic Protective Cover
Courtesy of VOLKSWAGEN UNITED STATES, INC.

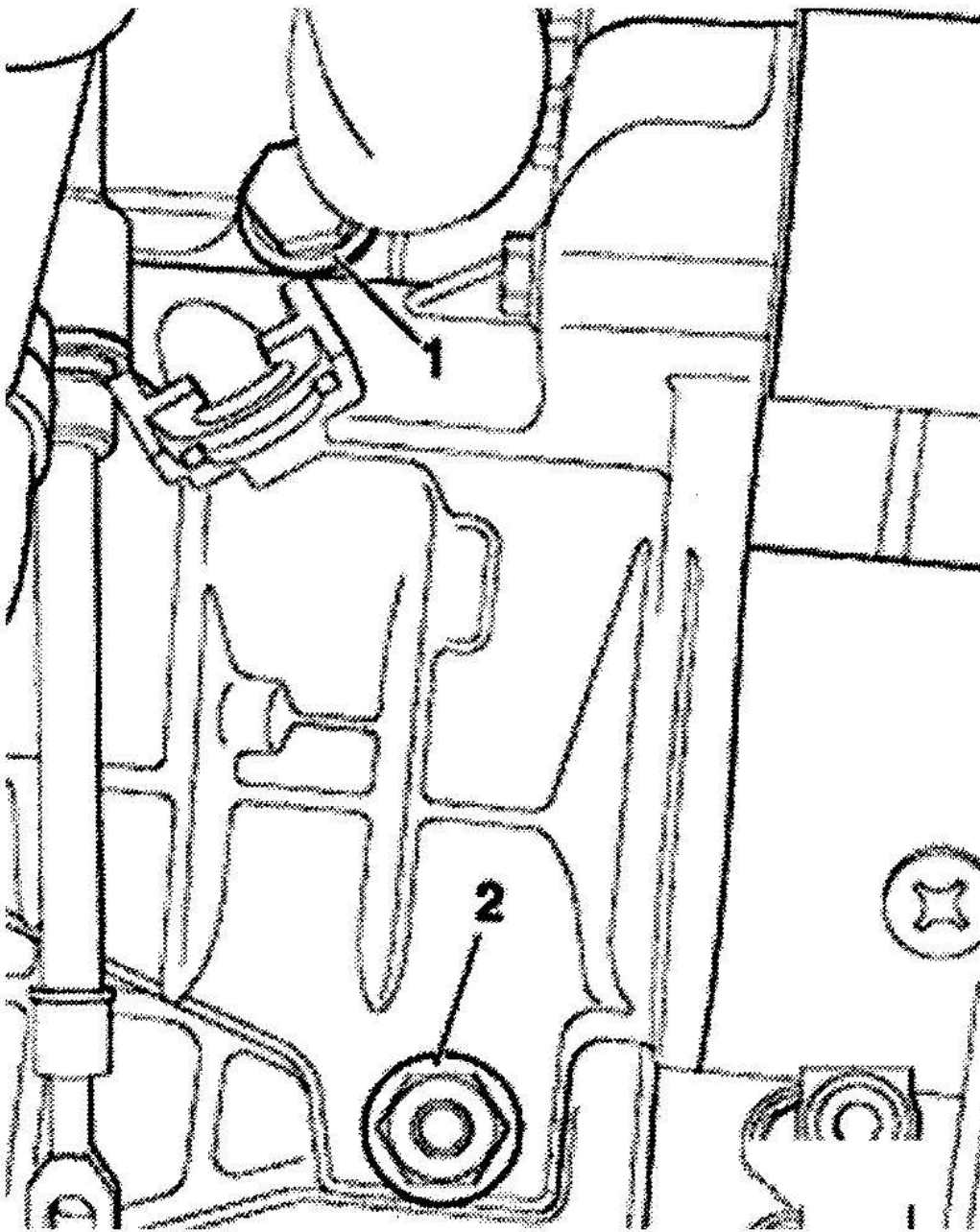

G00283878

Fig. 8: Removing Starter Mounting Bolts (With 5-Speed Automatic Transaxle, 09A)

Courtesy of VOLKSWAGEN UNITED STATES, INC.

OVERHAUL

2001 Volkswagen Jetta GL

2001-04 STARTING & CHARGING SYSTEMS Starters - Golf, GTI & Jetta

Manufacturer recommends replacing starter as an assembly. Exploded view and overhaul procedures are not available from manufacturer.

TORQUE SPECIFICATIONS

TORQUE SPECIFICATIONS

Application	Ft. Lbs. (N.m)
Starter Mounting Bolt	48 (65)
	INCH Lbs. (N.m)
Battery Carrier Bolt	53 (6)
Starter Solenoid Terminal Nut	115 (13)