

Air-Conditioning,

from September 1997

- 1,8L- Engine - Motronic Multiport Fuel Injection (MFI)/110 kW, code AEB,
- 2,8l - Motronic Multiport Fuel Injection (MFI) / 142kW, code AHA,

Deviate relay location and fuseplacements as well as the locations of multiple connectors see section "component locations".

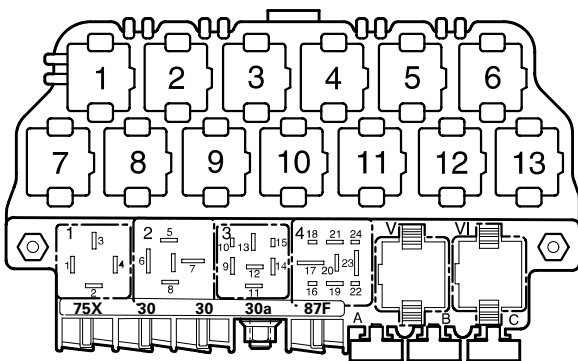

97-20676

Relay location on the thirteenfold auxiliary relay panel, above relay panel:

- 4** A/C Cut-Off Control Module (384)

Relay panel:

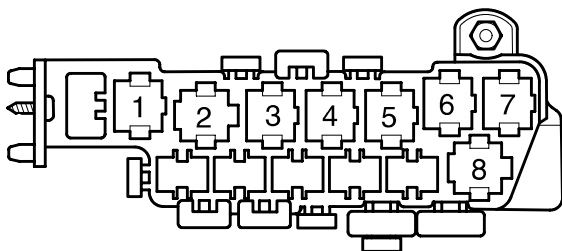

97-20515

Relay location on the eightfold auxiliary relay panel, behind relay panel:

- 5** First Speed Coolant Fan Control (FC) Relay (214)
- 8** Second Speed Coolant Fan Control (FC) Relay (213)

Note: Number in parentheses indicates production control number stamped on relay housing.

Fuse colors

30 A - green
 25 A - white
 20 A - yellow
 15 A - blue
 10 A - red
 7,5 A - brown
 5 A - beige

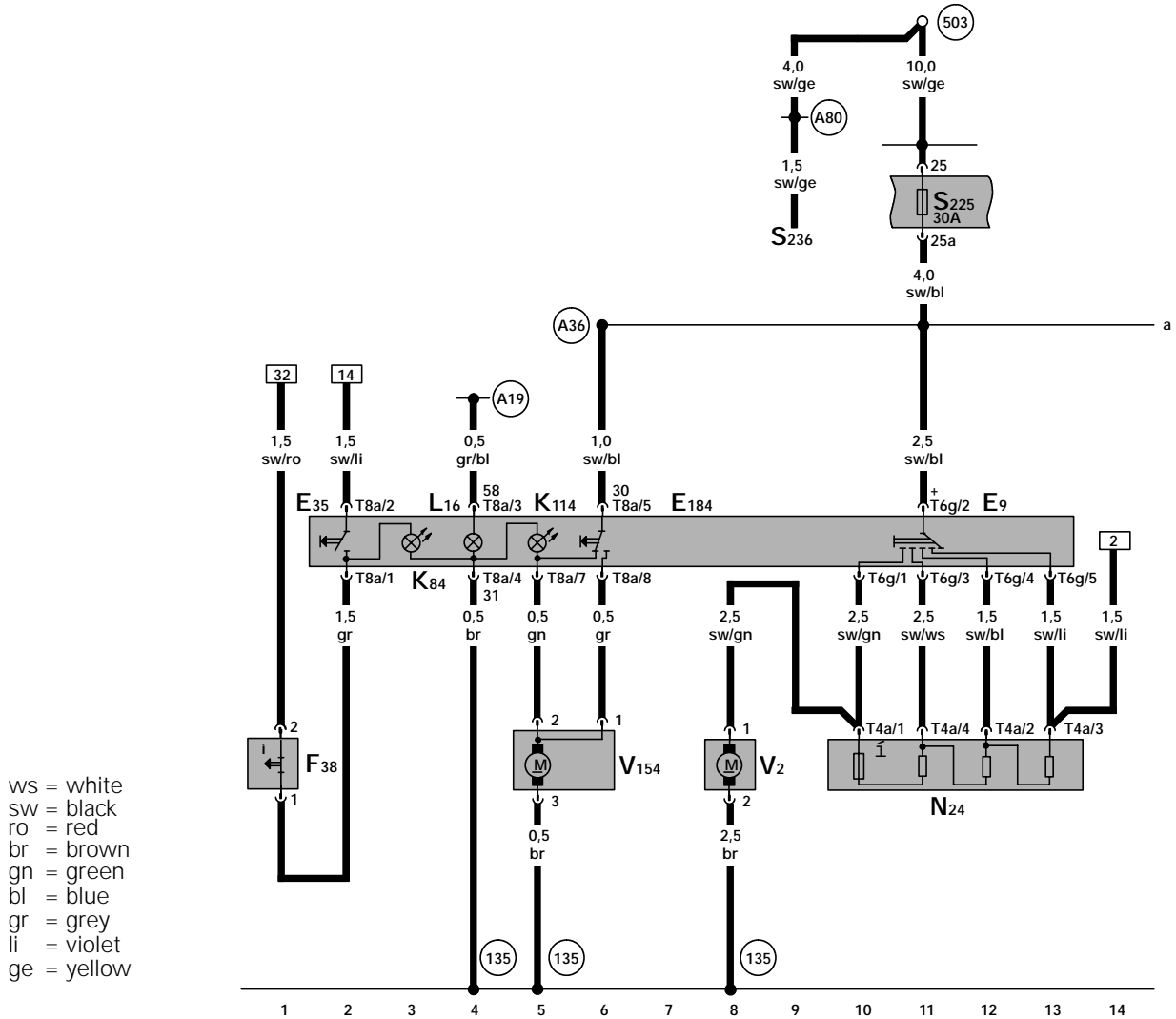

ws = white
 sw = black
 ro = red
 br = brown
 gn = green
 bl = blue
 gr = grey
 li = violet
 ge = yellow

97-21081

- E9 - Fresh Air Blower Switch
- E35 - A/C Switch
- E184 - Switch for fresh air blower and recirculated air
- F38 - Ambient Temperature Switch
- K84 - A/C Indicator Light
- K114 - Fresh Air and Recirculating Air Mode Indicator Light
- L16 - Fresh Air Control Lever Light
- N24 - Fresh Air Blower Series Resistance With Fuse
- S225 - Fuse 25 in fuse holder
- S236 - Fuse 36 in fuse holder
- T4a - 4-Pin Connector
- T6g - 6-Pin Connector
- T8a - 8-Pin Connector
- V2 - Fresh Air Blower
- V154 - Servo motor for fresh-/recirculating air door

- (135) - Ground connection -2-, in instrument panel wiring harness
- (503) - Screw Connection (75x), on relay panel
- (A19) - wire connection (58d), in instrument panel wiring harness
- (A36) - wire connection (75a), in instrument panel wiring harness
- (A80) - Connector -1- (X), in instrument panel wiring harness

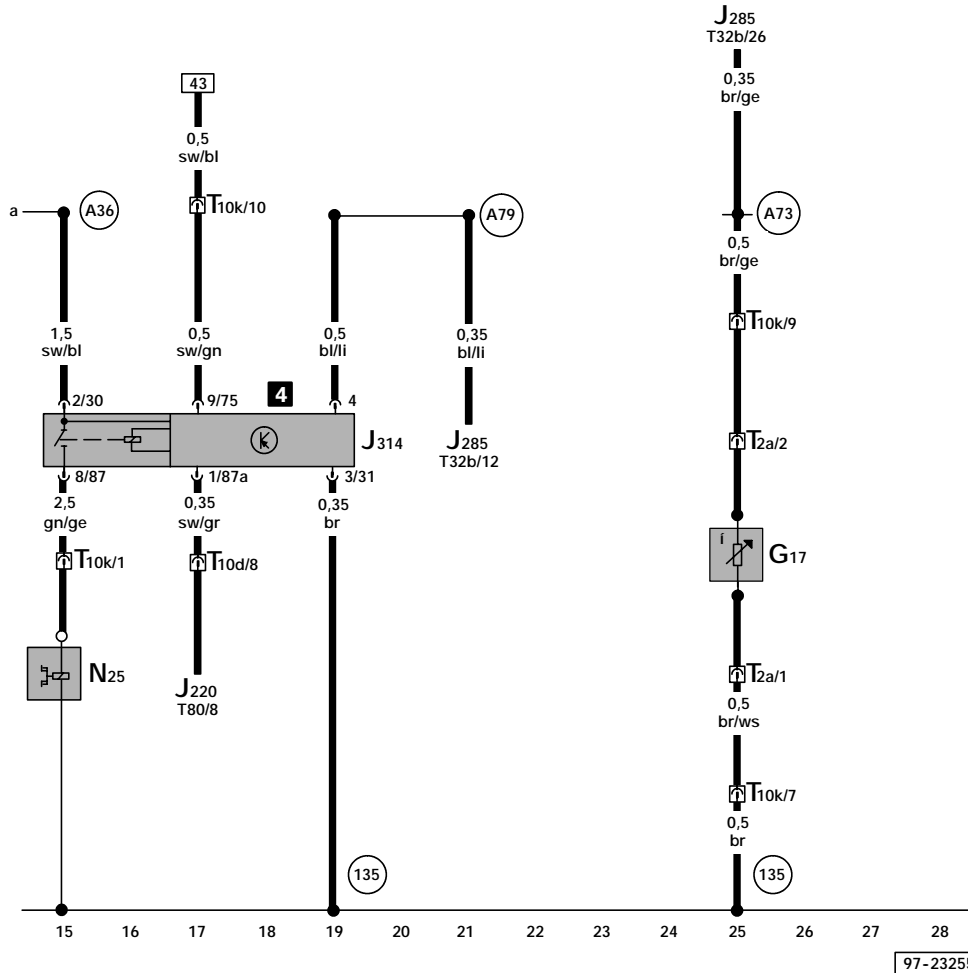

ws = white
 sw = black
 ro = red
 br = brown
 gn = green
 bl = blue
 gr = grey
 li = violet
 ge = yellow

- G17 - Outside Air Temperature Sensor
- J220 - Motronic Engine Control Module (ECM)
- J285 - Control module with indicator unit in instrument panel insert
- J314 - A/C Cut-Off Control Module, on thirteenfold auxiliary relay panel, above relay panel, production control number (384)
- N25 - A/C Clutch
- T2a - Double Connector
- T10d - 10-Pin Connector, brown, on protective housing for control module, in engine compartment, left
- T10k - 10-Pin Connector, grey, connector station A-pillar, left
- T32b - 32-Pin Connector, green, on instrument cluster
- T80 - Connector, 80 point, on Engine Control Module (ECM)

- (135) - Ground connection -2-, in instrument panel wiring harness
- (A36) - wire connection (75a), in instrument panel wiring harness
- (A73) - Connector (outside temperature indicator), in instrument panel wiring harness
- (A79) - Connector (engine overheat warning light), in instrument panel wiring harness

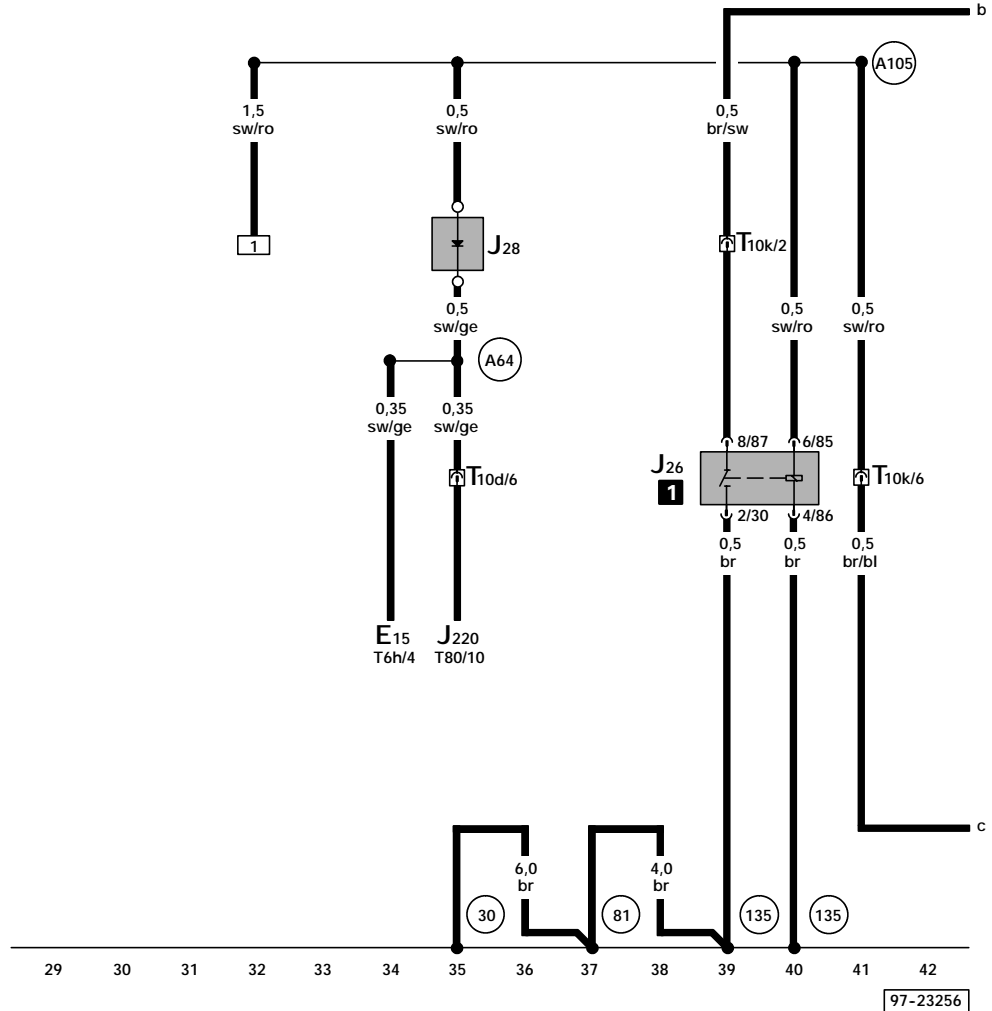

ws = white
 sw = black
 ro = red
 br = brown
 gn = green
 bl = blue
 gr = grey
 li = violet
 ge = yellow

- E15 - Rear window defogger switch
- J26 - Coolant Fan control (FC) Relay, on the thirteenfold auxiliary relay panel, above relay panel, production control number (214)
- J28 - A/C Diode
- J220 - Motronic Engine Control Module (ECM)
- T6h - 6-Pin Connector, black, on rear window defogger switch
- T10d - 10-Pin Connector, brown, on protective housing for control module, in engine compartment, left
- T10k - 10-Pin Connector, grey, connector station A-pillar, left
- T80 - Connector, 80 point, on Motronic Engine Control Module (ECM)

- (30) - Ground connection -1-, beside fuse/relay panel
- (81) - Ground connection -1-, in instrument panel wiring harness
- (135) - Ground connection -2-, in instrument panel wiring harness
- (A64) - Connector (30, idle boost), in instrument panel wiring harness
- (A105) - Connector -2- (rpm increase), in instrument panel wiring harness

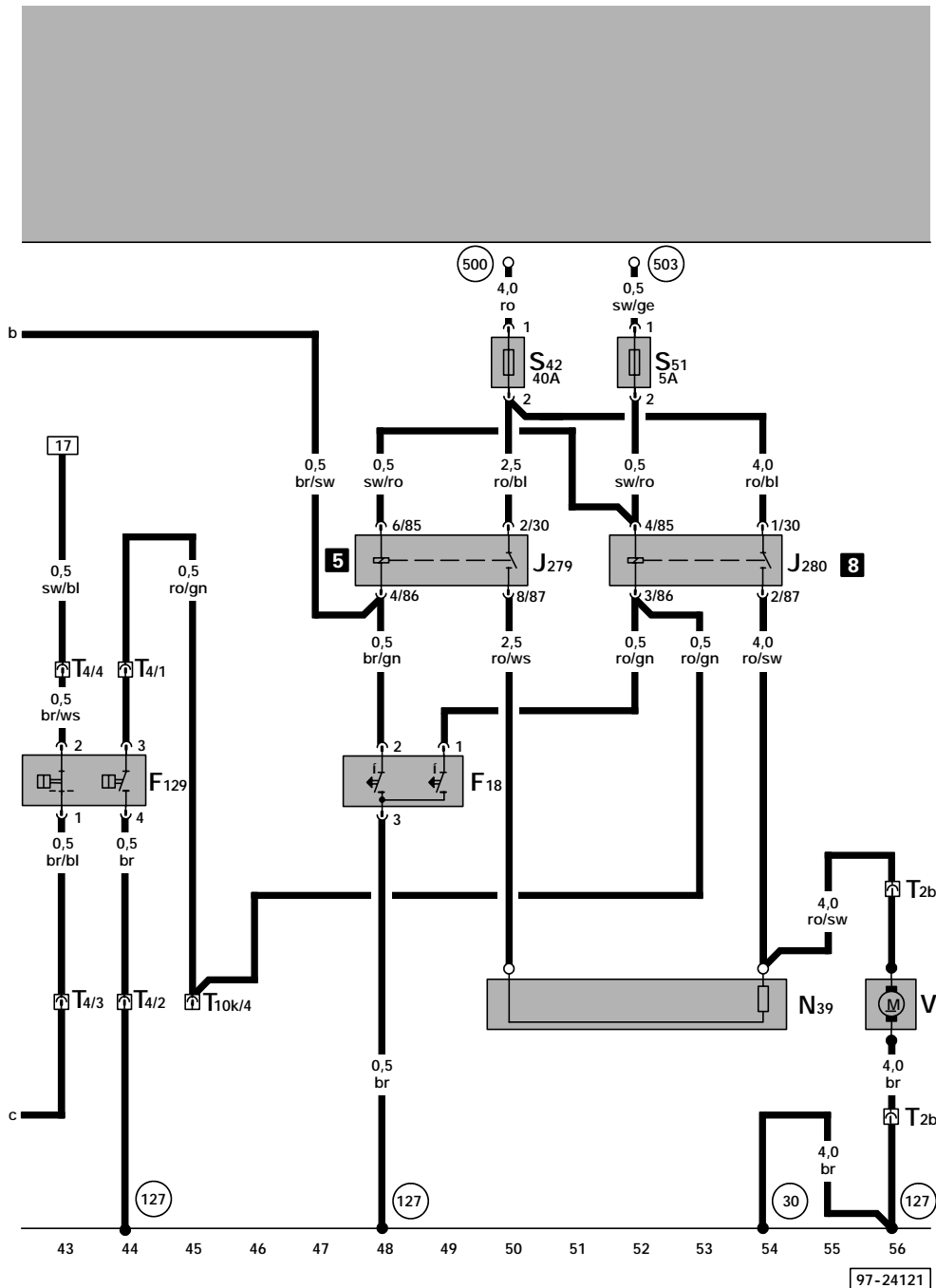

ws = white
 sw = black
 ro = red
 br = brown
 gn = green
 bl = blue
 gr = grey
 li = violet
 ge = yellow

- F18 - Coolant Fan Control (FC) Thermal Switch
- F129 - A/C Pressure Switch
- J279 - First Speed Coolant Fan Control (FC) Relay, on eightfold auxiliary relay panel, production control number (214)
- J280 - Second Speed Coolant Fan Control (FC) Relay, on eightfold auxiliary relay panel, production control number (213)
- N39 - Coolant Fan Control (FC) Series Resistance, below side member, left
- S42 - Coolant Fan Fuse, on eightfold auxiliary relay panel
- S51 - Coolant Fan Fuse, on eightfold auxiliary relay panel
- T2b - Double Connector, in engine compartment, left front

- T4 - 4-Pin Connector, in engine compartment, left front
- T10k - 10-Pin Connector, grey, connector station A-pillar, left
- V7 - Coolant Fan

- (30) - Ground connection -1-, beside fuse/relay panel
- (127) - Ground connection -1-, in A/C compressor wiring harness
- (500) - Screw connection -1- (30), on relay panel
- (503) - Screw Connection (75x), on relay panel