

## Brake Pads - Vehicles With: High Performance Brakes, VIN Range: G00442->G45703 (70.40.02)

### Removal

1. Raise front of vehicle and support on stands.
2. Remove front wheels.
3. **CAUTION: Remove [brake fluid](#) spillage immediately from paint work, with clean water. Loosen brake fluid reservoir-cap.**

Position a cloth around the reservoir to collect any fluid spillage.

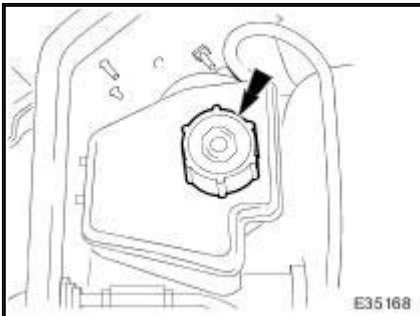

Zoom

Sized for Print

4. Remove brake pads from caliper.
  - 1) Remove 'R' clips.
  - 2) Withdraw pins from caliper.
  - 3) Remove anti-rattle spring.
  - 4) Discard brake pads.

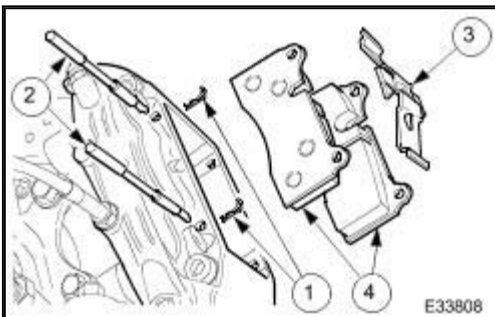

Zoom

Sized for Print

5. Clean all mating surfaces and remove brake dust, see WARNING above.
6. Repeat above procedure to remove opposite side brake pads.

## Installation

1. **CAUTION: Make sure grease does not contact brake-pad friction surface or brake disc.**

To prevent brake squeal apply grease to the shoulders of the brake-pad back plate.

- Apply a uniform layer of grease to back plate shoulders, making sure the whole shoulder is covered.

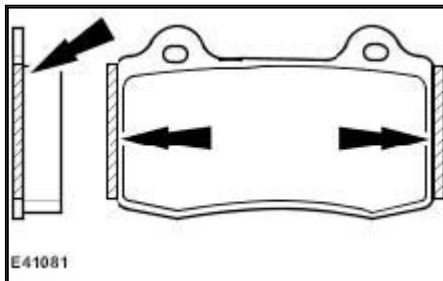

Zoom

Sized for Print

2. **CAUTION: Make sure the brake pads are fitted with the direction arrow following the direction of wheel rotation.**

Make sure the brake pads are fitted with the direction arrow following the direction of wheel rotation.

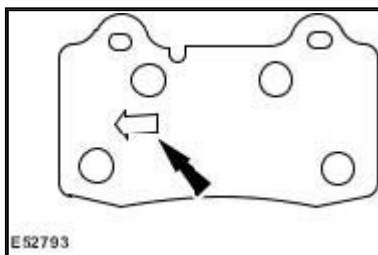

Zoom

Sized for Print

3. **CAUTION: Retracting the caliper piston may cause the fluid reservoir to over-flow. Remove [brake fluid](#) spillage immediately from paint work, with clean water.**

**CAUTION: Make sure the brake pads are installed to the correct orientation.**

**CAUTION: Make sure the brake pads are fitted with the direction arrow following the direction of wheel rotation.**

**CAUTION: Note condition of pins and 'R' clips and replace if necessary.**

Install brake pads into caliper.

- Slowly retract caliper pistons into caliper.
- 2) Install pads.
  - 3) Position anti-rattle spring.
  - 4) Install pins.
  - 5) Install 'R' clips.

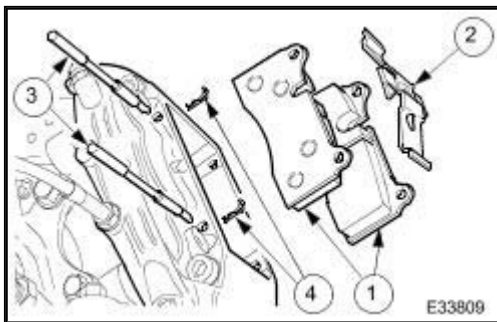

Zoom

Sized for Print

4. Repeat above procedure to install opposite side brake pads.
5. Fit wheels.
6. Remove stands and lower vehicle.
7. **CAUTION: Remove [brake fluid](#) spillage immediately from paint work, with clean water. Check brake fluid level.**

Check [brake fluid](#) level is at the maximum mark.

- Remove cloth.
- Fit cap.

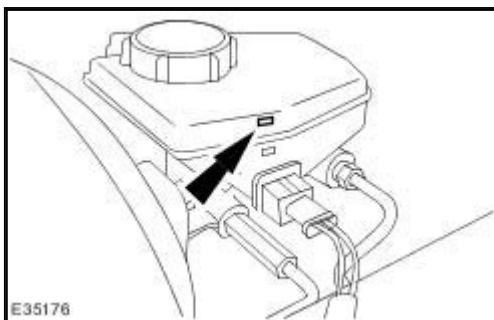

Zoom

Sized for Print

8. Remove paint work protection covers, and close engine compartment.
9. Start the engine and repeatedly press the brake pedal until brake pressure is evident.