

00-012

June 26, 2001

Applies To:

1996-00 Civic - See VEHICLES AFFECTED

1997-99 CR-V - See VEHICLES AFFECTED

Harsh Shifting Automatic Transmission

(Supersedes 00-012, dated June 20, 2000)

Updated information is shown by asterisks and black bars.

SYMPTOM

The transmission shifts harshly, or it may stay in first gear. The harsh shifting is more noticeable on the 1-2 and 2-3 upshifts under light throttle. It is not affected by operating temperature. The [MIL](#) may be on with DTC P0730 or P0715 stored.

PROBABLE CAUSE

Contamination of the linear solenoid and its associated passages inside the transmission, or a broken spring internal to the transmission.

1996-99 Civic - All with A/T (except HX with CVT)
2000 Civic:
4-door DX, LX - From VIN 1HGEJ6...YL000001 thru 1HGEJ6...YL019847
4-door DX, LX - From VIN 2HGEJ6...YH500001 thru 2HGEJ6...YH539903
4-door EX - From VIN 1HGEJ8...YL000001 thru 1HGEJ8...YL020169
4-door EX - From VIN 2HGEJ8...YH500001 thru 2HGEJ8...YH522686
2-door DX - From VIN 1HGEJ6...YL000001 thru 1HGEJ6...YL025993
2-door EX - From VIN 1HGEJ8...YL000001 thru 1HGEJ8...YL026389
3-door CX, DX - From VIN 2HGEJ6...YH100001 thru 2HGEJ6...YH102557
1997-99 CR-V - All

Zoom

Sized for Print

VEHICLES AFFECTED

CORRECTIVE ACTION

Flush the transmission with Genuine Honda ATF-Z1, then replace the linear solenoid. If shift feel is not affected, replace the transmission.

PARTS INFORMATION

Linear Solenoid Assembly: P/N 28250-P4R-315, H/C 5317219

Drain Bolt Washer: P/N 90471-PX4-000, H/C 3300936

REQUIRED MATERIALS

Genuine Honda ATF-Z1: P/N 08200-9001, H/C 6512628

Civic and 2WD CR-V - 11.6 quarts required
 4WD CR-V - 12.4 quarts required

WARRANTY CLAIM INFORMATION

Template ID 00-012C: For 1996-97 Civic and 1997 CR-V

OP#	Description	FRT	Template ID
222173	Replace linear solenoid	0.3	00-012C
221001	Flush transmission	0.8	
222092	Test-drive	0.3	

Failed Part: P/N 28250-P4R-315
 H/C 5317219

Defect Code: 814

Contention Code: K49

Skill Level: Repair Technician

Template ID 00-012D: For 1998-00 Civic and 1998-99 CR-V

OP#	Description	FRT	Template ID
222133	Replace linear solenoid	0.3	00-012D
221001	Flush transmission	0.8	
222092	Test-drive	0.3	

Failed Part: P/N 28250-P4R-315
 H/C 5317219

Defect Code: 031

Contention Code: B99

Skill Level: Repair Technician

If you replace the transmission, refer to service bulletin 98-061, *Automatic Transmission In-Warranty Exchange Program*, for flat rate and warranty claim information.

Zoom

Sized for Print

In warranty:

The normal warranty applies.

Out of warranty:

Any repair performed after warranty expiration may be eligible for goodwill consideration by the District Service Manager or your Zone Office. You must request consideration, and get a decision, before starting work.

REPAIR PROCEDURE

1. Raise the vehicle on a hoist.
2. Drain the transmission. Refill it with Genuine Honda ATF-Z1.
3. Start the engine.
4. With your foot on the brake pedal, shift the transmission to D4
5. Release the brake pedal. Press on the accelerator, and bring the speedometer up to 50 mph. Make sure the transmission shifts through the first three lower gears and into fourth, and that the torque converter locks up.
6. Apply the brakes to stop the front wheels.
7. Shift to reverse, and then to neutral.
8. Repeat the shifting procedure (steps 4 through 7) four more times.
9. Turn off the engine.
10. Repeat the above drain, refill, and shifting procedure (steps 2 through 9) two more times.
11. Drain the transmission. Reinstall the drain bolt with a new washer. Refill the transmission with Genuine Honda ATF-Z1.

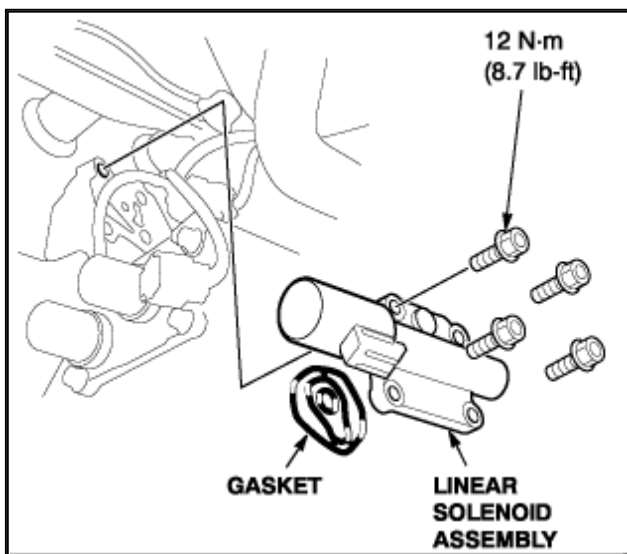

Zoom

Sized for Print

12. Disconnect the linear solenoid electrical connector. Remove the mounting bolts, then remove the linear solenoid.

13. Inspect the linear solenoid mounting surface on the transmission. Remove any contamination.
14. Install the new linear solenoid. Reconnect the electrical connector.
15. Use the PGM Tester to erase any DTCs in the powertrain control module (PCM).
- *16. Test-drive the vehicle to check the shift feel. If it still shifts harshly, install a remanufactured transmission.*