



# SERVICE BULLETIN

Classification: EC01-028a	Reference: NTB01-074a	Date March 19, 2002
------------------------------	--------------------------	------------------------

## 2002 ALTIMA AND SENTRA; MIL "ON" AND DTC P0340 (CAMSHAFT POSITION SENSOR CODE) STORED

This bulletin amends NTB01-074. This version includes additional Model and Model Year application. Please discard all paper copies of the earlier bulletin.

- APPLIED VEHICLE(S):** 2002 Altima (L31) with 2.5 Liter Engine (QR25DE) Only  
2002 Sentra (B15) with 2.5 Liter Engine (QR25DE) Only
- APPLIED VIN(S):** Altima, built before 1N4AL11D(\*)2C127700  
Sentra, built before 3N1AB51D(\*)2L700378
- APPLIED DATE(S):** Altima, built before October 3, 2001  
Sentra, built before October 12, 2001
- APPLIED ENGINE(S)** Built before QR25-121950 Z

### SERVICE INFORMATION

If an applied vehicle exhibits one or more of the following symptoms:

- MIL "ON" with DTC P0340 (Camshaft Position Sensor) stored in Self Diagnosis results,
- Engine stumbles momentarily during cruise condition,
- Engine stops running at idle,

The cause of this incident may be the ignition coils. A new resistor assembly (located inside the ignition coil tube) is available to repair the described symptoms, if they should occur.

### SERVICE PROCEDURE

1. Verify that the vehicle has one or more of the symptoms listed above in the Service Information.
2. Remove all four ignition coils. Refer to the appropriate 2002 Service Manual for removal procedure of the ignition coils (page EM-26 for Altima, page EM-106 for Sentra).

3. Install the new resistor assembly in all four ignition coil tubes as follows:

- A. Pull the rubber boot away from the ignition coil. Then, twist and pull the ignition coil tube from the ignition coil to separate them (see Figure 1).

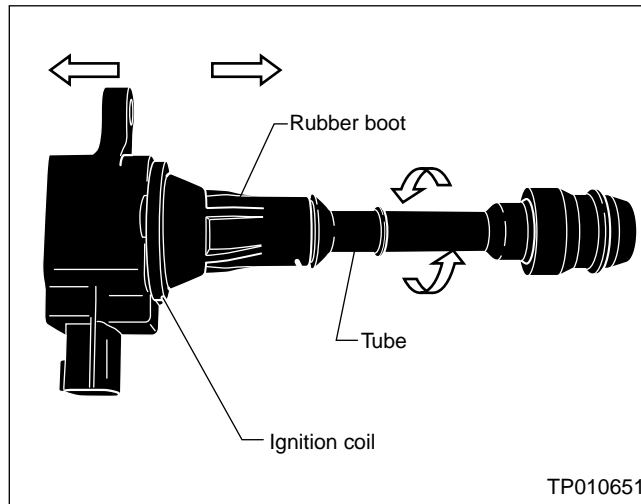

Figure 1

- B. Remove the spring from the ignition coil tube and discard. Insert the new resistor assembly into the ignition coil tube exactly as shown in Figure 2 below.

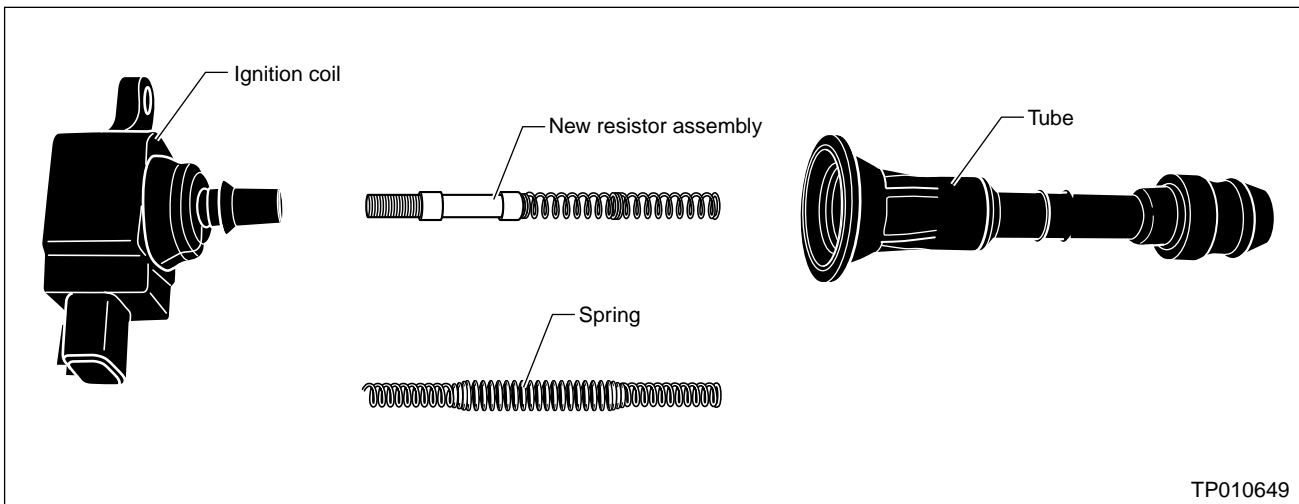

Figure 2

C. Assemble the ignition coil tube to the ignition coil.

- Rotate the tube while pressing onto the coil.
- A "pop" sound will be heard when the rubber boot is seated correctly to the ignition coil.
- Ensure there are no gaps and bulges between the coil body and the rubber boot (see Figure 3).

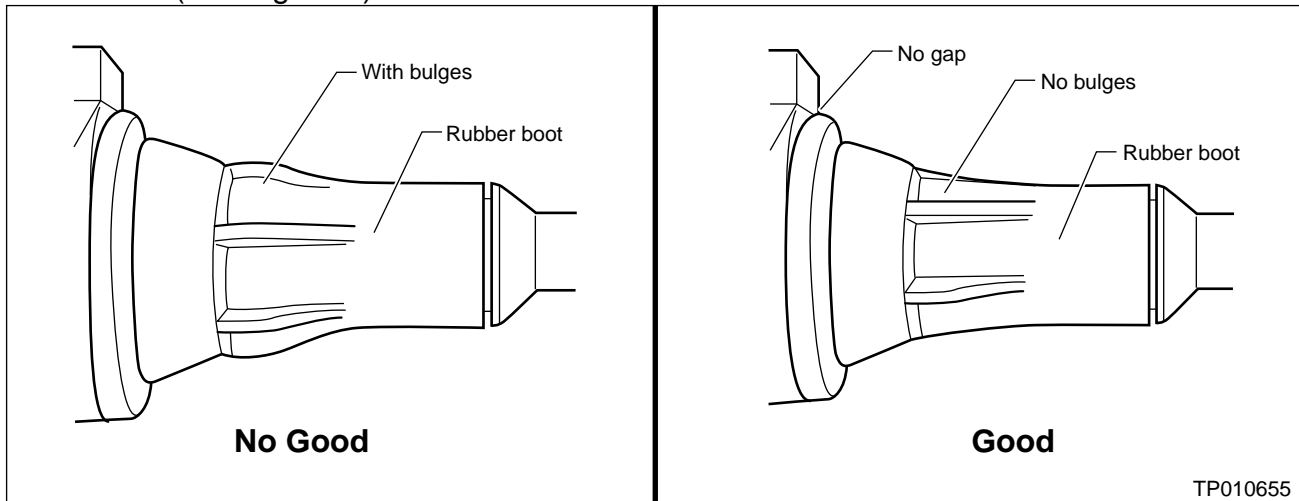

Figure 3

4. Re-install the ignition coils with the new resistor assembly to the engine. Refer to the appropriate 2002 Service Manual for installation procedure of ignition coils (page EM-26 for Altima, page EM-106 for Sentra).
5. Erase the DTC from Engine Self Diagnosis.
6. Test drive vehicle and re-check Self Diagnosis results using CONSULT-II to confirm the incident has been resolved.

**PARTS INFORMATION**

DESCRIPTION	PART #	QUANTITY
Spring Kit	22468-6N225	1

**CLAIMS INFORMATION**

DESCRIPTION	PFP	OP CODE	SYM	DIA	FRT
R&R All 4 Coils & RPL Resistor Assys	22468-6N225	GX07AA	(1)	32	0.5 hrs
Diagnosis – DTC P0340		EE24AA			(2)

1. HD, AB or AC as indicated by the customer's complaint.
2. Please reference the current Nissan "Warranty Flat Rate Manual" and use the indicated FRT.

