

SPARK PLUG REMOVAL INSTRUCTIONS - 5.4 3V

TECHNICAL SERVICE BULLETIN

Reference Number(s): 06-15-2, Date of Issue: August 7, 2006

FORD: 2004-2005 F-150; 2005 Expedition, F-Super Duty

LINCOLN: 2005 Navigator

Superseded Bulletin(s): 06-5-9, Date of Issue: March 20, 2006

ISSUE

NOTE: This article supersedes TSB 06-5-9 to update the vehicle lines and model years.

Some 2004-2005 F-150 and 2005 F-Super Duty, Expedition, and Navigator vehicles with a 5.4L 3-valve engine may experience difficulty with spark plug removal which may cause damage to the spark plug and leave part of the spark plug in the cylinder head.

ACTION

Refer to the following Service Procedure for techniques to remove the spark plugs and extract broken spark plugs.

SERVICE PROCEDURE

GENERAL SPARK PLUG REMOVAL

To remove spark plugs without damage, it is necessary to adhere exactly to this procedure before removal is attempted.

1. Make sure the engine is warm (hand touch after cooling down).

CAUTION: DO NOT REMOVE PLUGS WHEN THE ENGINE IS EXTREMELY HOT OR COLD SOAKED. THIS INCREASES THE CHANCE THE THREADS COULD BE DAMAGED.

CAUTION: BE SURE TO WEAR SAFETY GLASSES FOR STEP 2.

2. Remove the coil-on-plug assemblies and thoroughly blow out the spark plug wells and surrounding valve cover area with compressed air.
3. Back out the spark plugs, no more than 1/8 to 1/4 of a turn. Apply penetrating oil (AeroKroil or equivalent) and fill the spark plug well just above where the jamb nut hex sits. A minimum period of 5 to 10 minutes of soak time is required. The penetrating oil will wick down to the ground electrode shield in this time. DO NOT WORK the spark plug back and forth at this point.

CAUTION: EXCESSIVE PENETRANT, OR REPEATING THE PROCESS SEVERAL TIMES WITH TOO MUCH FLUID, COULD INTRODUCE ENOUGH LIQUID VOLUME TO HYDRO-LOCK THE ENGINE.

CAUTION: DO NOT USE AIR OR POWER TOOLS FOR PLUG REMOVAL. THE PLUG MUST ONLY BE REMOVED WITH HAND TOOLS.

4. Slowly turn the spark plug out. Some screeching and high effort may be noticed but, not in every case. The expected removal torque is about 33 lb-ft (45 N.m) but should decrease on the way out. If it is higher, try turning the spark plug back in a half turn, then back out again. If the turning torque still seems high, repeat the back and forth rotation along with some penetrating oil to reduce turning effort.

SEPARATED/BROKEN SPARK PLUG REMOVAL

If the plug does come apart even after following the General Spark Plug Removal Procedure, it will break in one of two modes:

Mode 1: The ground electrode shield is left behind as an empty shell ([Fig. 1](#)).

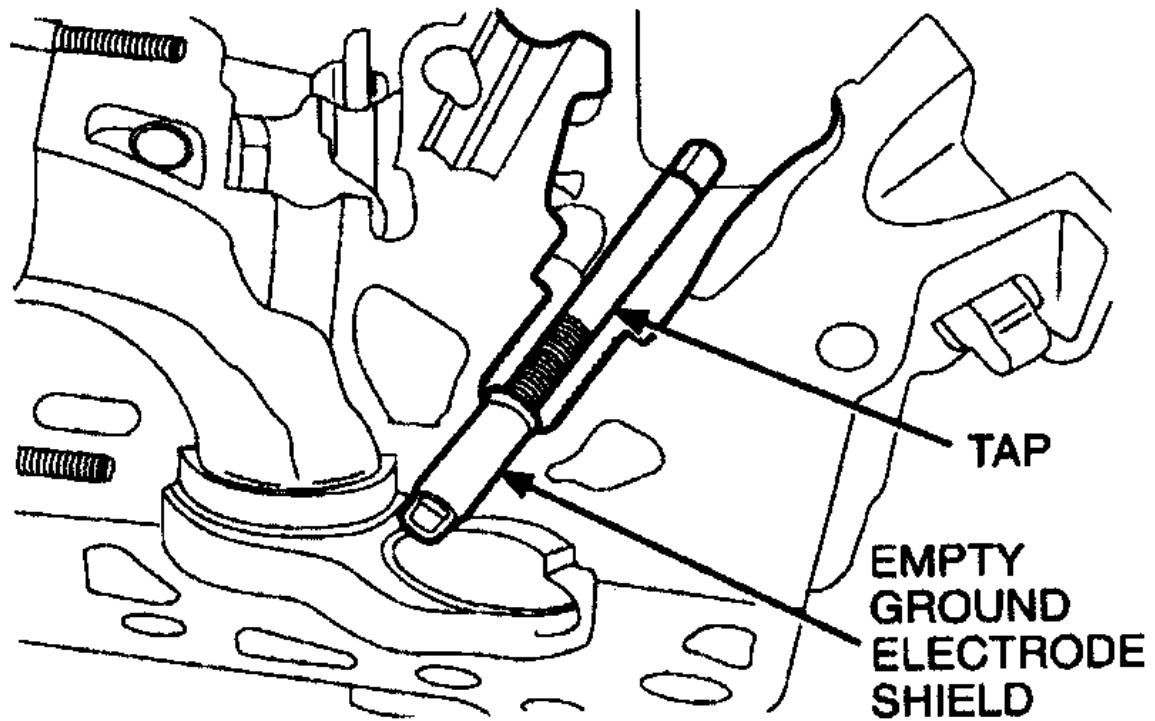

G00428840

Fig. 1: Ground Electrode Shield Left Behind As Empty Shell

Mode 2: The porcelain center and ground electrode shield is left behind and only the upper jamb nut comes out. In this case more soaking is required and long-reach nose pliers should be used to grasp and remove the porcelain center from the ground electrode shield ([Fig. 2](#)).

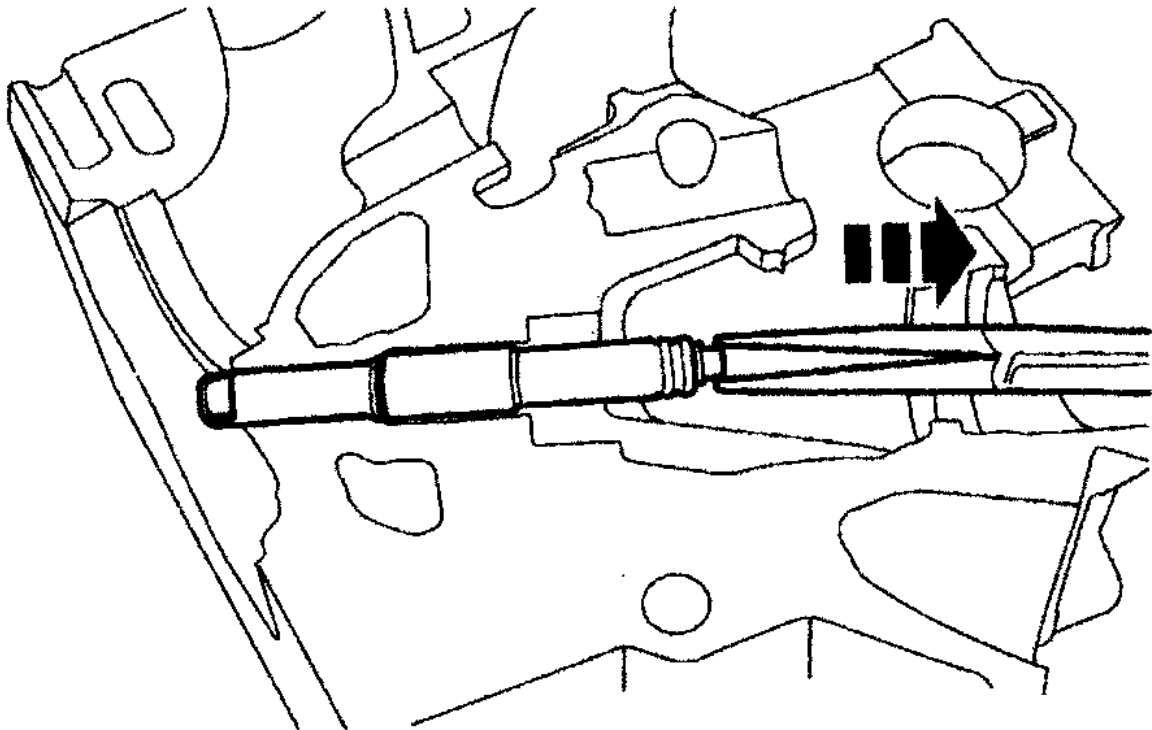

G00428841

Fig. 2: Removing Porcelain Center From Ground Electrode Shield

Once there is only an empty ground electrode shield left in the cylinder head, perform the following steps to remove the shield using Rotunda Special Service Tool 303-1203 ([Fig. 3](#)).

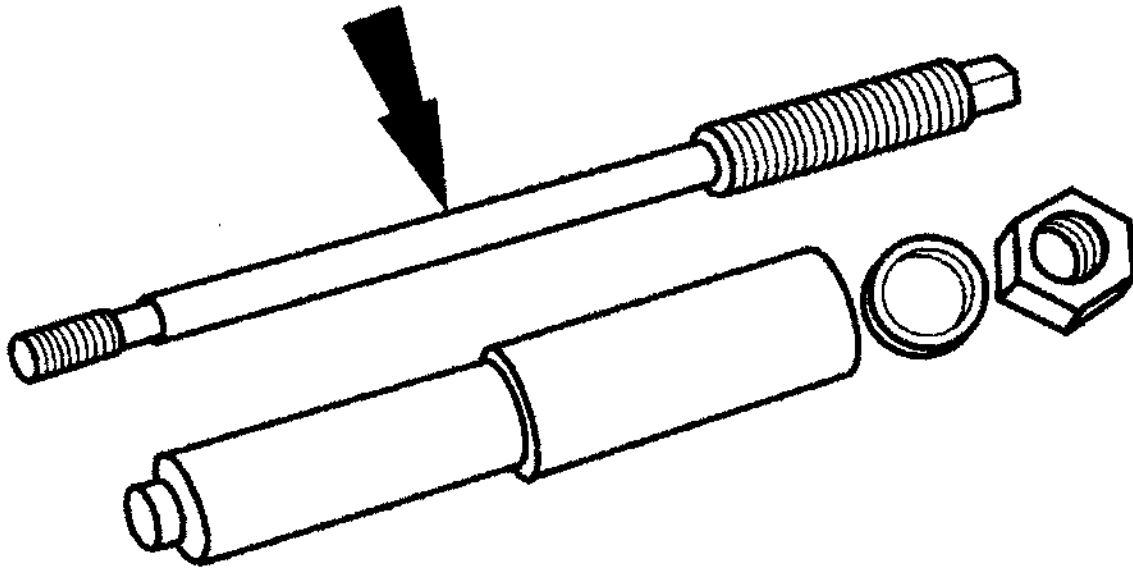

G00428842

Fig. 3: Rotunda Special Service Tool 303-1203

NOTE: THIS TOOL IS ONLY DESIGNED TO WORK WITH AN EMPTY GROUND ELECTRODE SHIELD. IF THE SPARK PLUG CAME APART IN MODE 2, THE PORCELAIN CENTER MUST BE REMOVED PRIOR TO FOLLOWING THESE STEPS.

1. The combustion chamber must be protected from contamination during the extraction process by using a modified vacuum cap (382444-S) as a stopper-type plug. This is because the remaining ground electrode shield will be thread-tapped, so the cap is needed to prevent thread chips from falling into the cylinder bore. Cut a vacuum cap to a 3/8" (10 mm) length for each ground electrode shield that needs to be removed.
2. Install the modified cap with a long drill bit or suitable wire ([Fig. 4](#)), sized for the internal diameter of the cap. The rubber cap should bottom-out on the electrode strap of the ground electrode shield once installed.

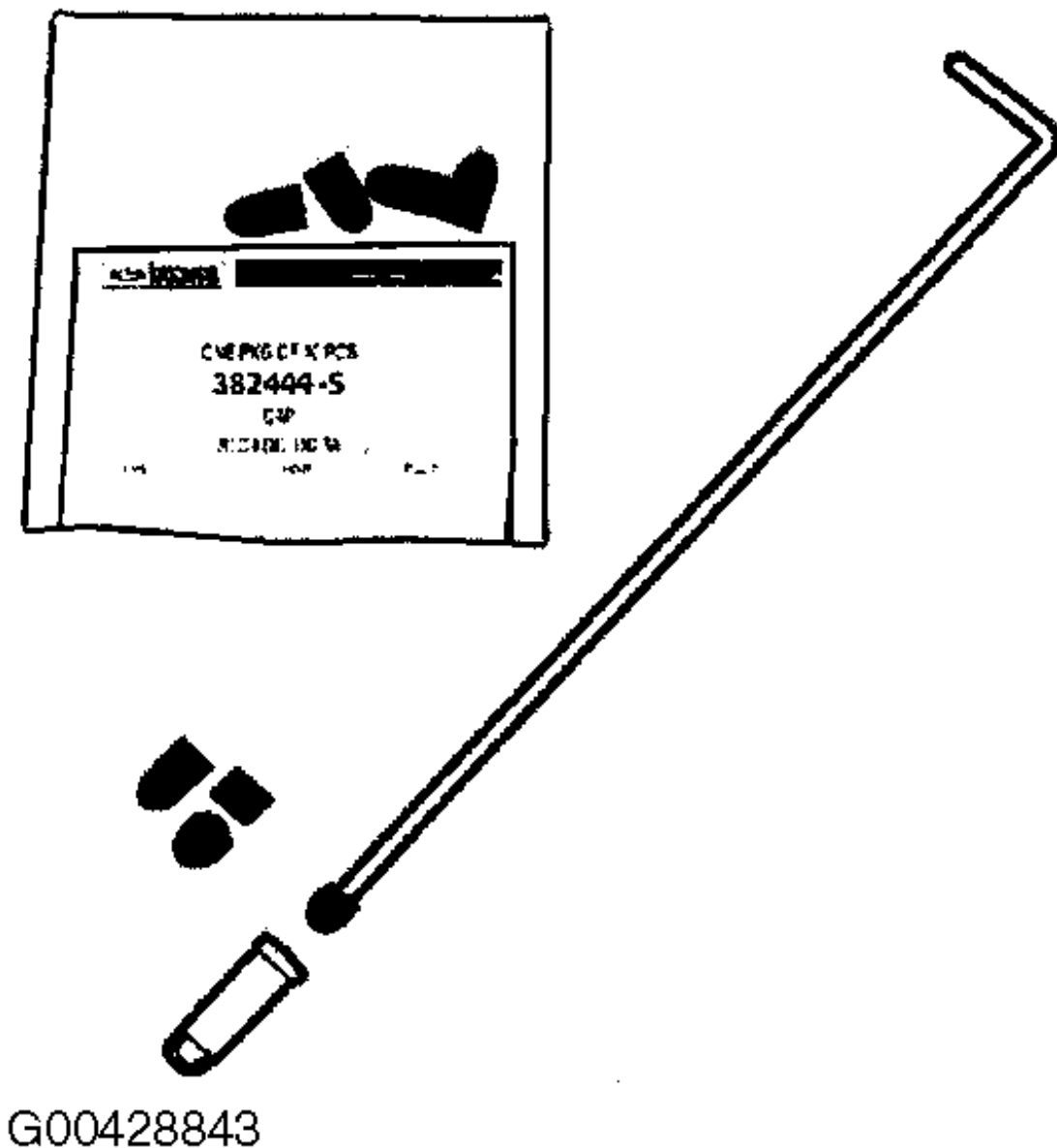
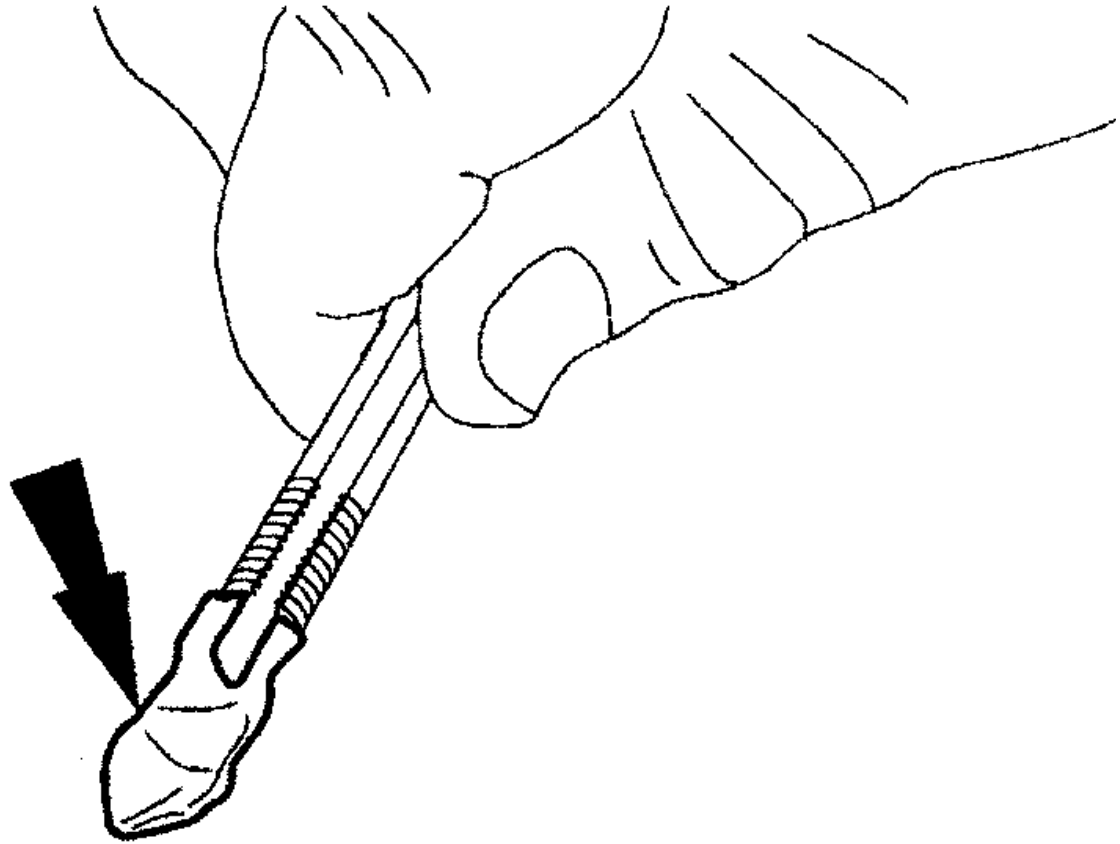

Fig. 4: Installing Modified Vacuum Cap

3. Thread-tap the ground electrode shield using a 9.0 x 1.0 mm "plug" tap (tap profile is about 3-4 reduced diameter threads on the tip end).
 - a. Coat the end of the tap with general purpose grease as shown in [Fig. 5](#).



G00428844

Fig. 5: Coating Tap With Grease

- b. Turn the tap about 3 to 4 turns into the ground electrode shield once the tap begins to cut. As the shield is tapped, for every 1/2 turn, the tap should be backed up 1/8 turn to "break chips" and prevent any cut material from coiling-up and laying in the spark plug well. All of the thread chips will embed in the grease pack or drop inside the vacuum cap when following this procedure. A suitably sized tap wrench of about 7-9 inches in handle length will aid in reaching down the well. If not available, use an 8 point socket with a ratchet and drive extension. Keep the shank aligned with the axis of the spark plug bore cavity to prevent possible thread bore damage. Use care not to damage any spark plug threads on the way in.

CAUTION: DO NOT ATTEMPT TO REMOVE THE GROUND ELECTRODE SHIELD WITH THE TAP AND WRENCH. THE TAP MAY BREAK IF THIS IS ATTEMPTED.

- c. Carefully back out the tap while maintaining the residual grease coat on the tap which contains some chips. Take care not to touch the sides of the spark plug well bore during removal.
4. Once the ground electrode shield is tapped, thread Rotunda Special Service Tool 303-1203 into the ground electrode shield to extract it from the spark plug well and encapsulate any remaining chips from falling into the combustion chamber.

NOTE: SEE [Fig. 6](#) FOR DETAILS OF THE TOOL AS INSTALLED IN THE HEAD.

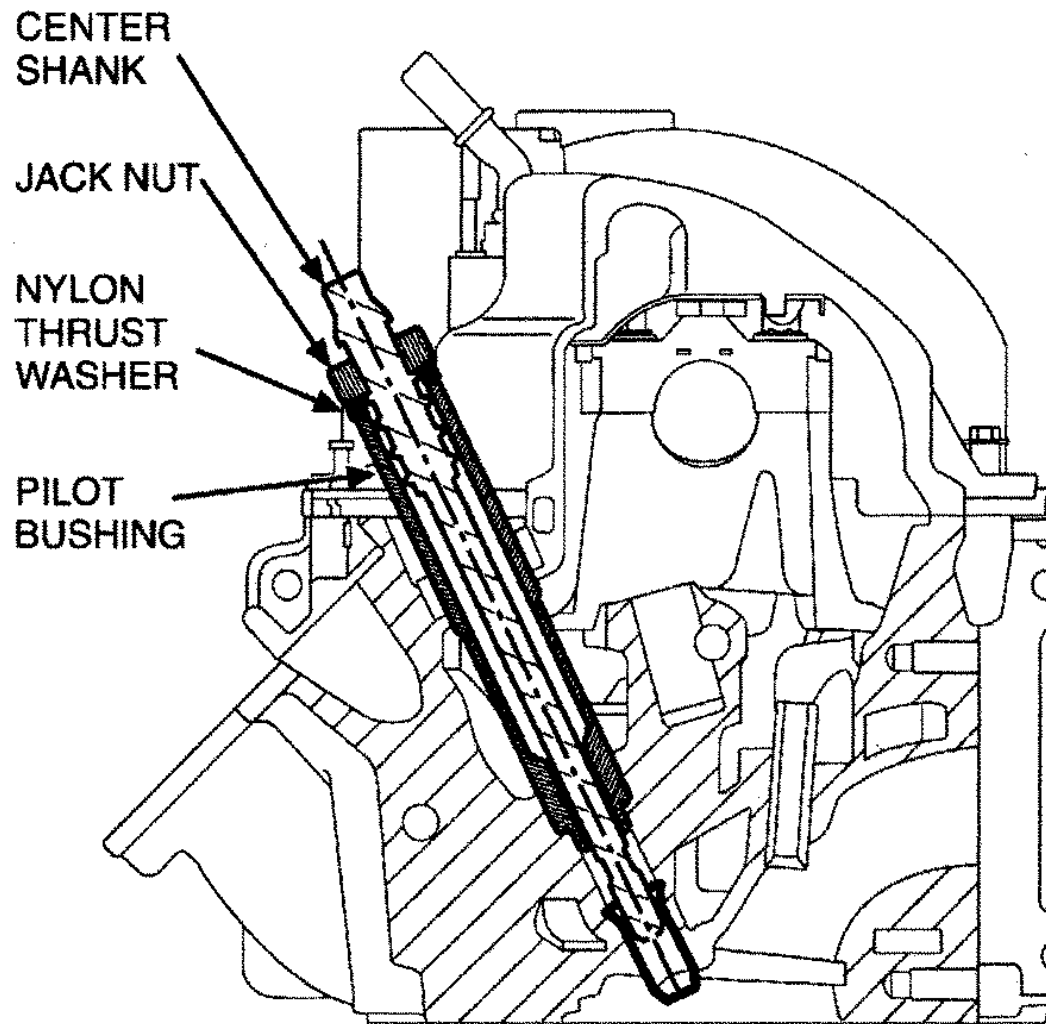

NOTE: VALVE COVER REMOVED ONLY FOR ILLUSTRATION CLARITY

GROUND ELECTRODE SHIELD AS SHOWN PROTRUDING INTO THE COMBUSTION CHAMBER

G00428845

Fig. 6: Details Of Tool As Installed In Head

- a. Install the stepped end of the tool pilot bushing into the spark plug well ensuring it bottoms out.
- b. Screw the center shank into the ground electrode shield. Do not over tighten the shank, to prevent thread stripping.

- c. Install the nylon washer and jack nut until finger tight.
- d. Turn the jack nut with a socket and 3/8" drive ratchet until the ground electrode is freed from the cavity and withdraw the tool assembly. Several turns of the nut are required. Upon removal, any remaining chips not caught earlier by the tap grease will be captured by the rubber plug sitting at the bottom of the ground electrode shield.

NOTE: ONCE THE SPARK PLUGS HAVE ALL BEEN REMOVED, NEW PLUGS SHOULD BE INSTALLED USING A FILM COATING OF MOTORCRAFT HIGH TEMPERATURE NICKEL ANTI-SEIZE LUBRICANT (XL-2) ON THE GROUND ELECTRODE SHIELD OF THE NEW SPARK PLUG ([Fig. 7](#)). DO NOT COAT THE ELECTRODE STRAP OR THE PLUG WILL MISFIRE. THE NEW PLUGS SHOULD BE INSTALLED WITH NO LUBRICANT ON THE THREADS AND TORQUED TO SPECIFICATION, 25 LB-FT (34 N.m).

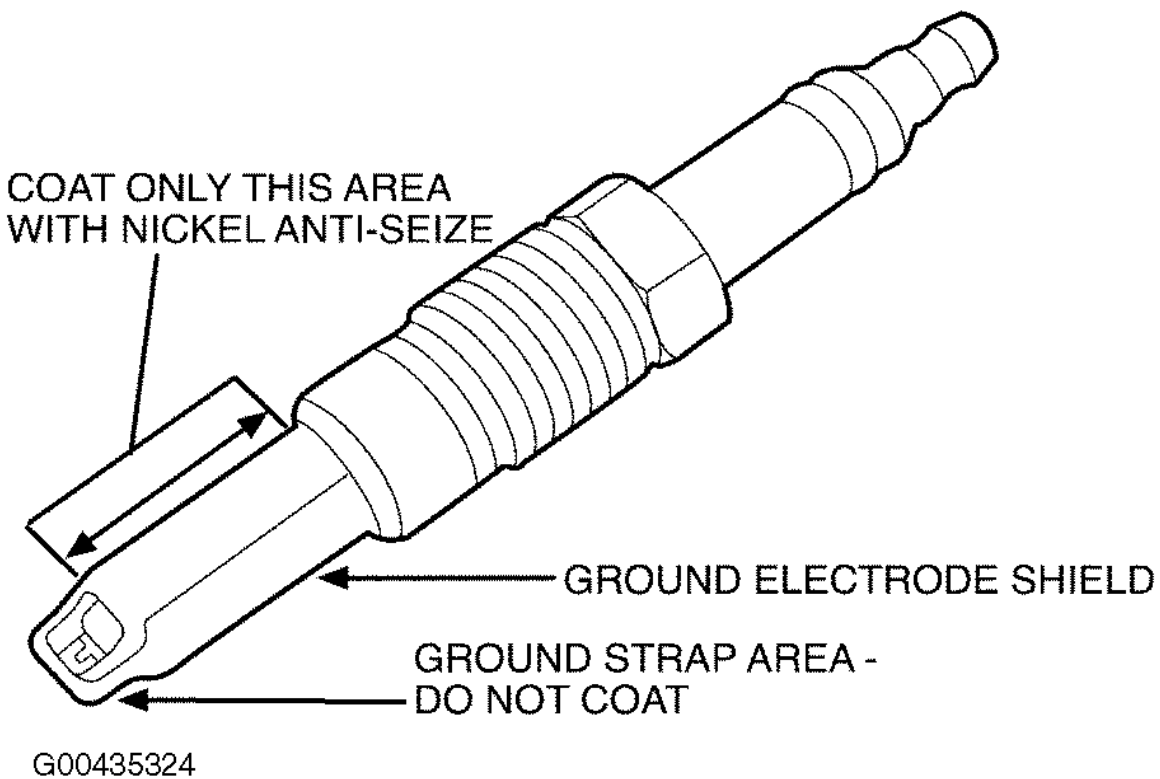

Fig. 7: Anti-Seize Lubricant Application To Ground Electrode Shield

PARTS INFORMATION

PARTS INFORMATION

--	--

Part Number	Part Name
AeroKroil	Obtain through www.kanolabs.com or by calling 1-800-311-3374 (orange aerosol can)
382444-S	Vacuum Cap
XL-2	Motorcraft High Temperature Nickel Anti-Seize Lubricant

WARRANTY INFORMATION

WARRANTY STATUS: Eligible Under Provisions Of New Vehicle Limited Warranty Coverage And Emissions Warranty Coverage.

WARRANTY INFORMATION

Operation	Description	Time
MT061502	Claim Labor As Actual Time	Actual Time

DEALER CODING

Basic Part No.	Condition Code
12405	01

© 2006 Mitchell Repair Information Co., LLC.