

2003 ODYSSEY - Intake Manifold Removal and Installation

Exploded View-1999-2001 models

Exploded View-2002-2004 models

Removal

1. Remove the intake manifold cover (A) and ignition coil cover(s) (B).

1999-2001 models:

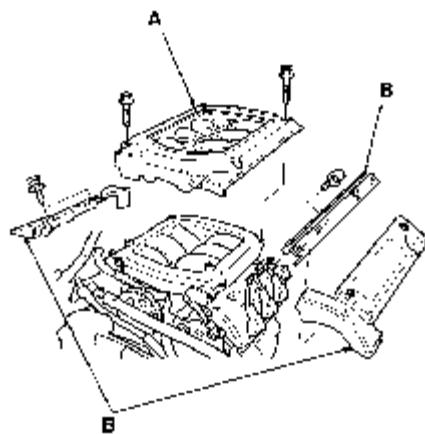

2002-2004 models:

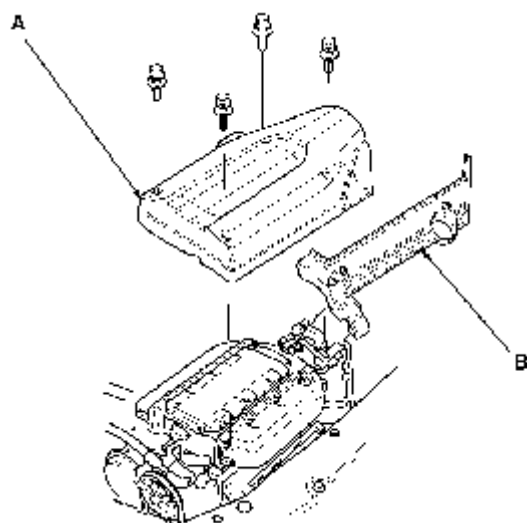

2. Remove the evaporative emission (EVAP) canister hose (A) (1999-2001 models) or vacuum hose (A) (2002-2004 models).
3. Remove the vacuum hose(s) (B) and breather pipe (C), then remove the intake air duct (D).

1999-2001 models:

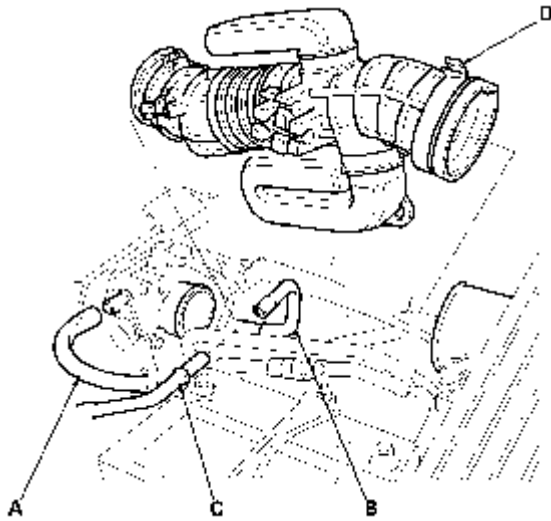

2002-2004 models:

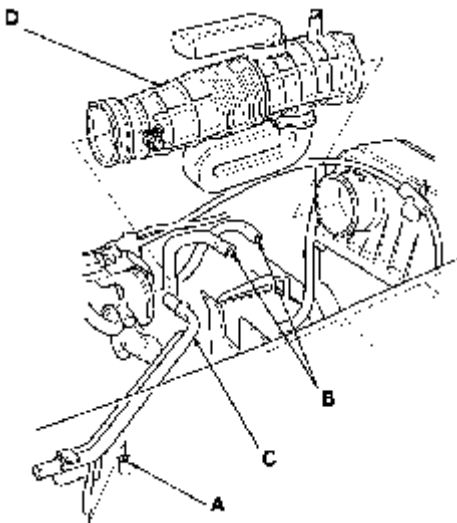

4. Remove the throttle cable (A) and cruise control cable (B) by loosening the locknuts (C), then slip the cable ends out of the accelerator linkage. Take care not to bend the cables when removing them. Always replace any kinked cable with a new one.
5. Remove the engine wire harness connectors and wire harness clamps from the intake manifold.
 - Intake air temperature (IAT) sensor connector
 - Idle air control (IAC) valve connector
 - Throttle position (TP) sensor connector
 - Manifold absolute pressure (MAP) sensor connector
 - Evaporative emission (EVAP) canister purge valve connector (2002-2004 models)

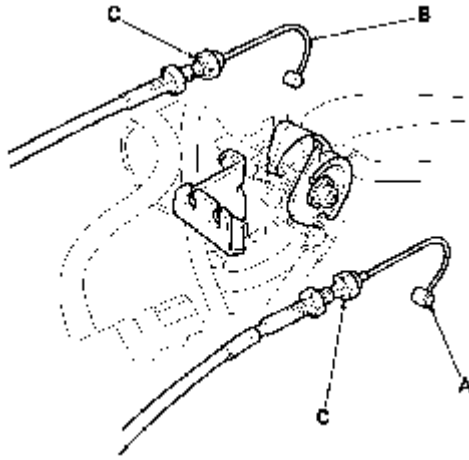

6. Remove the brake booster vacuum hose (A) and positive crankcase ventilation (PCV) hose (B).
7. Remove the vacuum hoses (C) (1999-2001 models).

1999-2001 models:

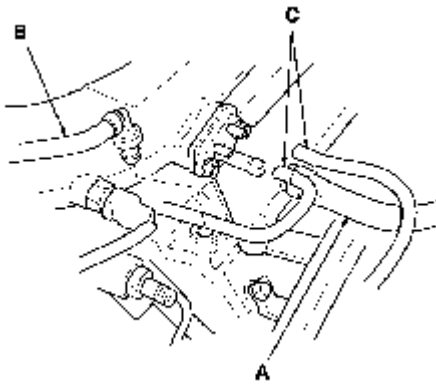

2002-2004 models:

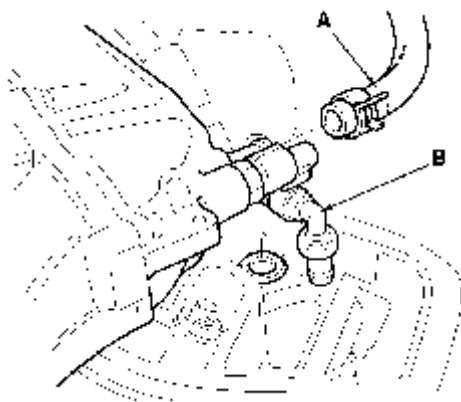

8. Remove the breather hose (A) and water bypass hoses (B), then plug the water bypass hoses.
9. Remove the EVAP canister hose (C) (2002-2004 models).

1999-2001 models:

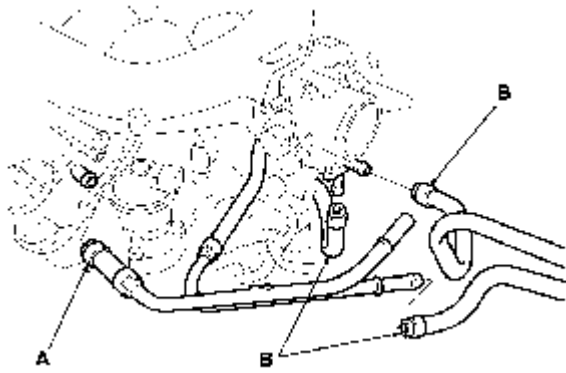

2002-2004 models:

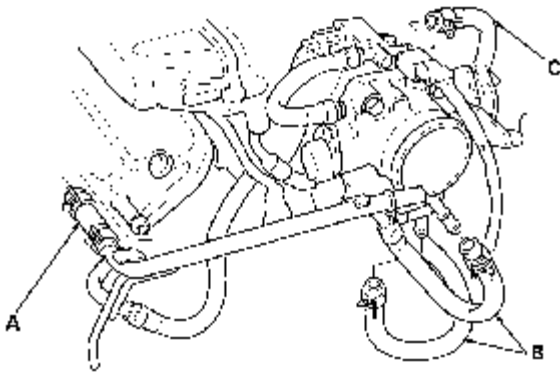

10. Remove the intake manifold (1999-2001 models).

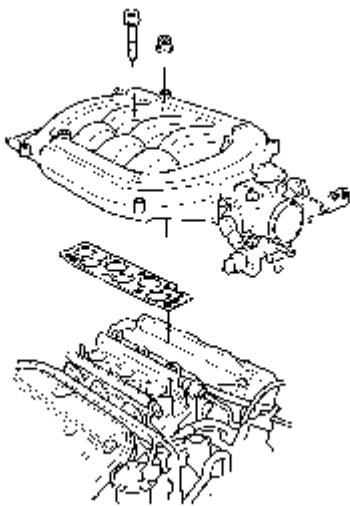

11. Remove the upper cover (A), then remove the intake manifold (B) and spacer (C) (2002-2004 models).

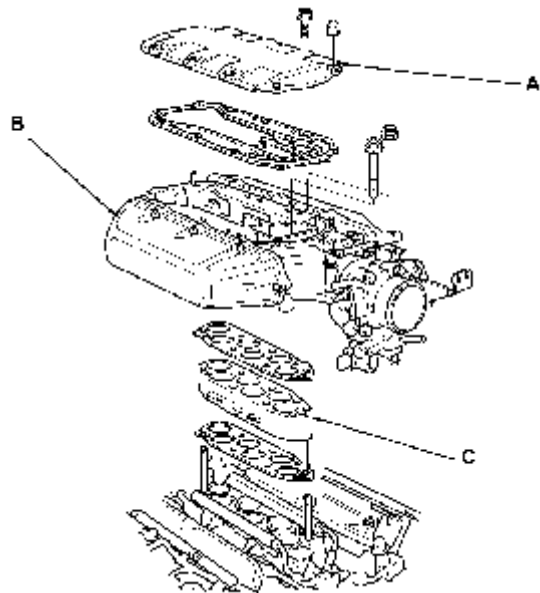

Installation

1. Put the gasket and spacer on the injector base (2002-2004 models).
2. Install the intake manifold. Tighten the bolts and nuts sequentially in two or three steps. Always use a new intake manifold gasket.

1999-2001 models:

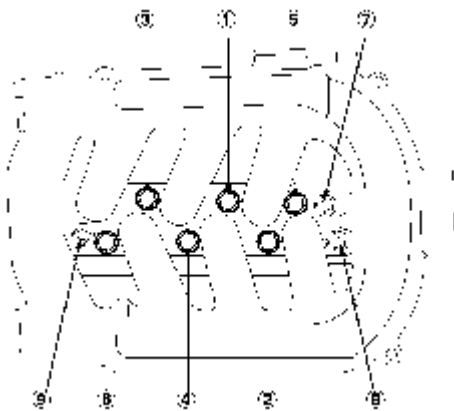

2002-2004 models:

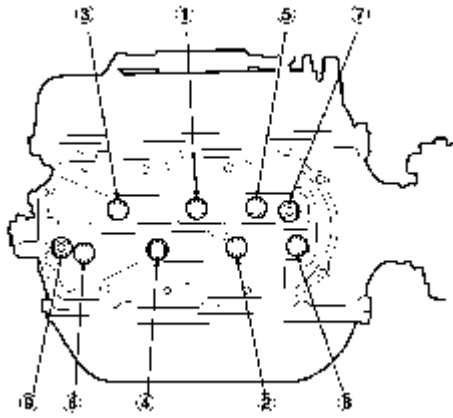

3. Install the upper cover. Tighten the bolts and nuts sequentially in two or three steps. Always use a new intake manifold gasket (2002-2004 Models).

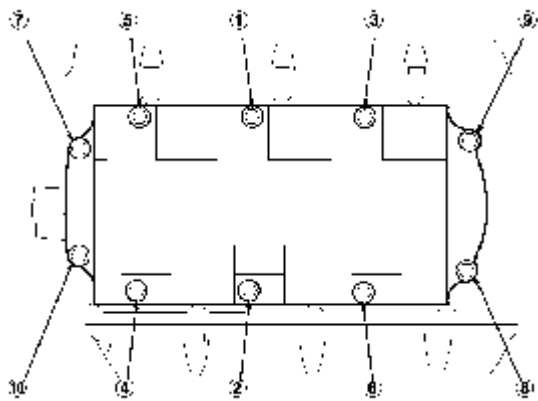

4. Install the breather hose (A) and water bypass hoses (B).
5. Install the EVAP canister hose (C) (2002-2004 models).

1999-2001 models:

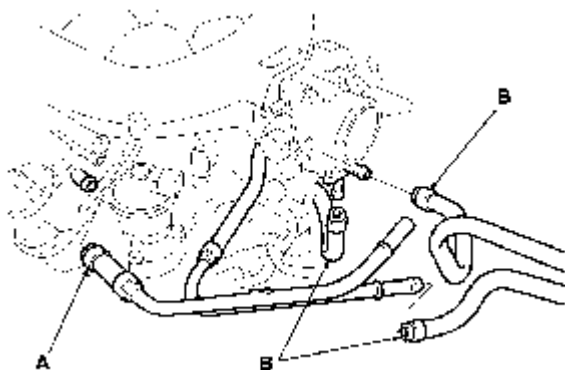

2002-2004 models:

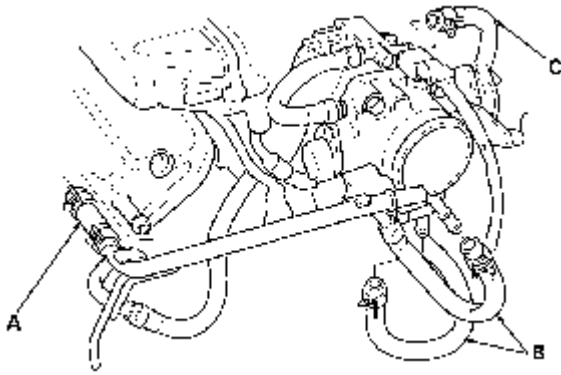

6. Install the brake booster vacuum hose (A) and PCV hose (B).
7. Install the vacuum hoses (C) (1999-2001 models).
8. Install the throttle cable, then adjust the cable.
9. Install the cruise control actuator cable, then adjust the cable.

1999-2001 models:

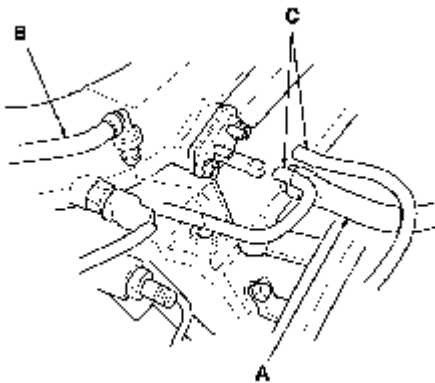

2002-2004 models:

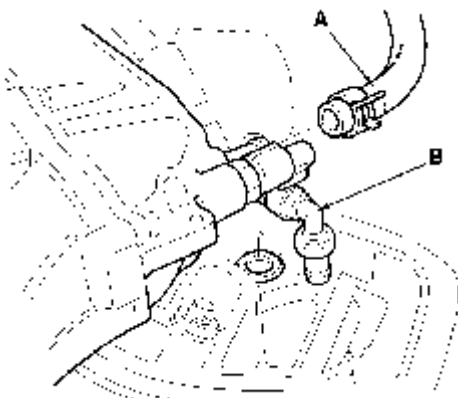

10. Install the intake air duct (A), then install the vacuum hose(s) (B) and breather pipe (C).
11. Install the EVAP canister hose (D) (1999-2001 models) or vacuum hose (D) (2002-2004 models).

1999-2001 models:

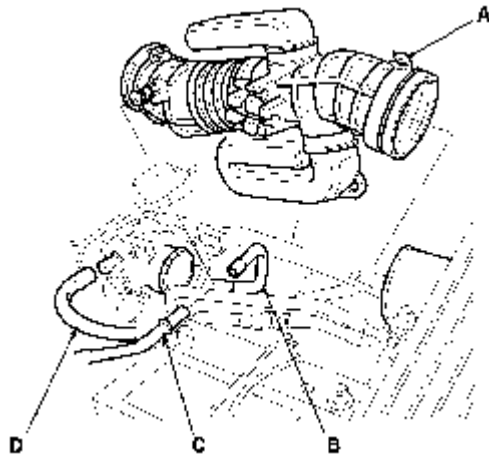

2002-2004 models:

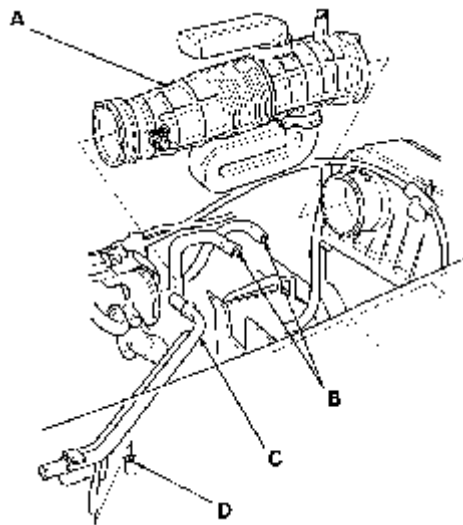

12. Install the ignition coil cover(s) (A) and intake manifold cover (B).
13. Clean up any spilled engine coolant.
14. After installation, check that all tubes, hoses and connectors are installed correctly.
15. Refill the radiator with engine coolant, and bleed air from the cooling system with the heater valve open.

1999-2001 models:

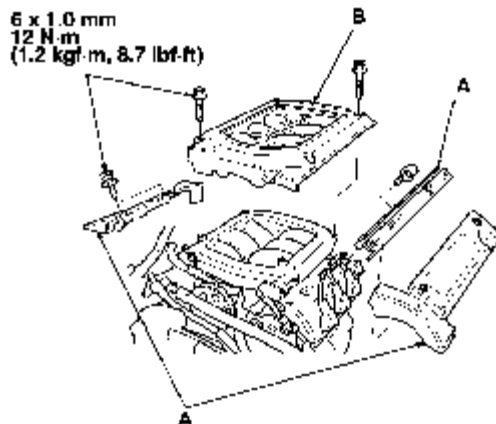

2002-2004 models:

