

2000-2003 MAXIMA DRIVER'S POWER SEAT WILL NOT MOVE FORWARD OR BACKWARD

TECHNICAL SERVICE BULLETIN

Reference Number(s): NTB02-001d, Date of Issue: December 21, 2004
NISSAN: 2000-2003 Maxima (A33)

ARTICLE BEGINNING

APPLIED VEHICLES:

NOTE: This bulletin amends NTB02-001. The Applied Vehicles have been amended. Please discard all paper copies of the earlier versions.

2000-2003 Maxima (A33)

IF YOU CONFIRM:

The driver's seat will not move in the forward or backward direction,

ACTIONS:

1. Confirm this bulletin applies (see steps [1](#) and [2](#) of the Service Procedure).
2. If needed, install the Seat Slide Motor Kit (see Parts Information).

IMPORTANT: DO NOT replace the entire seat adjuster assembly for this incident, if it should occur. This is the ONLY approved repair procedure for this incident. A claim to Nissan for the repair of this incident may be denied if the repair is not performed exactly as outlined in this bulletin.

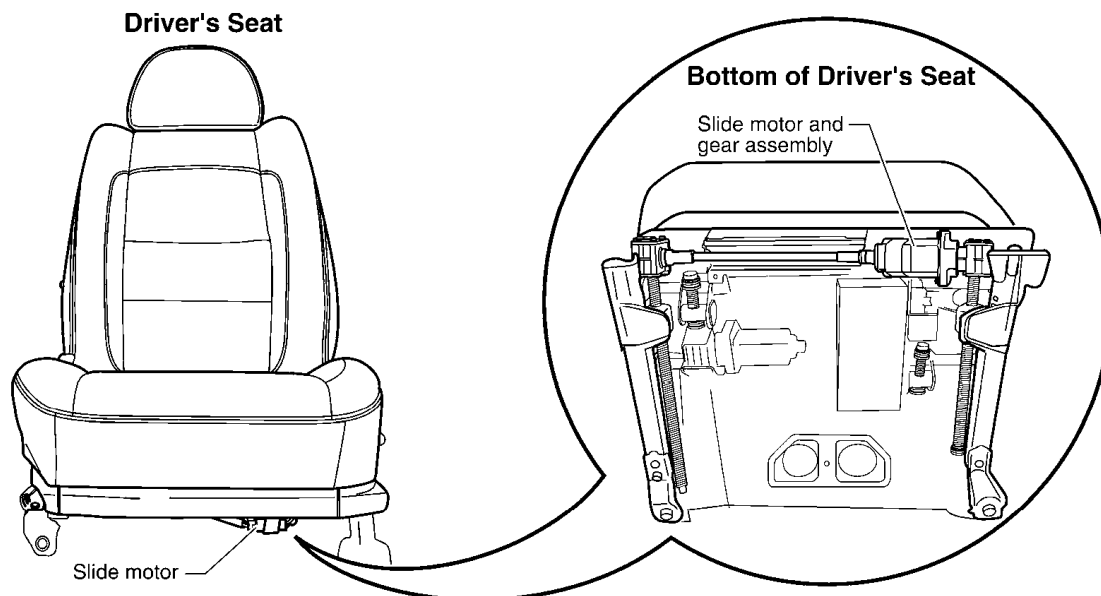

G03360716

Fig. 1: Identifying Driver's Seat Slide Motor And Gear Assembly

IMPORTANT: The purpose of "ACTIONS" (above) is to give you a quick idea of the work you will be performing. You **MUST** closely follow the entire **SERVICE PROCEDURE** as it contains information that is essential to successfully completing this repair.

PARTS INFORMATION

PARTS INFORMATION

DESCRIPTION	PART #	QUANTITY
Seat Slide Motor Kit (for vehicles with ADP)	87562-C9926	1
Seat Slide Motor Kit (for vehicles without ADP)	87562-C9927	1

CLAIMS INFORMATION

NOTE: This is the **ONLY** approved repair procedure for this incident. A claim to Nissan for the repair of this incident may be denied if the repair is not performed exactly as outlined in this bulletin.

Submit a Primary Failed Part (PP) line claim using the following claims coding:

CLAIMS INFORMATION

DESCRIPTION	PFP	OP CODE	SYM	DIA	FRT
RPL Seat slide motor & gear	(1)	VH80AA	ZE	32	(2)

(1) Reference the Parts Information table, above, and use the indicated Seat Slide Motor Kit P/N as

the PFP.

(2) Reference the current Nissan Warranty Flat Rate Manual and use the indicated FRT.

SERVICE PROCEDURE

1. Using the power seat switch, tilt the front edge of the seat bottom all the way up.
2. Check voltage to the seat slide motor as follow:
 - Measure voltage on the harness side between the "BR" and the "W/B" color wires in the seat slide motor connector.
 - See [Fig. 2](#) . For more detailed information, refer to "Power Seat" or "Automatic Drive Positioner" in the EL section of the appropriate Service Manual (ESM).

WARNING: When checking the power seat slide motor circuit, do not confuse its black connector with the side air bag module yellow connector.

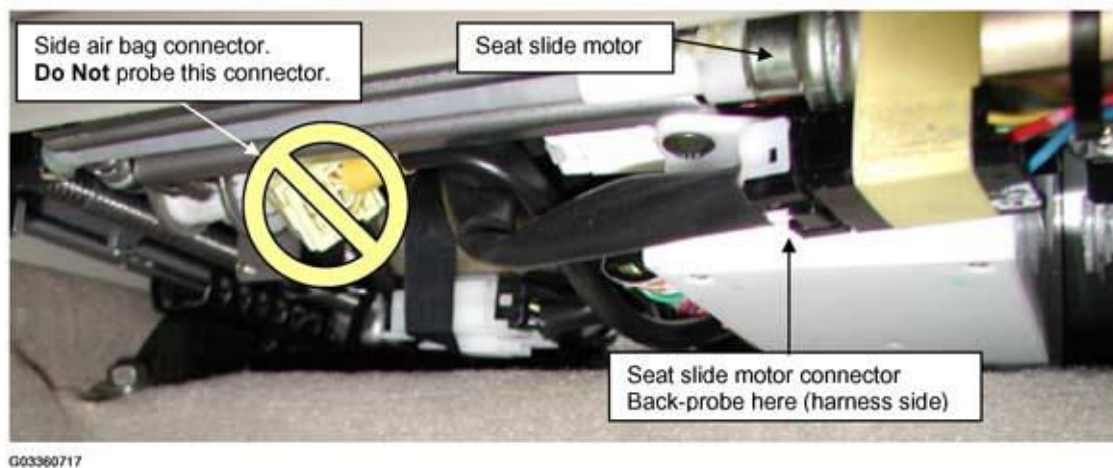

Fig. 2: Checking Voltage To Seat Slide Motor

- This voltage check can be done with the seat slide motor connected.
 - If the voltage is about 12V when the seat slide switch is pressed to the "forward" **and** "backward" positions this bulletin applies, proceed to step 3.
 - If voltage is 0V when the seat slide switch is pressed to **either** the "forward" or "backward" positions, this bulletin does not apply. Use the EL section of the appropriate Service Manual (ESM) to further diagnosis and repair the incident.
3. Record the radio station pre-sets for later reprogramming after the procedure.

RADIO STATION PRE-SETS RECORDING

Pre-sets	1	2	3	4	5	6
FM 1						
FM 2						
AM						

4. Lightly tap the seat slide motor (see [Fig. 2](#)). Sometimes this will get the motor working again temporarily so the seat can be moved to access the seat mounting bolts.
5. Move the seat bottom all the way forward and remove the two rear seat mounting bolts (M10, 14 mm head).
6. Move the seat all the way to the back position and remove the two front seat mounting bolts (M10, 14 mm head).
7. Turn the ignition key "OFF".
8. **Disconnect the battery negative cable and wait three (3) minutes.** This will allow the Supplemental Restraint System (SRS), which includes the front seat side air bags, to deactivate.
9. Tilt the entire seat assembly back so you can reach all the vehicle harness-to-seat connectors. Then, disconnect them from the seat.
10. Remove the seat assembly from vehicle and place it on a clean dry surface (use a fender cover or large floor-mat). Place it with the seat back lying flat so you can reach the underside of the seat.
11. Unhook the carpet flap from the underside of the seat bottom (see [Fig. 3](#)).

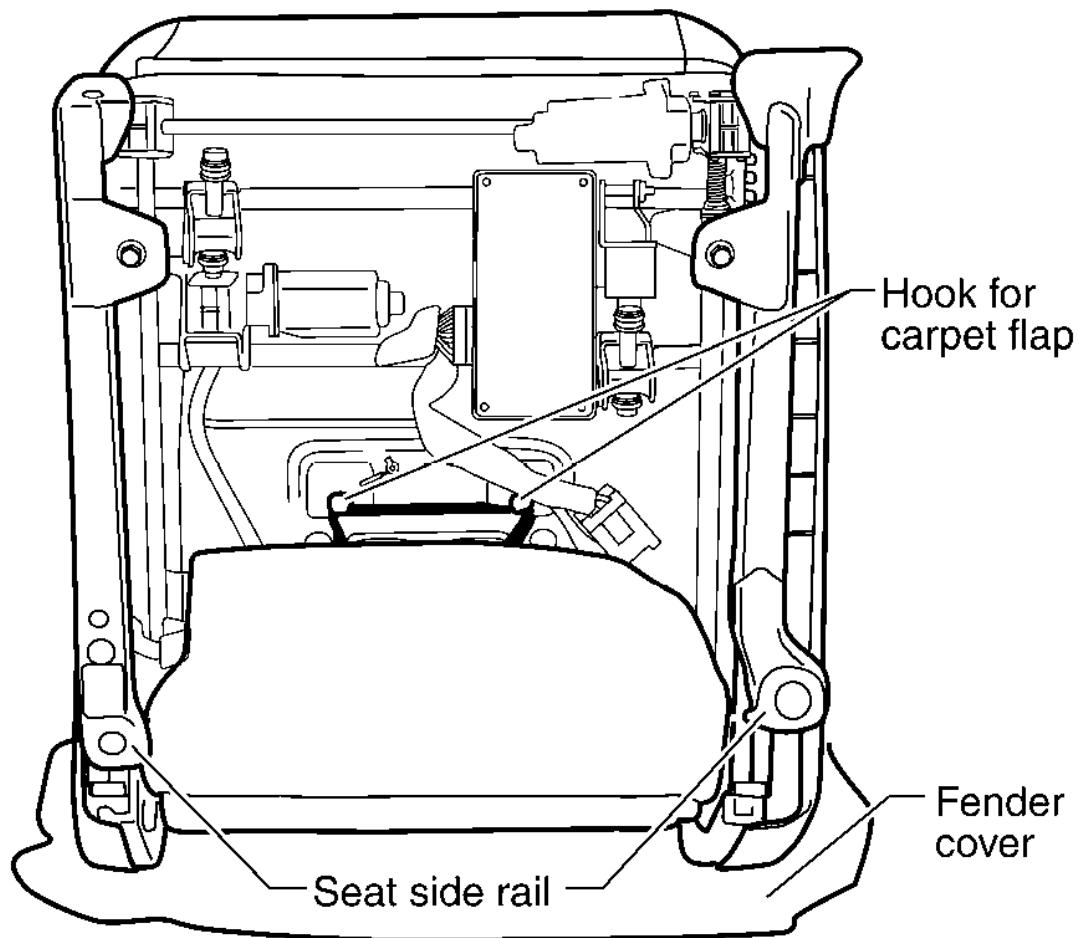

G03360718

Fig. 3: Unhooking Carpet Flap From Underside Of Seat Bottom

12. Remove the four seat bottom cushion bolts (M8, 12 mm head). These will release it from the seat frame (see [Fig. 4](#)).
 - Then, remove the two seat track mounting tab bolts (M6, 10 mm head), one on each side (see [Fig. 4](#)).
 - Removing these bolts will release the seat slide rails from the "worm gears".

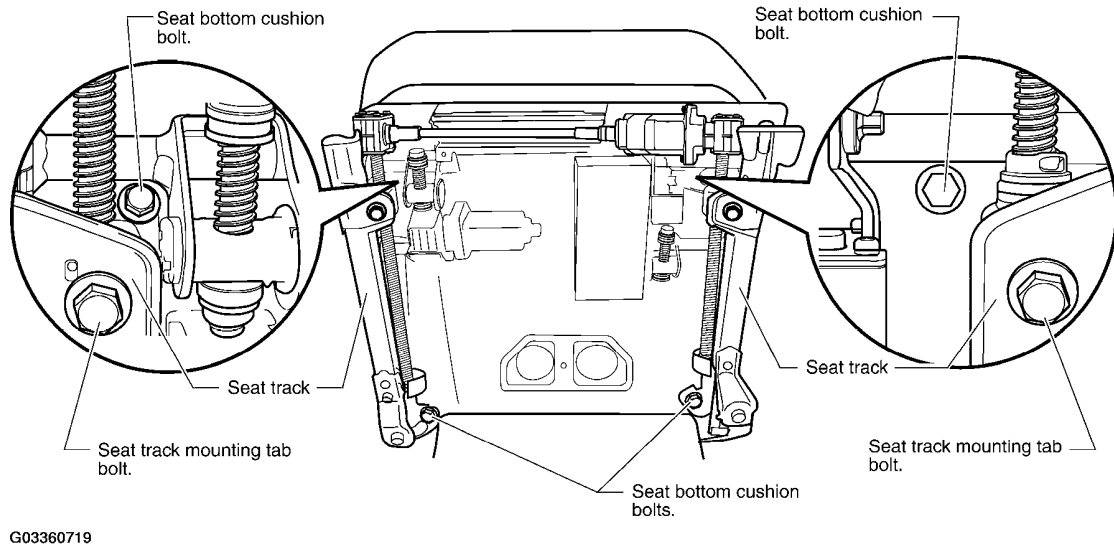
**Fig. 4: Removing Seat Bottom Cushion Bolts**

13. Remove the top screw only from the RH & LH side finishers (see figure [Fig. 5](#)).

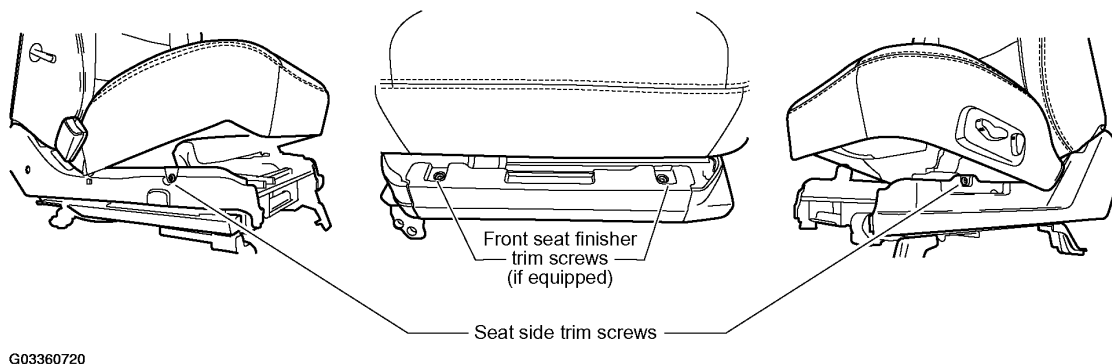
**Fig. 5: Removing Top Screw Only From RH & LH Side Finishers**

14. If equipped, remove both screws and finisher from the front edge of the seat (see figure [Fig. 5](#)).

15. Disconnect the seat sub-harness connector to slide motor (see [Fig. 6](#)).

- Remove the bolts shown below, one from each side of the seat frame (M8, 12 mm head). They're located at the sides of the front edge of the seat (see "Remove this bolt first" in [Fig. 6](#)).
- Then, remove six nuts (3 on each side) and two base plates, located at the top of the frame, to release the gear boxes (see [Fig. 6](#)).

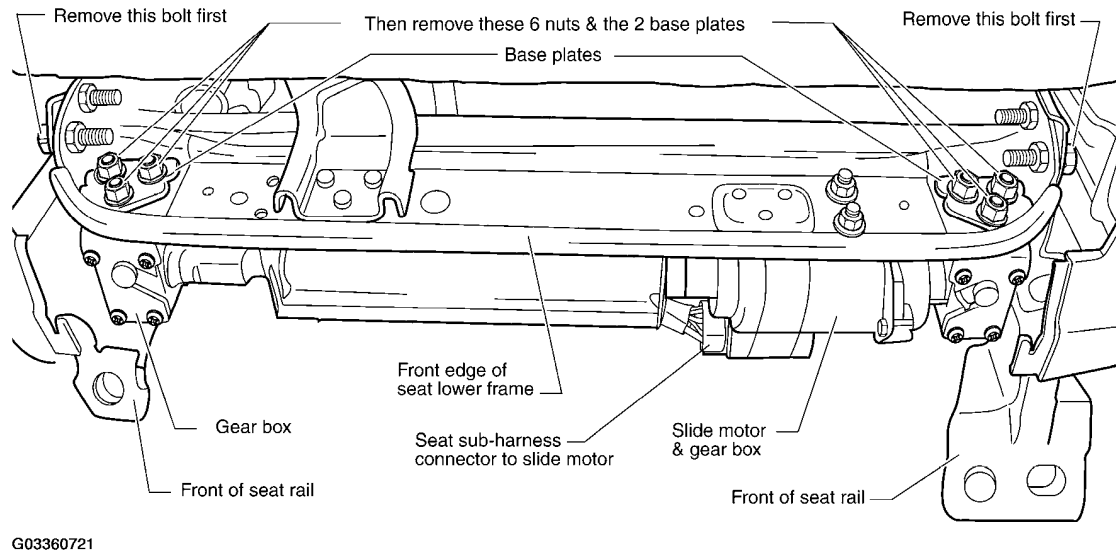

[Fig. 6: Disconnecting Seat Sub-Harness Connector To Slide Motor](#)

16. Slide both sides of the seat rail back to the rear position (towards the seat back) and remove the worm gears, drive cable, motor, and gear boxes, all as one unit, from the seat adjuster assembly (see [Fig. 7](#)).

CAUTION: Avoid bending the drive cable. Bending the cable will result in noise during seat operation.

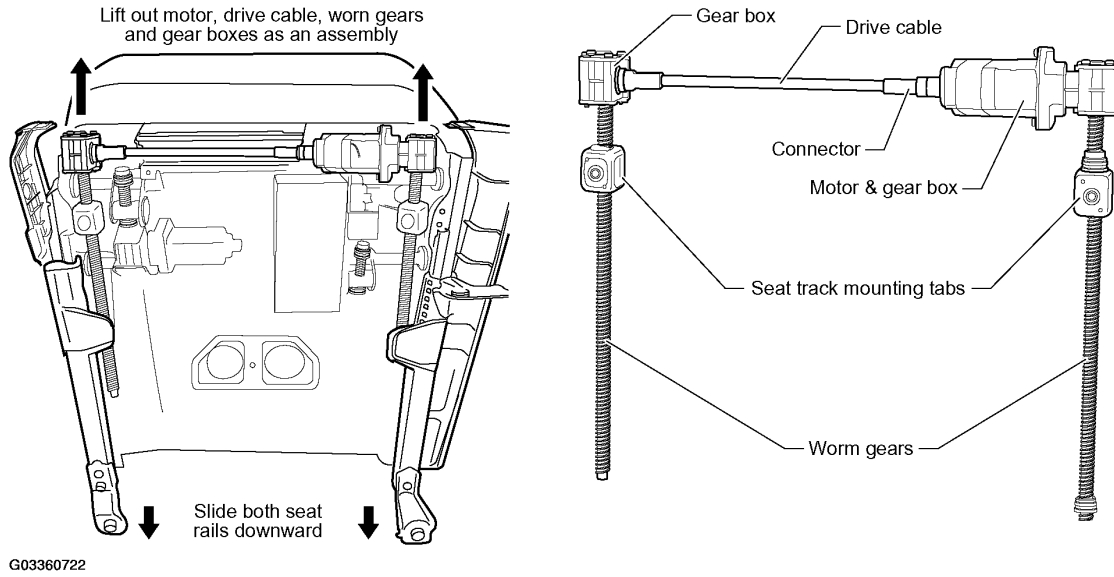
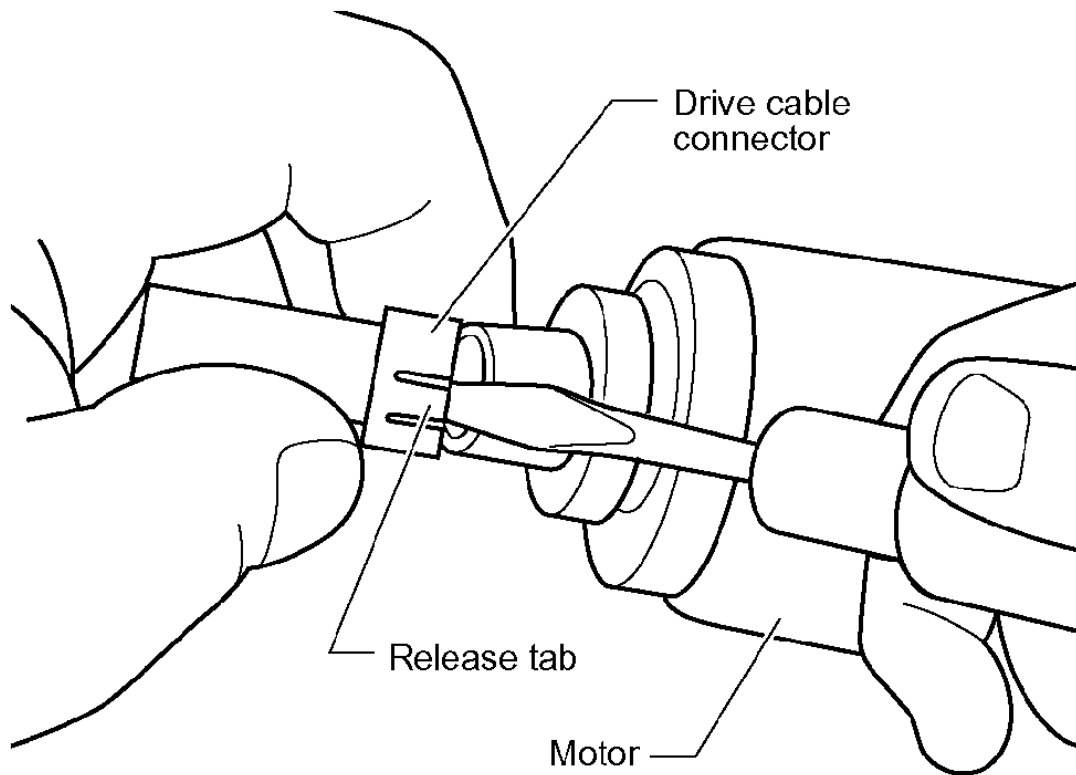

Fig. 7: Sliding Both Sides Of Seat Rail Back To Rear Position

17. Remove the drive cable from the gear boxes. To release the drive cable from the motor end, pull up on the tab using a small flat blade screwdriver or equivalent (see [Fig. 8](#)).



G03360723

Fig. 8: Removing Drive Cable From Gear Boxes

18. Make sure the new seat track mounting tab is touching the rear stopper, with the threaded shaft facing up (see [Fig. 9](#)).
 - Measure the distance between the gear box and the mounting tab (see [Fig. 9](#)).
 - Measure and adjust the other seat track mounting tab to the same distance (see [Fig. 9](#)).

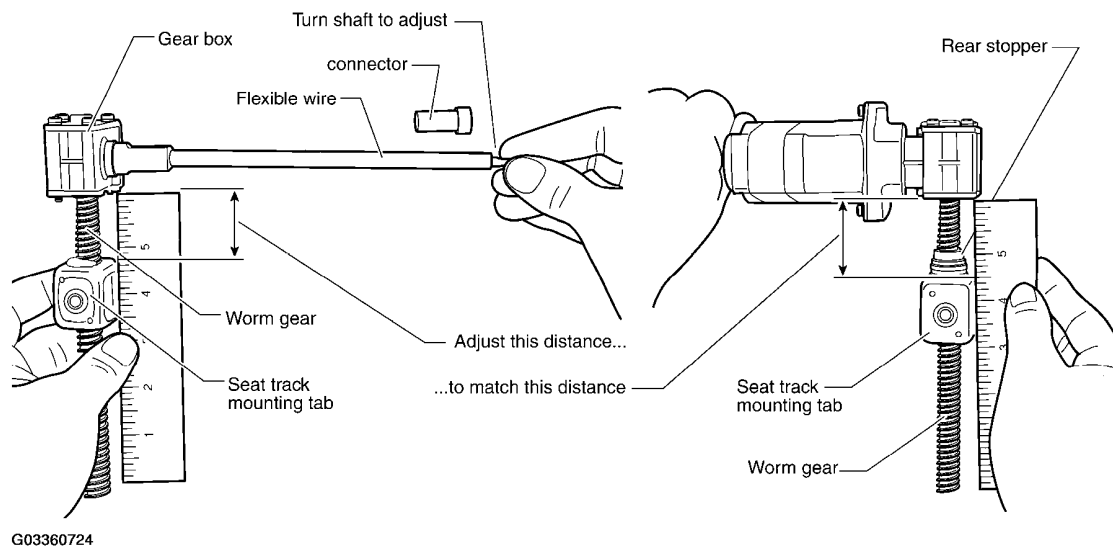

Fig. 9: Measuring Distance Between Gear Box & Mounting Tabs

19. Replace all six rubber grommets (3 to each side) from the kit (see [Fig. 10](#)).

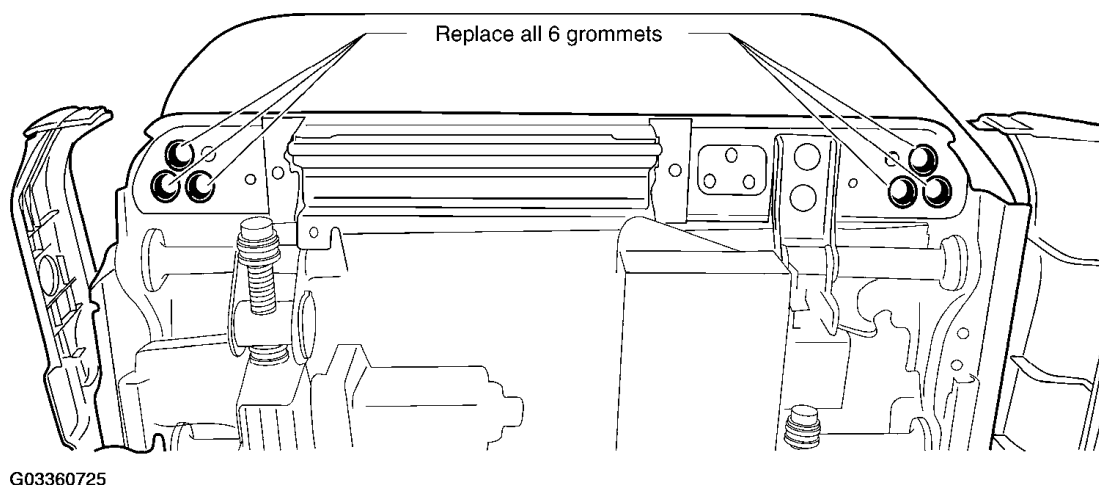

Fig. 10: Replacing All Six Rubber Grommets

NOTE: For steps 20 through 23 (below), refer to [Fig. 6](#) and [Fig. 7](#) , if needed.

20. Put the worm gears, gear boxes, and drive cable assembly (all as one unit) back into the seat frame.

CAUTION: Avoid bending the drive cable. Bending the drive cable will create a noise when the seat is operated.

21. Move both seat tracks back into position on top of the seat track mounting tabs. Install and hand tighten the bolts into both seat track mounting tabs (M6, 10 mm head).
22. Tighten the six nuts (three on each side) with the base plates, located at the top of the frame, to secure the gear boxes (refer to [Fig. 6](#) if needed). Nut torque: 64-85 in-lb (7.17-9.69 N.m).
23. Re-install and tighten two bolts (M8, 12 mm head) located to the sides of the front edge of the seat frame (see "Remove this bolt first" in [Fig. 6](#)). Bolt torque: 13-17 ft-lb (17.5-23.7 N.m).
24. Check the gear box to mounting tab distance again. Make sure the distance has not changed (see [Fig. 11](#)).
 - If N/G, adjust.

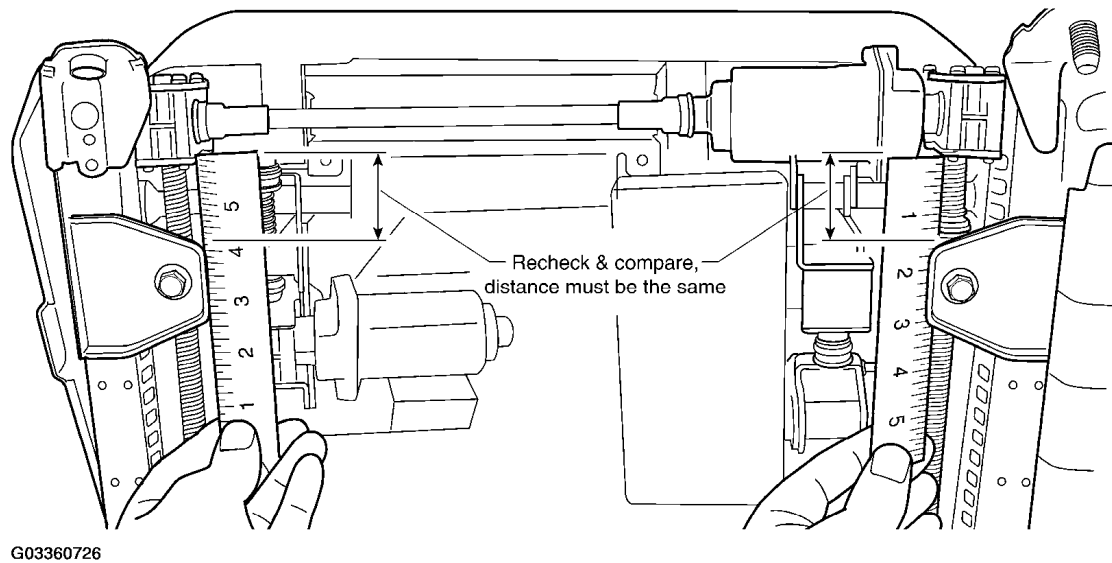

[Fig. 11: Checking Gear Box To Mounting Tab Distance](#)

25. Tighten bolts (M6, 10 mm head) into both seat track mounting tabs (see [Fig. 4](#)). Bolt torque: 65-84 in-lb (7.3-9.4 N.m).
26. Re-install screws to attach the side finishers and the front finisher (refer to [Fig. 5](#) if needed).
27. Re-install four bolts (M8, 12 mm head) to tighten the seat bottom cushion to the seat frame (refer to [Fig. 4](#) if needed). Bolt torque: 13-17 ft-lb (17.5-23.7 N.m).
28. Re-connect the slide motor electrical connector, making sure it snaps in place.
29. Re-hook the strap to attach the carpet flap onto the bottom of the seat (refer to [Fig. 3](#) if needed).
30. Place the seat assembly back into the vehicle and re-connect all electrical connectors. Make sure they all snap together securely.
31. Re-connect the battery negative cable.
32. Re-install four seat mounting bolts. Bolt torque: 27-36 ft-lb (37-49 N.m)
33. Operate all seat switches to make sure everything works as it should.
34. If the vehicle is equipped with "ADP": For the ADP entry/exit feature to return to normal operation, procedure A or B must be performed.

Procedure A:

1. Insert key into the ignition key cylinder. (Ignition switch is "OFF".)
2. Open - close - open the driver side door (dome lamp; "ON" - "OFF" - "ON").
3. End

Procedure B:

1. Drive the vehicle at more than 25 km/h (16 MPH).
 2. End
35. Re-program the radio presets.
 36. Re-set the clock.

© 2006 Mitchell Repair Information Co., LLC.