

REMOVAL & INSTALLATION

CAUTION: This application is an interference engine. Do not rotate camshaft or crankshaft when timing belt is removed, or engine damage may occur.

TIMING BELT

Removal

1. Disconnect negative battery cable. Disconnect intake air temperature sensor connector from intake air duct. Disconnect the air intake tube from the throttle body. Disconnect the breather tube from the valve cover. Remove the air filter housing.
2. Raise and support the vehicle. Remove right front wheel. Remove right front splash shield from wheelwell. Remove serpentine accessory drive belt.
3. Remove crankshaft pulley bolts. It is NOT necessary to remove crankshaft sprocket center bolt. Remove crankshaft pulley. Lower vehicle.
4. Support engine assembly from above with Support Fixture (J-28467-B). See **Fig. 1** . Remove engine mount bracket from timing belt end of engine. See **Fig. 2** .
5. Remove front timing belt cover. Using crankshaft center bolt, rotate crankshaft one full turn clockwise (as viewed from timing belt end of engine).
6. Align mark on crankshaft sprocket with notch at bottom of rear timing belt cover. See **Fig. 3** . Align camshaft sprocket timing marks with notches on valve cover. See **Fig. 4** .

CAUTION: Engine damage could result if camshaft sprockets are not properly aligned with notches on valve cover.

7. Loosen the automatic tensioner bolt. Use an Allen wrench to rotate tensioner and relieve tension on timing belt. See **Fig. 5** . Remove timing belt.

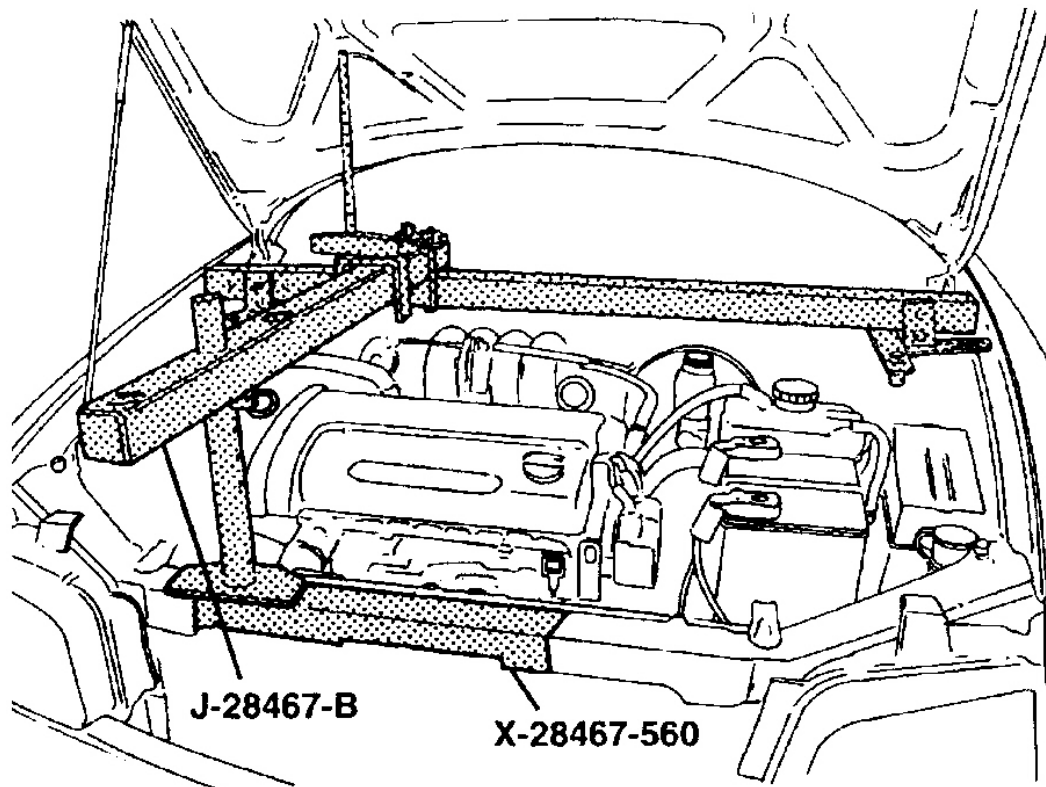

G00049728

Fig. 1: Supporting Engine Assembly
Courtesy of DAEWOO MOTOR AMERICA, INC.

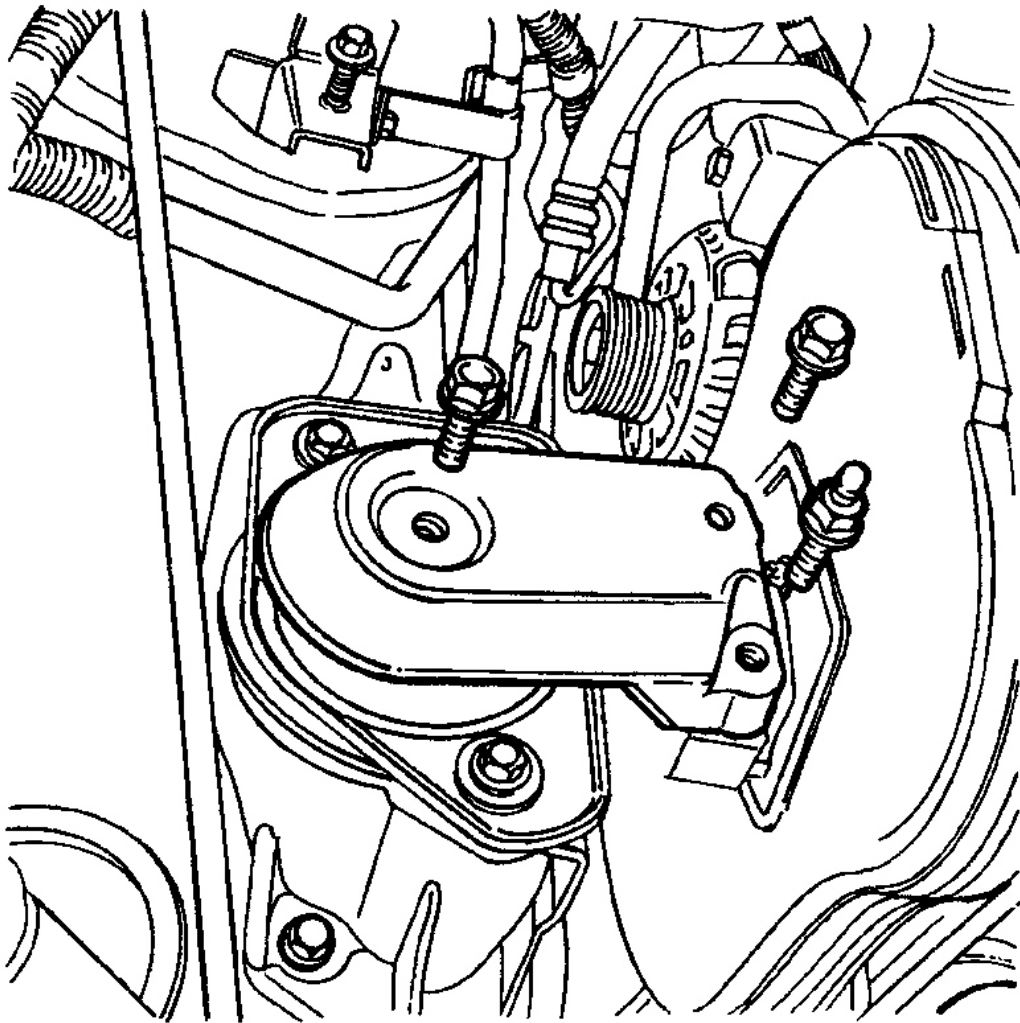

G00049709

Fig. 2: Removing Engine Mount Bracket
Courtesy of DAEWOO MOTOR AMERICA, INC.

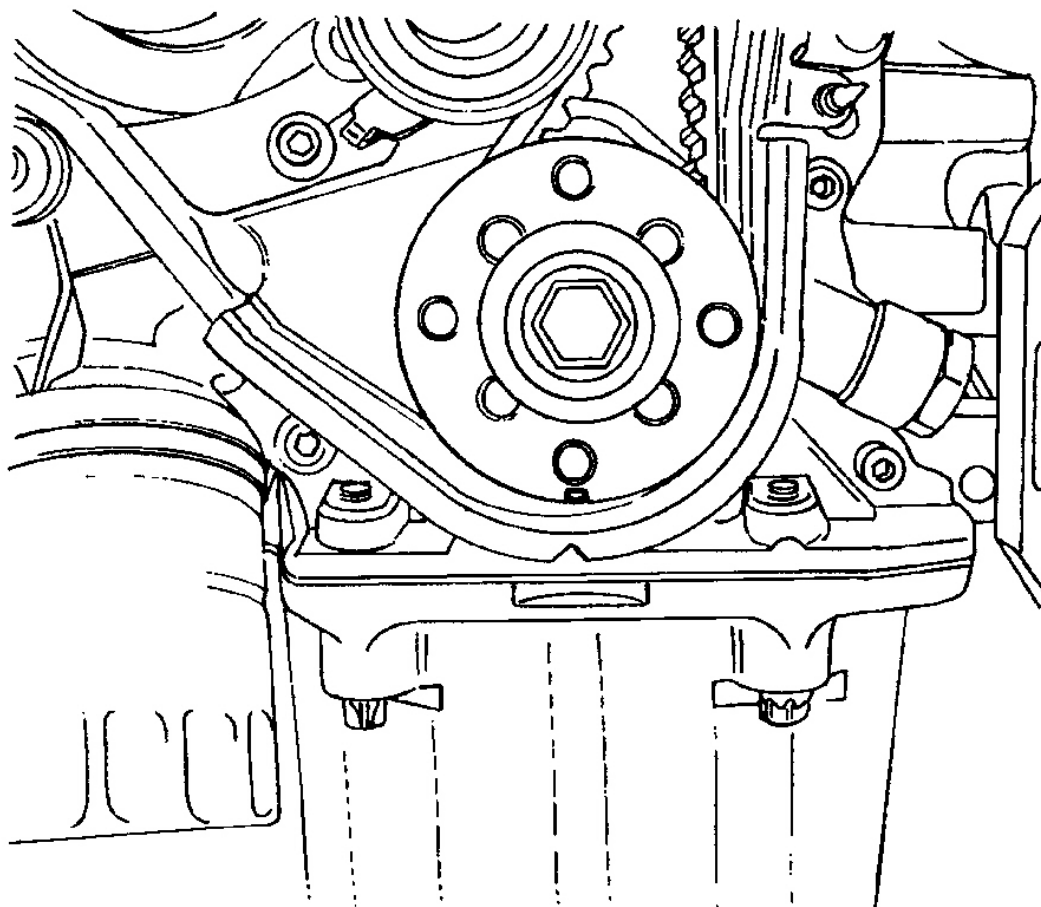

G00049720

Fig. 3: Aligning Crankshaft Sprocket Timing Marks
Courtesy of DAEWOO MOTOR AMERICA, INC.

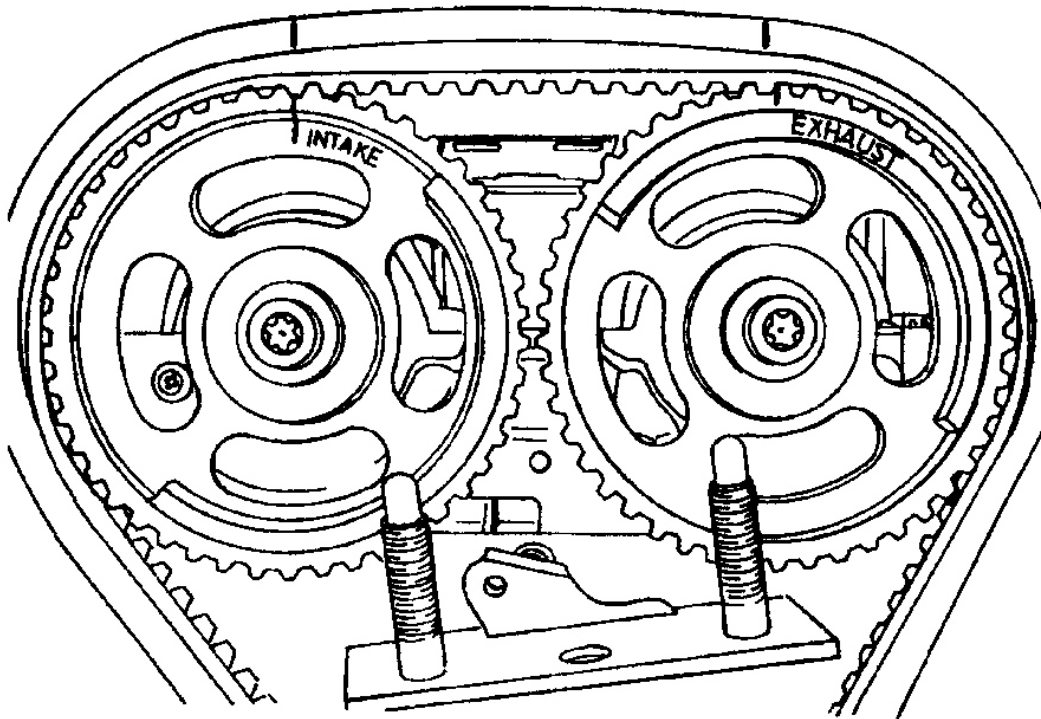

G00049719

Fig. 4: Aligning Camshaft Sprocket Timing Marks
Courtesy of DAEWOO MOTOR AMERICA, INC.

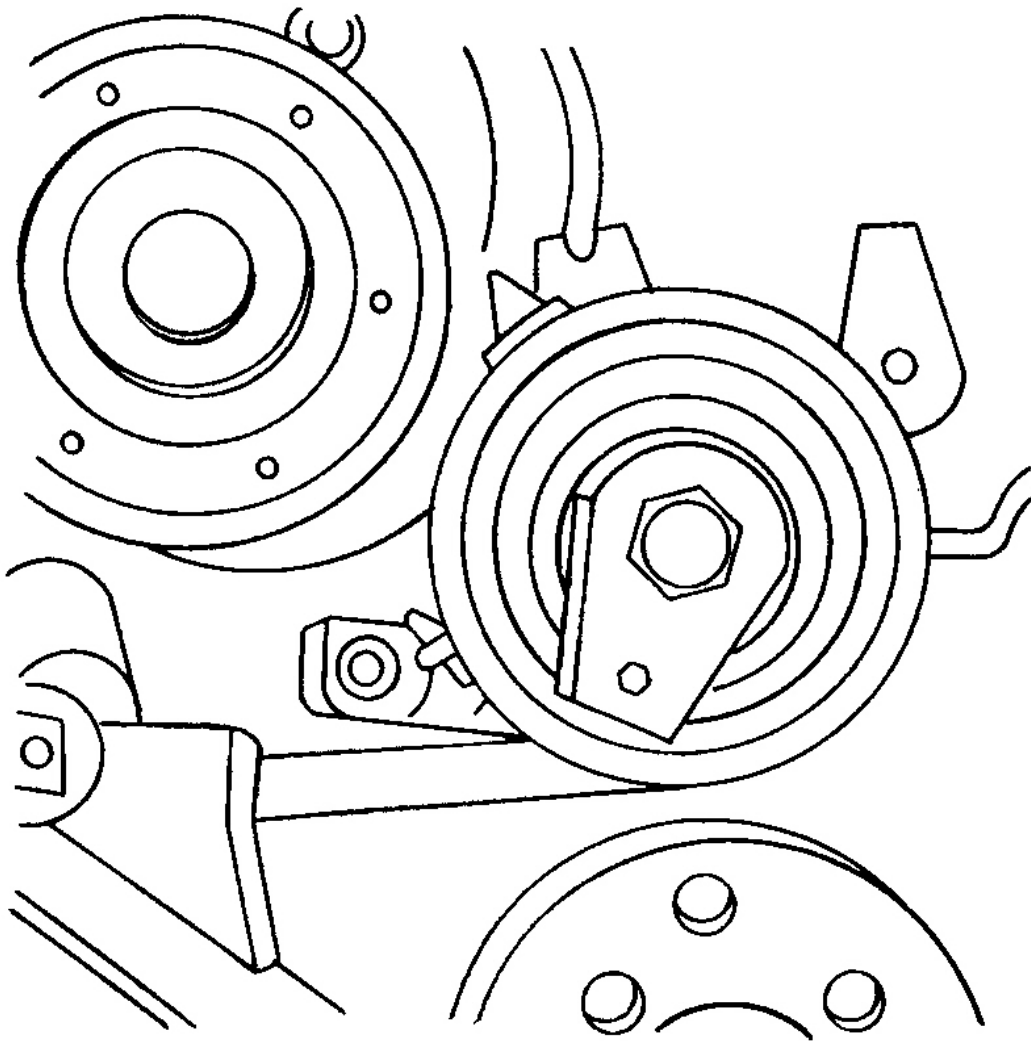

G00049711

Fig. 5: Locating Timing Belt Tensioner
Courtesy of DAEWOO MOTOR AMERICA, INC.

Installation

1. Ensure crankshaft and camshaft timing marks are still aligned. Install the timing belt. See **Fig. 6**. Turn the timing belt tensioner clockwise to tension the timing belt. Turn tensioner until the pointer aligns with the notch on the rear timing belt cover. Tighten automatic tensioner bolt. See **TORQUE SPECIFICATIONS**.
2. Using crankshaft center bolt, turn crankshaft clockwise (as viewed from timing belt end of engine) 2 full revolutions. Ensure timing belt tensioner pointer is still aligned with notch.

3. If timing belt tensioner is correctly aligned, install timing belt cover. Install the engine mount bracket on the timing belt end of engine. Install crankshaft pulley. Install serpentine accessory drive belt. Install right front splash shield. Install right front wheel.
4. Install air filter housing. Connect air intake temperature sensor connector. Connect negative battery cable.

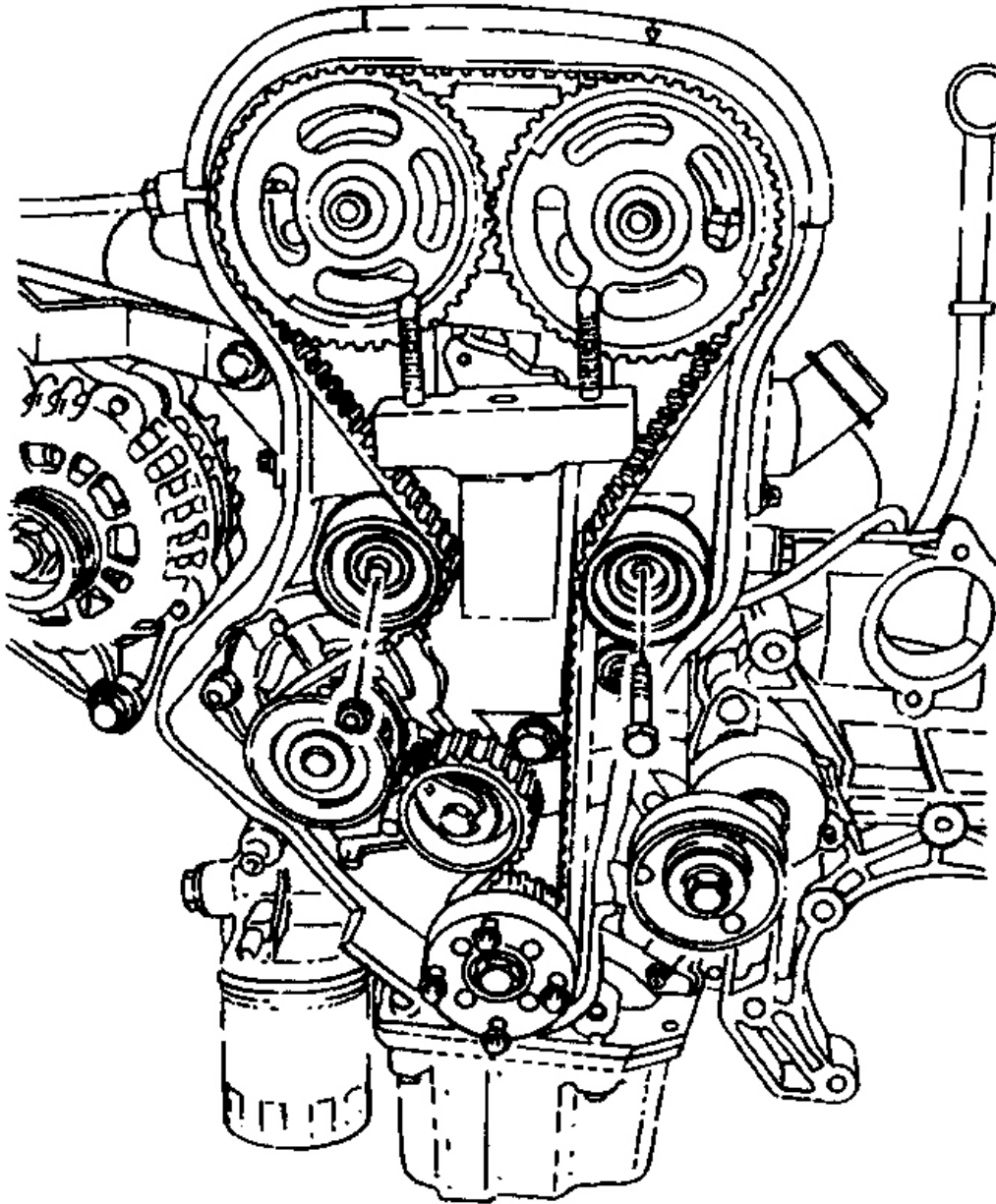

G00049712

Fig. 6: Identifying Timing Belt Routing
 Courtesy of DAEWOO MOTOR AMERICA, INC.

TORQUE SPECIFICATIONS

TORQUE SPECIFICATIONS

Application	Ft. Lbs. (N.m)
Camshaft Sprocket Bolt	
Step 1	37 (50)
Step 2	Plus 60 Degrees
Step 3	Plus 15 Degrees
Crankshaft Pulley Bolt	15 (20)
Crankshaft Sprocket Center Bolt	
Step 1	96 (130)
Step 2	Plus 40-50 Degrees
Engine Mount Bracket Bolt	44 (60)
Timing Belt Idler Pulley Bolt/Nut	18 (25)
Timing Belt Tensioner Bolt	18 (25)
Water Pump Bolt	15 (20)
Wheel Lug Nuts	88 (120)
	INCH Lbs. (N.m)
Timing Belt Cover Bolt	53 (6)