

VALVE BODY RECONDITION

NOTE: Prior to removing any transaxle subassemblies, plug all openings and thoroughly clean exterior of the unit, preferably by steam. Cleanliness through entire disassembly and assembly cannot be overemphasized. When disassembling, each part should be washed in a suitable solvent, then dried by compressed air. Do not wipe parts with shop towels. All mating surfaces in the transaxles are accurately machined; therefore, careful handling of all parts must be exercised to avoid nicks or burrs. Remove all old R.T.V. sealant before applying new R.T.V. sealant. Use only R.T.V. sealant when installing oil pan.

1. Remove or install neutral starting and back-up lamp switch.

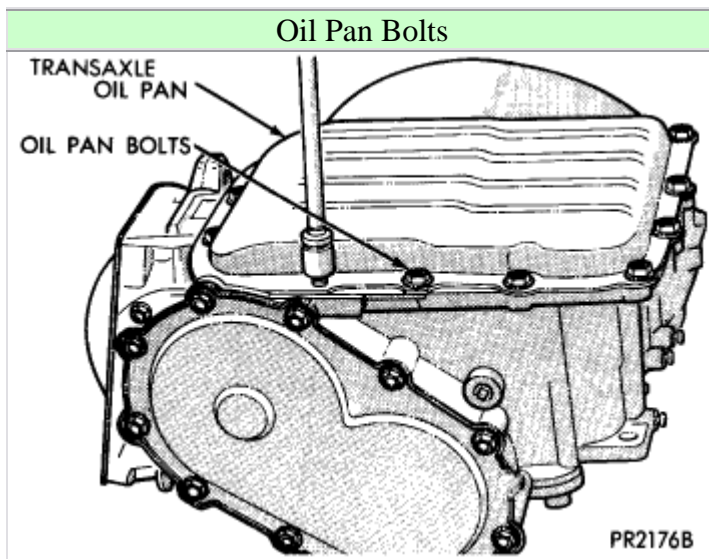

Zoom

Sized for Print

Oil Pan

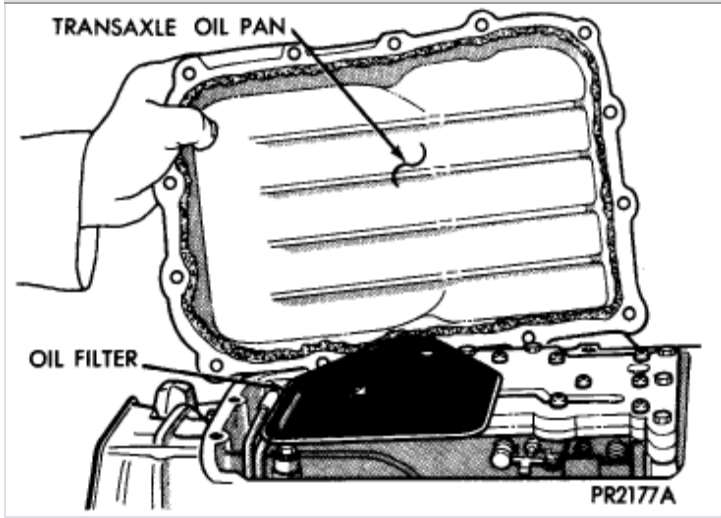

Zoom

Sized for Print

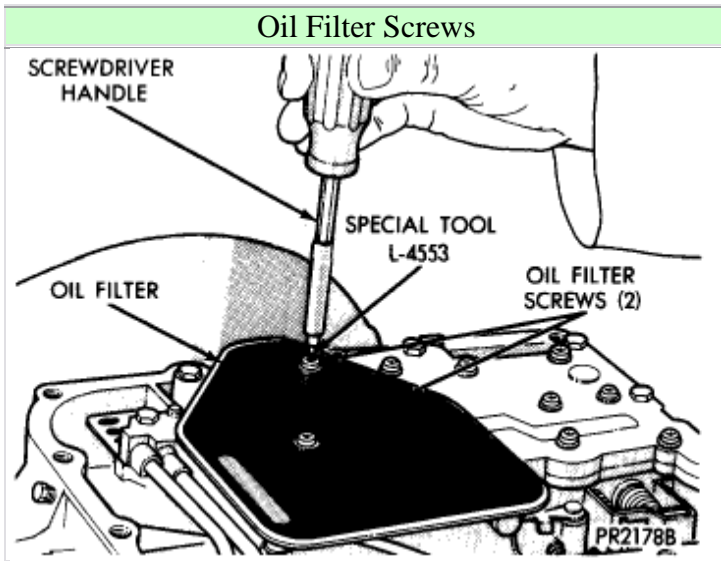

Zoom

Sized for Print

Oil Filter

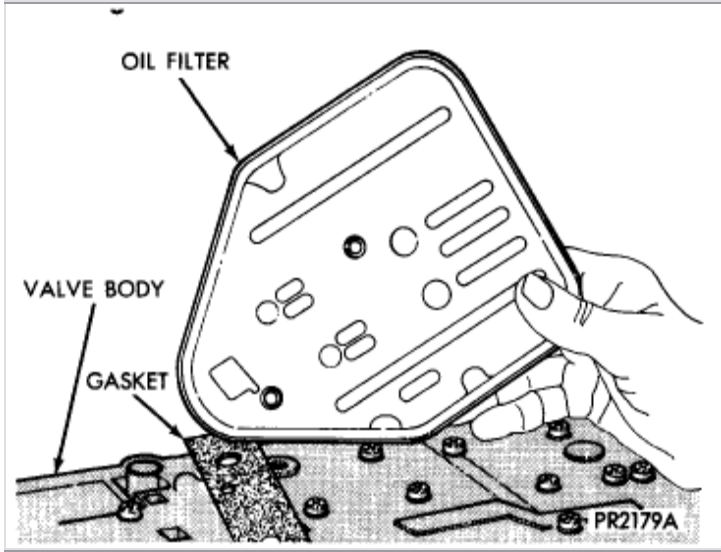

Zoom

Sized for Print

Parking Rod E-Clip

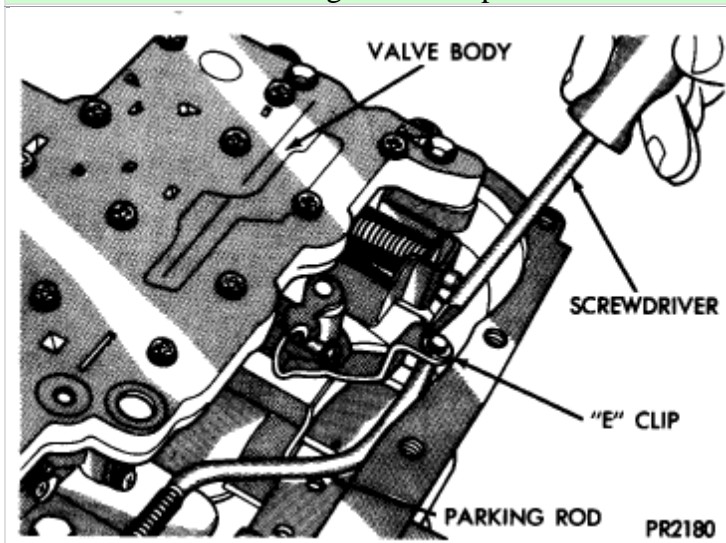

Zoom

Sized for Print

Parking Rod

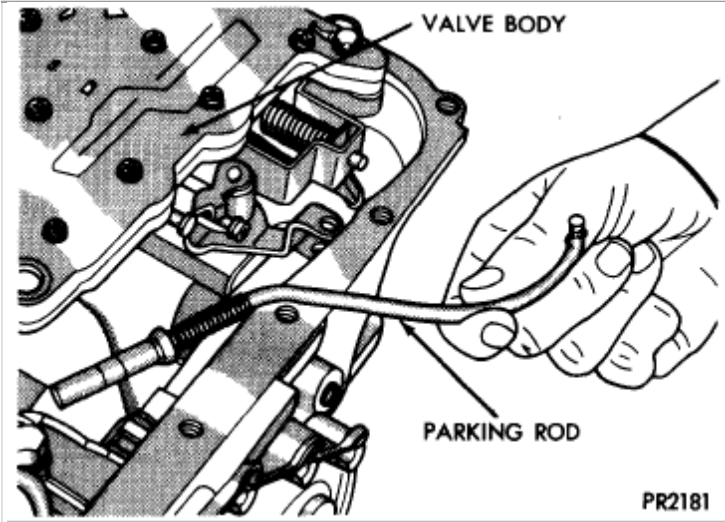

Zoom

Sized for Print

Valve Body Attaching Bolts

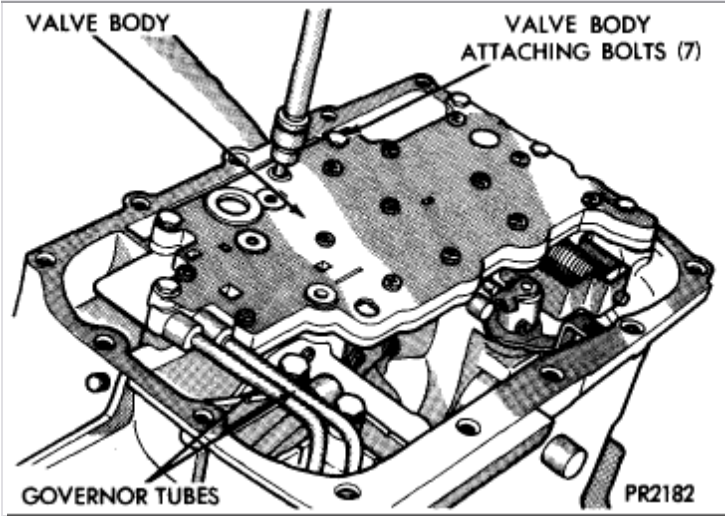

Zoom

Sized for Print

Valve Body And Governor Tubes

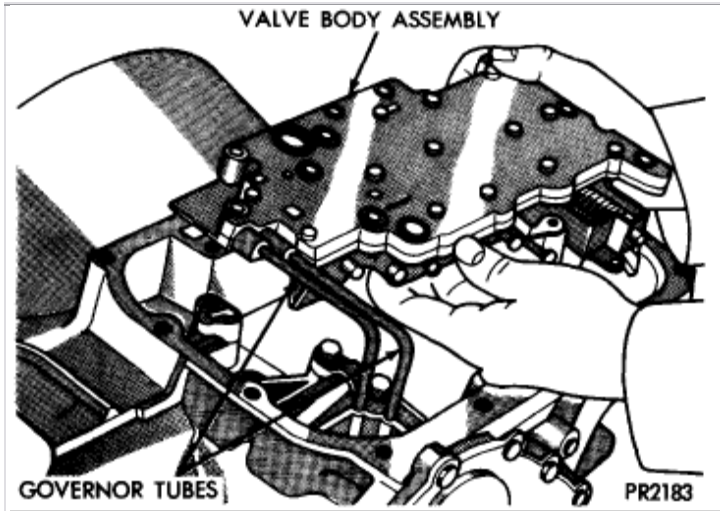

Zoom Sized for Print

CAUTION: Do not clamp any portion of valve body or transfer plate in a vise. Any slight distortion of the aluminum body or transfer plate will result in sticking valves, excessive leakage, or both. When removing or installing valves or plugs, slide them in or out carefully. Do not use force.

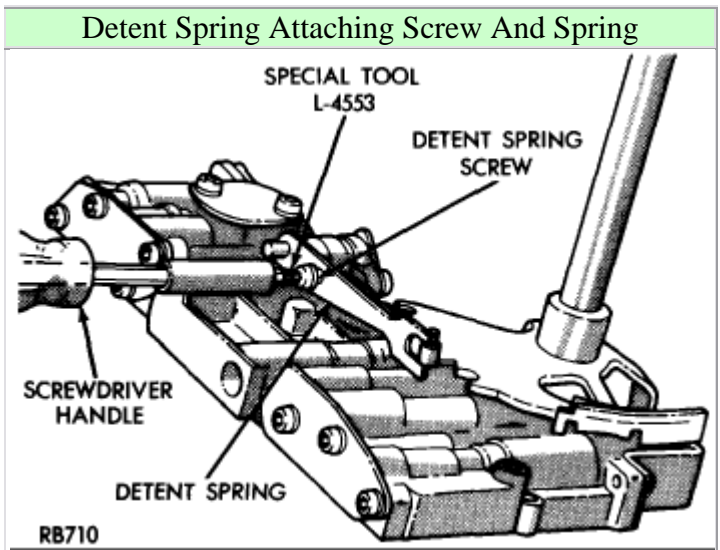

Zoom Sized for Print

WARNING: Tag all springs as they are removed for reassembly identification .

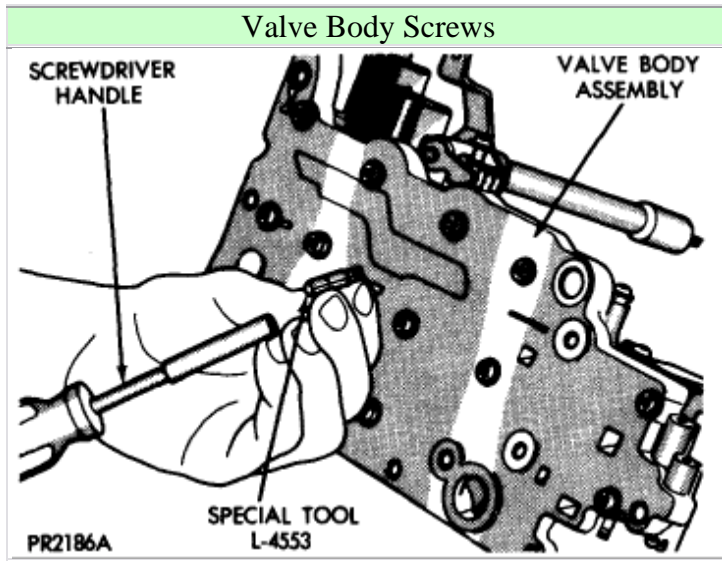

Zoom

Sized for Print

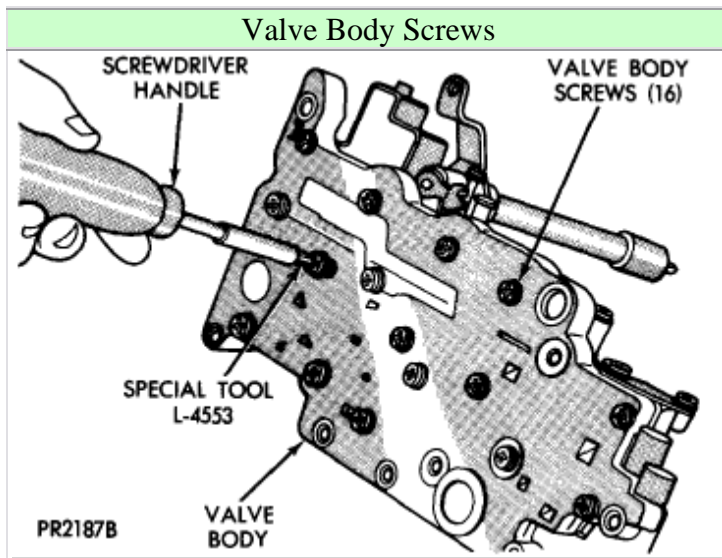

Zoom

Sized for Print

Transfer Plate And Separator Plate

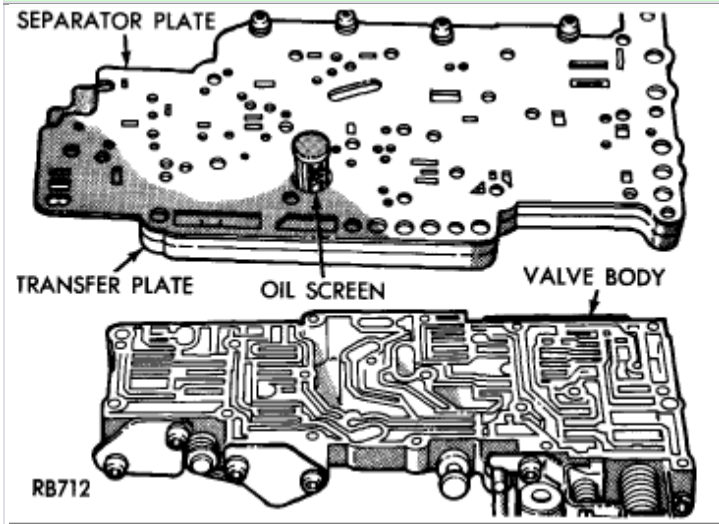

Zoom

Sized for Print

Steel Ball Locations

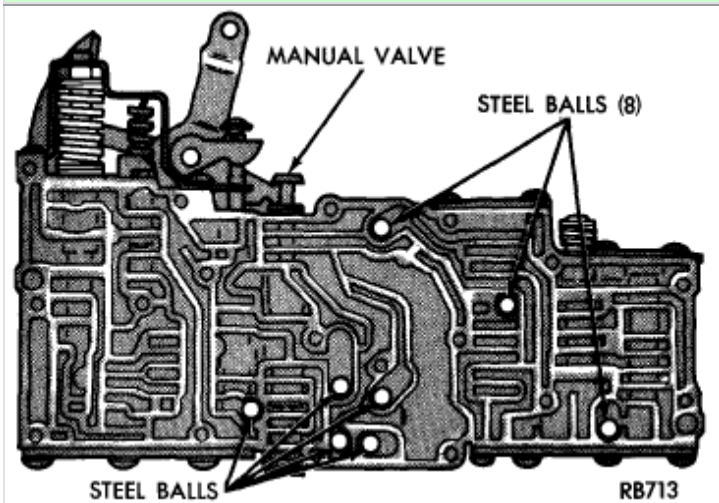

Zoom

Sized for Print

Throttle Shaft E-Clip

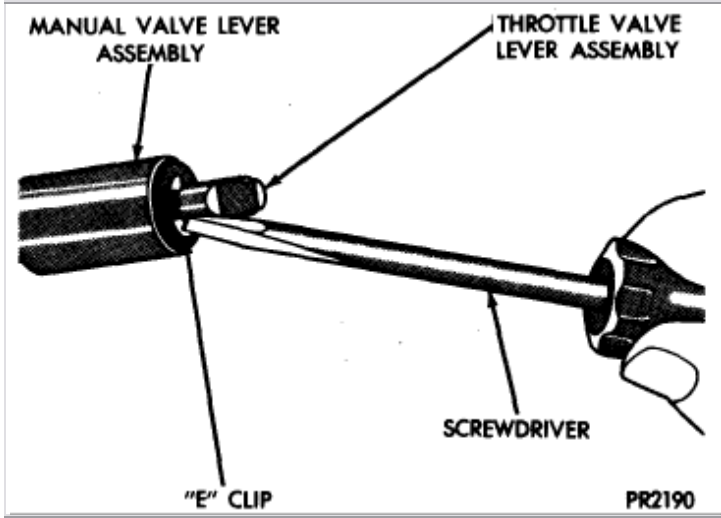

Zoom

Sized for Print

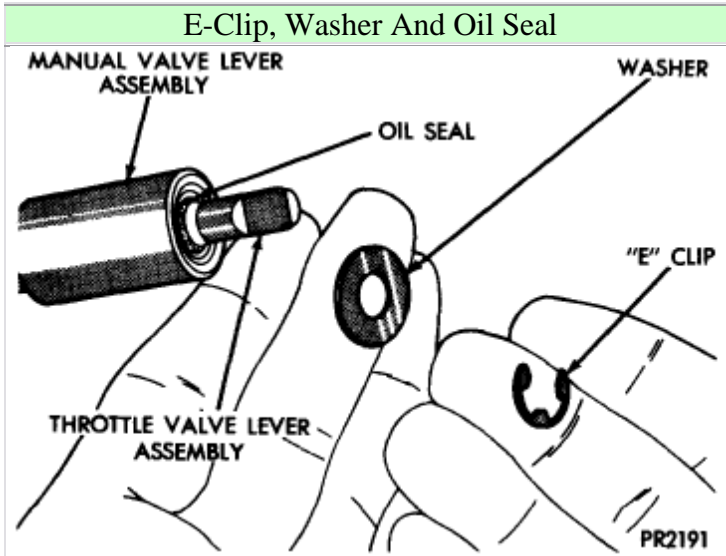

Zoom

Sized for Print

Manual Valve Lever And Assembly

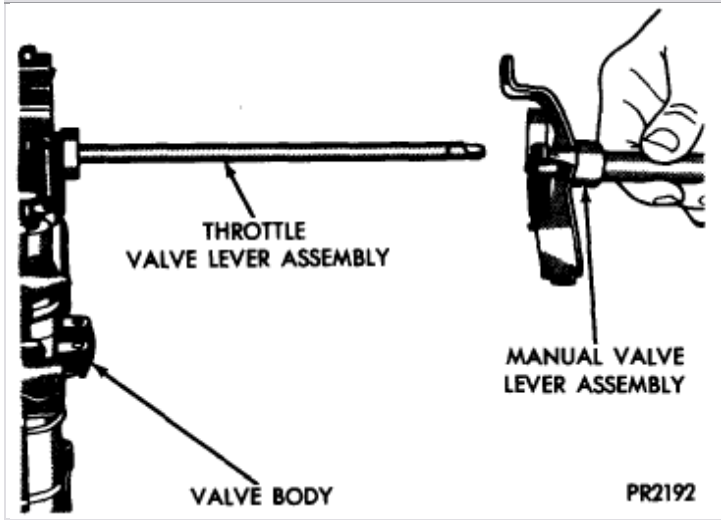

Zoom

Sized for Print

Throttle Valve Lever And Assembly

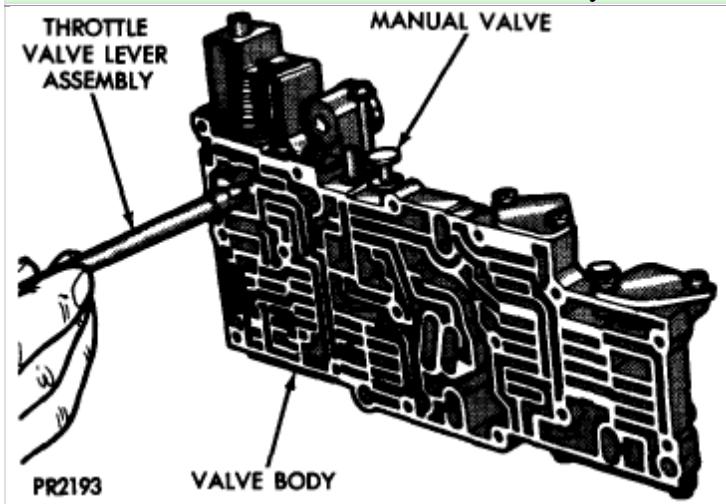

Zoom

Sized for Print

Manual Valve

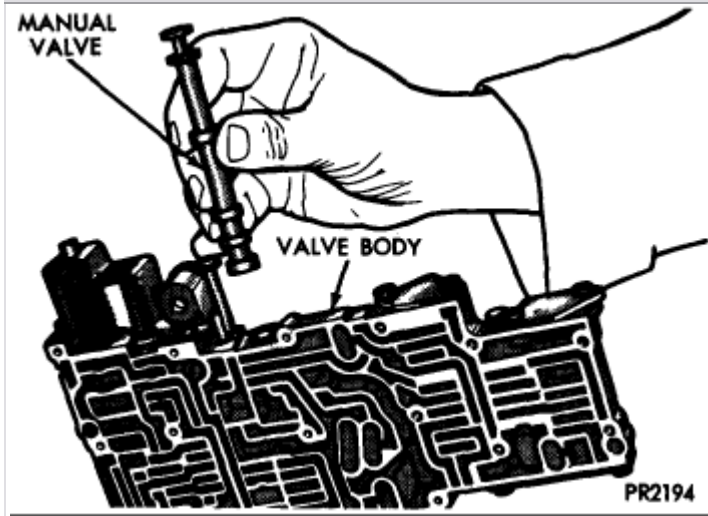

Zoom

Sized for Print

Pressure Regulator And Adjusting Screw Bracket

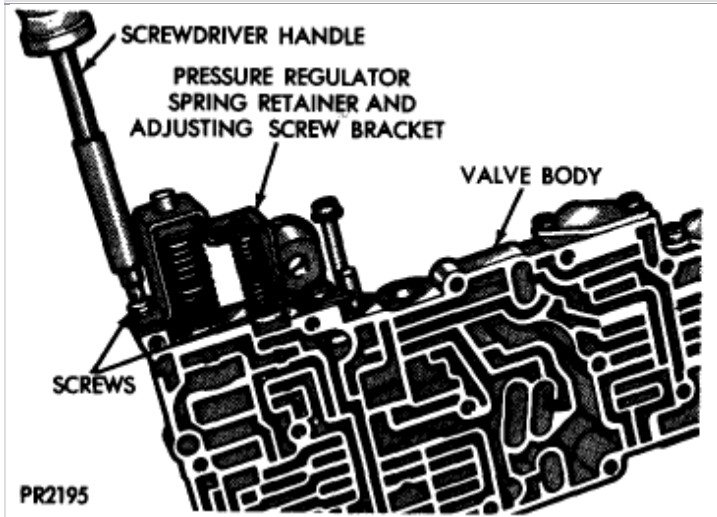

Zoom

Sized for Print

Pressure Regulators And Manual Controls

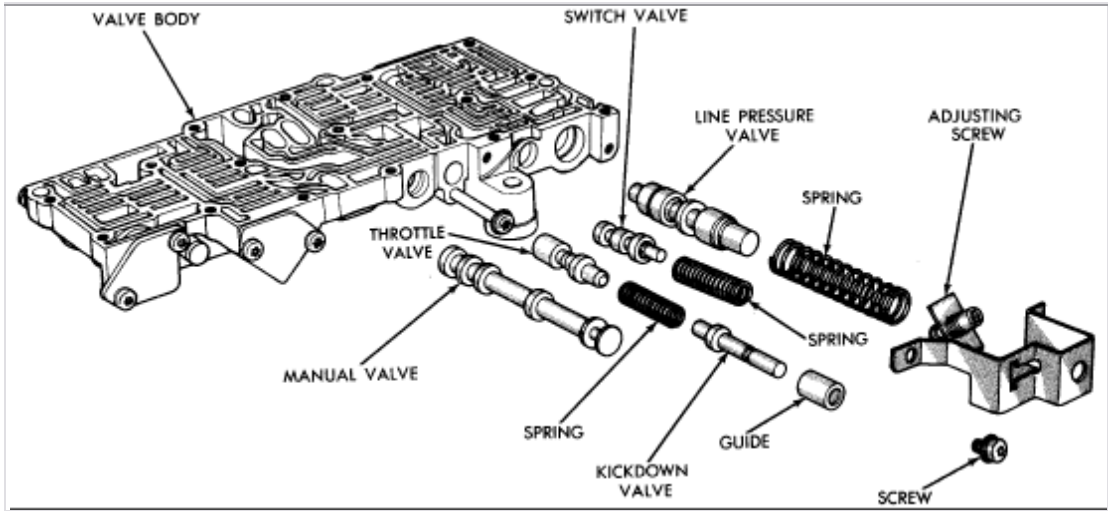

Zoom

Sized for Print

Governor Plugs

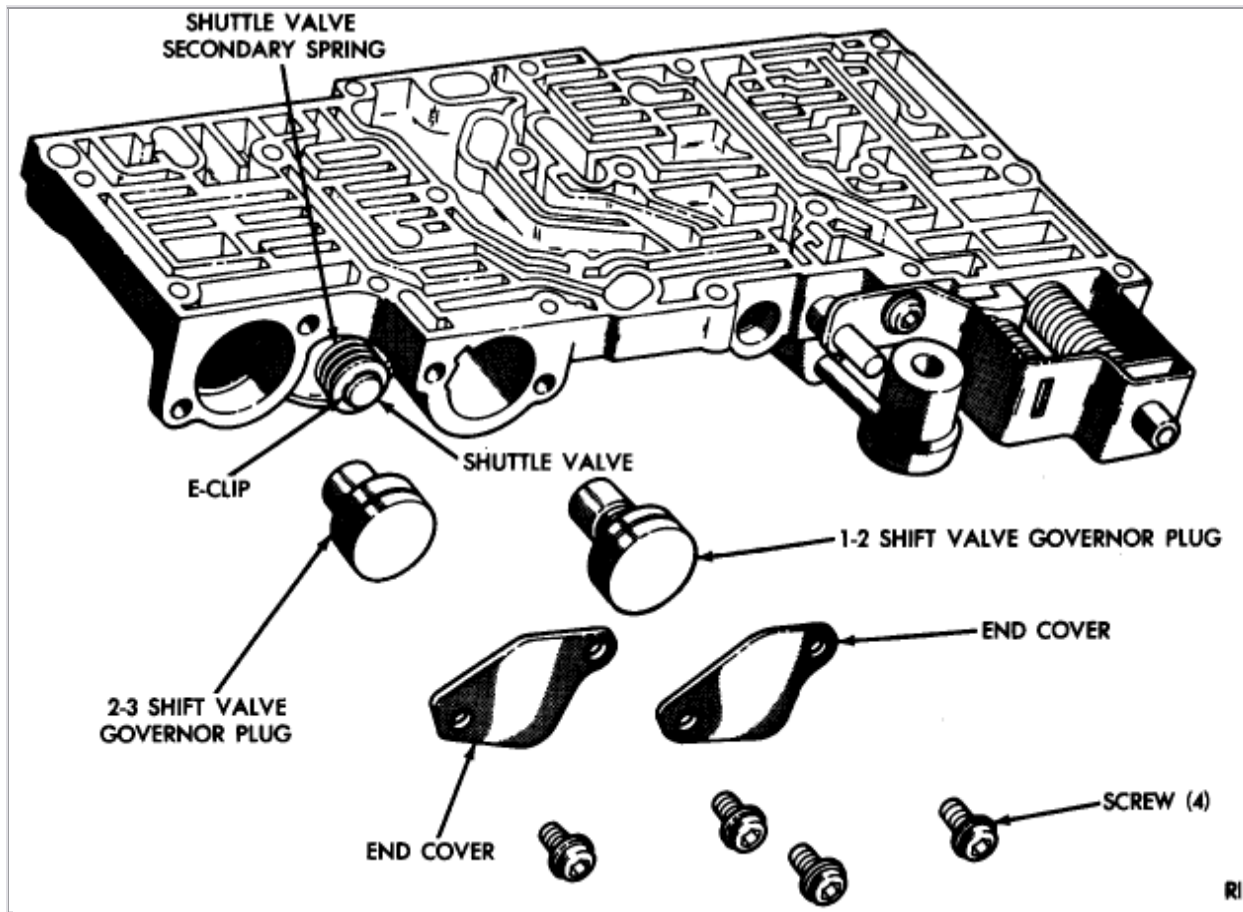

Zoom

Sized for Print

Pressure Regulator Valve Plugs

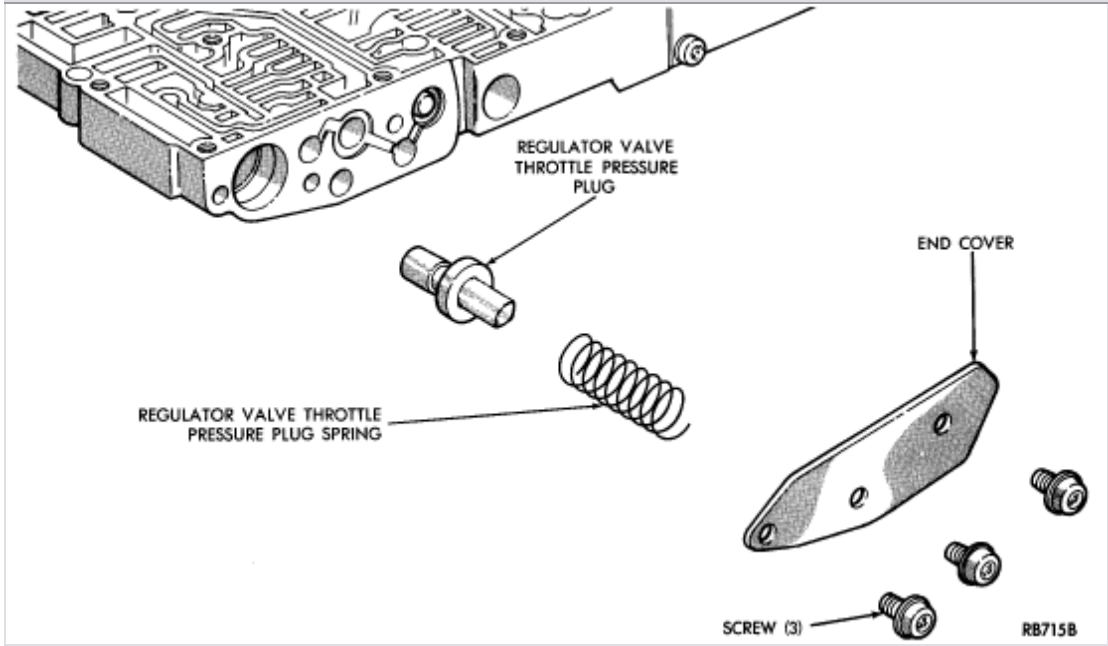

Zoom

Sized for Print

Shift And Shuttle Valves

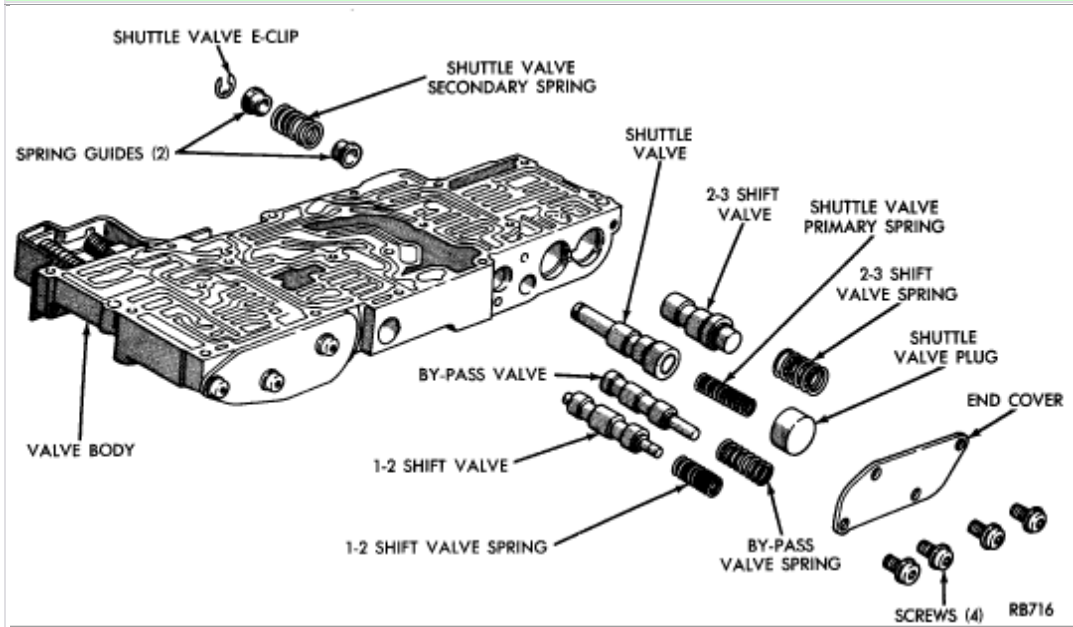

Zoom

Sized for Print

CLEANING AND INSPECTION

1. Allow all parts to soak a few minutes in a suitable clean solvent. Wash thoroughly and blow dry with compressed air. Make sure all passages are clean and free from obstructions.
2. Inspect manual and throttle valve operating levers and shafts for being bent, worn or loose. If a lever is loose on its shaft, it should be replaced. Do not attempt to straighten bent levers.
3. Inspect all mating surfaces for burrs, nicks and scratches. Minor blemishes may be removed with crocus cloth, using only a very light pressure. Using a straightedge, inspect all mating surfaces for warpage or distortion. Slight distortion may be corrected, using a surface plate. Make sure all metering holes in steel plate are open. Using a pen light, inspect bores in valve body for scores scratches, pits and irregularities.
4. Inspect all valve springs for distortion and collapsed coils. Inspect all valves and plugs for burrs, nicks, and scores. Small nicks and scores may be removed with crocus cloth, providing extreme care is taken not to round off sharp edges. The sharpness of these edges is vitally important because it prevents foreign matter from lodging between valve and valve body, thus reducing possibility of sticking. Inspect all valves and plugs for freedom of operation in valve body bores.
5. When bores, valves, and plugs are clean and dry, the valves and plugs should fall freely in the bores. The valve body bores do not change dimensionally with use. Therefore, a valve body that was functioning properly when vehicle was new, will operate correctly if it is properly and thoroughly cleaned. There is no need to replace valve body unless it is damaged in handling.
6. Installation is the reverse of removal. Tighten all valve body screws to **5 Nm (40 in.lbs.)** . Fill transaxle to the proper level with [ATF](#).