

FUSES & CIRCUIT BREAKERS

1989-95 FUSES & CIRCUIT BREAKERS Ford Motor Co.

FUSES & CIRCUIT BREAKERS

INTERIOR FUSE PANEL IDENTIFICATION (1983-88 MODELS)

On all models, the fuse panel is located under the instrument panel, left of the steering column.

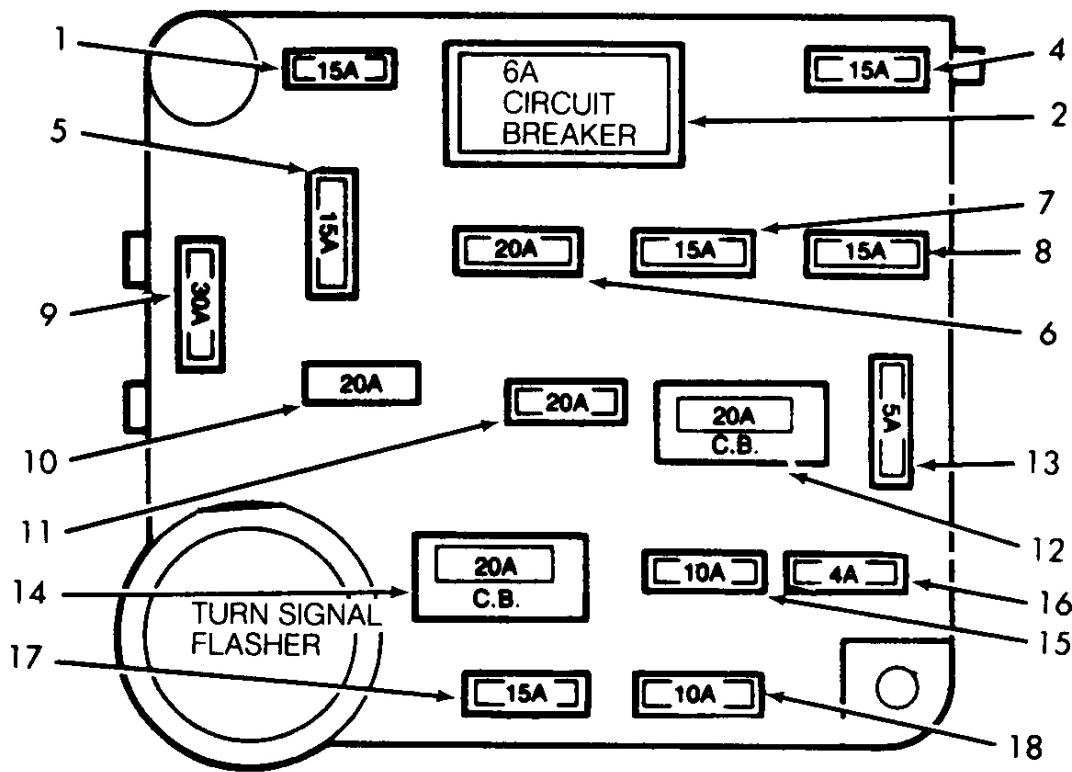

93H44641

**Fig. 1: Interior Fuse Panel Identification (1983-88 Models)**  
 Courtesy of FORD MOTOR CO.

**Fuse & Circuit Breaker Identification**

1 - 15 Amp

Brake & Hazard Warning Lights, Speed Control Module,

Cornering Light Relay



## 1994 Ford Thunderbird LX

FUSES & CIRCUIT BREAKERS '1989-95 FUSES & CIRCUIT BREAKERS Ford Motor Co.

### 2 - 6-Amp Circuit Breaker

Windshield Wiper & Washer Pump, Interval Wiper

### 3 - Not Used

### 4 - 15 Amp

Taillights, License & Parking Lights, Side Marker & Coach

Lights, Cluster Illumination Lights, Radio & Clock

Illuminator, A/C-Heater Illumination

### 5 - 15 Amp

Turn Signal & Back-Up Lights, Keyless Entry Illumination,

Day/Night Mirror, Turbo Overboost Buzzer

### 6 - 20 Amp

Heated Back Light Control, Deck Lid Release, Electronic Chime

Module, Lights Outage & Clock Display, Cornering & Rear

Reading Lights, Tripminder, Illuminated Entry, Anti-Theft

Module, Radio & Cluster Illumination

### 7 - 15 Amp

Foglights (Turbo Only)

### 8 - 15 Amp

Courtesy & Glove Box Lights, Key Warning Buzzer, Illuminated

Entry Module, Remote Electric Mirrors, Electronic Radio &

Cluster Memories, Anti-Theft Relay & Clock

### 9 - 30 Amp

A/C-Heater Blower Motor

### 10 - 20 Amp



## 1994 Ford Thunderbird LX

FUSES & CIRCUIT BREAKERS '1989-95 FUSES & CIRCUIT BREAKERS Ford Motor Co.

Horn, Cigarette Lighter, Flash-To-Pass Feature, Fuel Filler

Door, Speed Control

### 11 - 20 Amp

Radio, Power Antenna, Sound Amplifier

### 12 - 20-Amp Circuit Breaker

Power Seat & Door Locks, Keyless Entry, Fuel Filler Door Lock

### 13 - 5 Amp

Instrument Cluster, Radio, Climate Control, Instrument Panel

Illumination

### 14 - 20-Amp Circuit Breaker

Power Windows, Power Moon Roof

### 15 - 10 Amp

Taillights, Parking Lights, License & Coach Lights

### 16 - 4 Amp

EATC Memory, Horn, Cigarette Lighter

### 17 - 15 Amp

Electronic Cluster Tripminder, Fuel Gauge, A/C Clutch, Speed

Control Module, Graphic Warning Module

### 18 - 10 Amp

Warning Indicator Lights, Auto Light System, Electronic

Chimes, Low Washer Fluid Light, Low Fuel Module, Throttle

Solenoid Positioner, Low Oil Relay, Tachometer, Flash-To-Pass

Relay

## INTERIOR FUSE PANEL IDENTIFICATION (1989-93 MODELS)



## 1994 Ford Thunderbird LX

FUSES & CIRCUIT BREAKERS '1989-95 FUSES & CIRCUIT BREAKERS Ford Motor Co.

On all models, the fuse panel is located under the instrument panel, left of the steering column.

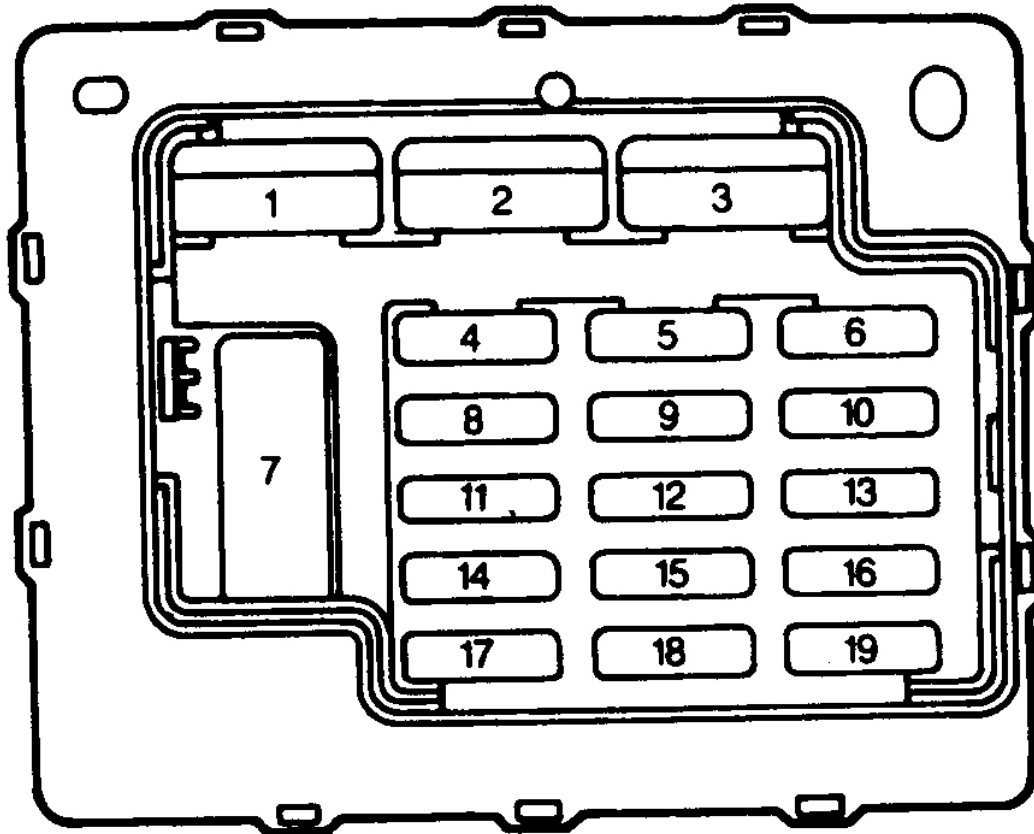

93I44642

**Fig. 2: Interior Fuse Panel Identification (1989-93 Models)**

Courtesy of FORD MOTOR CO.

### Fuse & Circuit Breaker Identification

#### 1 - 20-Amp Circuit Breaker

Deck Lid Solenoid, Power Windows, Moon Roof Motor

#### 2 - 20-Amp Circuit Breaker

Fuel Door Release Solenoid, Power Seats, Power Door Locks

#### 3 - 20-Amp Circuit Breaker

Cigarette Lighter, High Beams



## 1994 Ford Thunderbird LX

FUSES & CIRCUIT BREAKERS '1989-95 FUSES & CIRCUIT BREAKERS Ford Motor Co.

### 4 - 10 Amp

Radio LCD, Auto Light Dim Control, Anti-Theft Module, Chime,

Voltmeter

### 5 - 15 Amp

Power Antenna Motor, Radio, CD Player (89-92)

### 6 - 15 Amp

Stoplights, High Mount Stoplights, Electronic Engine Control

(89-92), Anti-Lock Module (89-92)

### 7 - 8.25-Amp Circuit Breaker

Wiper/Washer Motor, Interval Washer Module

### 8 - 15 Amp

Foglights

### 9 - 10 Amp

Heated Oxygen Sensor (HEGO 1 & 2)

### 10 - 10 Amp

Back-Up Lights, Flasher

### 11 - 30 Amp

Blower Motor

### 12 - 15 Amp

A/C Clutch, Heated Back Light Switch, VMM Module, Coolant

Level Sensor, Electronic Instrument Feed, Electronic

Instrument LCD (89-92), Performance Cluster Ride Light, EVO

Test, Steering Sensor, Ride Control Switch, Ride Control

Module, Ride Control Relay, Washer Level Sensor, Day/Night



## 1994 Ford Thunderbird LX

FUSES & CIRCUIT BREAKERS '1989-95 FUSES & CIRCUIT BREAKERS Ford Motor Co.

Mirror, Parking Brake Light (89-92), Keyless Entry Module,

Daytime Running Lights, Brake Shift Indicator

### 13 - 10 Amp

Anti-Lock Motor Relay Coil

### 14 - 5 Amp

PRNDL Light & VMM, Electronic Instrument Control Switch,

Instrument Panel Illumination, Compact Disc LCD, Radio, Radio

LCD, Ashtray Light, Rear Defrost Switch, A/C Heat Selector

Switch

### 15 - Not Used

### 16 - 10 Amp

License & Rear Park Lights

### 17 - 15 Amp

LCD Illumination Relay, Front Park Lights & Chime, Ride

Control Module, Electronic Climate Control Module, Auto Shock

Module

### 18 - 15 Amp

Instrument Panel & Map Lights, Glove Box & Trunk Lights,

Anti-Theft Light In Cluster, Daytime Running Light Module,

Power Mirrors, Keyless Entry Module, Door Courtesy & Vanity

Lights, "C" Pillar & Dome Lights

### 19 - 10 Amp

Cluster, Chime, Auto Light Sensor, Anti-Lock Module, Cluster

## UNDERHOOD FUSE PANEL IDENTIFICATION (1989-93 MODELS)



## 1994 Ford Thunderbird LX

FUSES & CIRCUIT BREAKERS '1989-95 FUSES & CIRCUIT BREAKERS Ford Motor Co.

The "high-current" fuse panel is located in the engine compartment on the L/H fender apron.

**WARNING:** Always disconnect battery ground cable before servicing "high-current fuses. It is recommended that "high-current" fuses be replaced by a qualified technician.

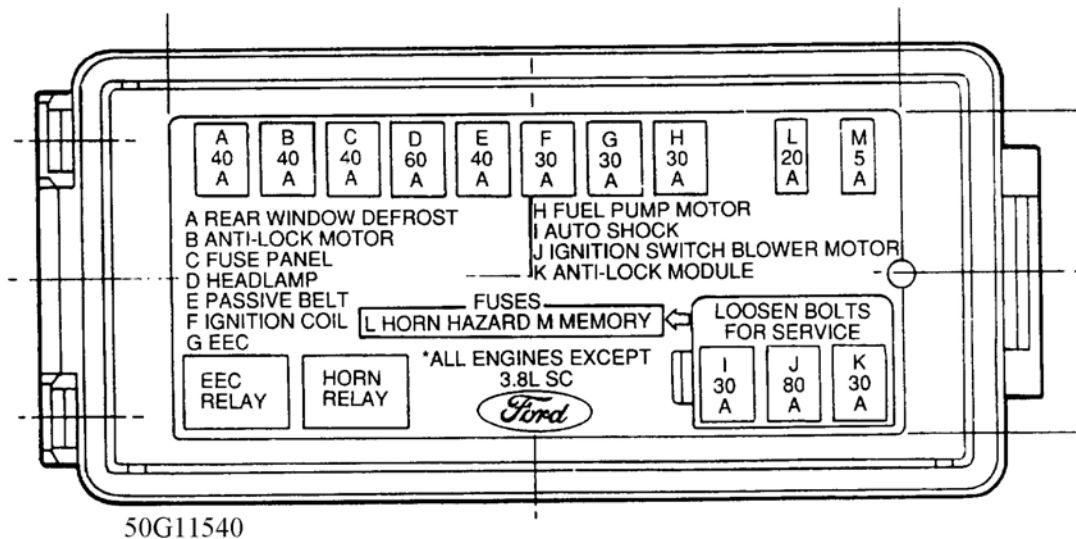

**Fig. 3: Underhood Fuse Panel Identification (1989-93 Models)**  
Courtesy of FORD MOTOR CO.

### Fuse & Relay Identification

**A - 40 Amp**

Rear Window Defroster

**B - 40 Amp**

Anti-Lock Motor

**C - 40 Amp**

Fuse Panel

**D - 60 Amp**

Headlights

**E - 40 Amp**

Passive Restraints

## 1994 Ford Thunderbird LX

FUSES & CIRCUIT BREAKERS '1989-95 FUSES & CIRCUIT BREAKERS Ford Motor Co.

### **F - 30 Amp**

Ignition Coil

### **G - 30 Amp**

Powertrain Control Module (1993), EEC (1989-92)

### **H - 30 Amp**

Fuel Pump Motor

### **I - 30 Amp**

Auto Shock

### **J - 80 Amp**

Ignition Switch, Blower Motor

### **K - 30 Amp**

Anti-Lock Module

### **L - 20 Amp**

Horn/Hazard

### **M - 5 Amp**

Memory

## **INTERIOR FUSE PANEL IDENTIFICATION (1994-95 MODELS)**

On all models, the fuse panel is located under the instrument panel, left of the steering column.





1994 Ford Thunderbird LX

FUSES & CIRCUIT BREAKERS '1989-95 FUSES & CIRCUIT BREAKERS Ford Motor Co.

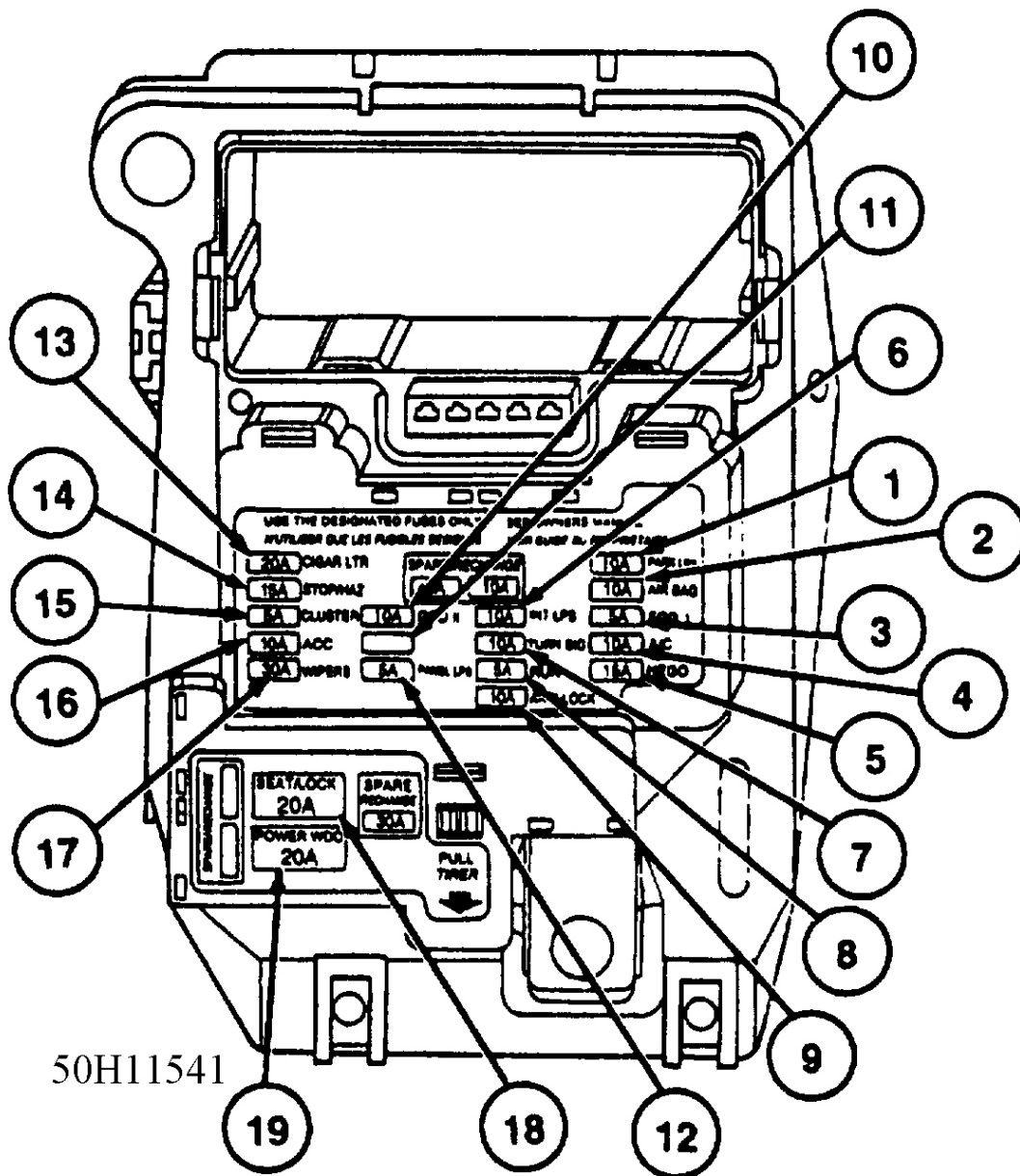

**Fig. 4: Interior Fuse Panel Identification (1994-95 Models)**  
Courtesy of FORD MOTOR CO.

**Fuse & Circuit Breaker Identification**

1 - 10 Amp

Panel Dimmer, Parking/License Lights, Autoshock Module, Clock

2 - 10 Amp



## 1994 Ford Thunderbird LX

FUSES & CIRCUIT BREAKERS '1989-95 FUSES & CIRCUIT BREAKERS Ford Motor Co.

Air Bag Module

**3 - 5 Amp**

Foglight Switch

**4 - 10 Amp**

A/C Clutch

**5 - 15 Amp**

HEGO 1 & 2 (V6 Only)

**6 - 10 Amp**

Anti-Theft, Trunk, Map, Vanity, Glove Box, Underhood,

L/H Instrument Panel, Rear Courtesy, Door Courtesy, Lock

Cylinder & Dome Lights, Power Mirrors

**7 - 10 Amp**

Turn Signal Indicators/Lights, Backup Lights

**8 - 5 Amp**

Cluster, Rear Defrost Switch, Coolant/Wash Level Sensor,

DRL Module, EVO Test, EVO Steering Sensor, ARC (EVO) Module,

ARC Switch, Hard Relay, Soft Relay, Auto Mirror, EATC Blend

Door, Airbag Module, Overdrive Cancel Switch, Brakeshift

Solenoid

**9 - 10 Amp**

Main ABS Relay, ABS Module

**10 - 10 Amp**

OBD-II Test Connector

**11 - Not Used**



## 1994 Ford Thunderbird LX

FUSES & CIRCUIT BREAKERS '1989-95 FUSES & CIRCUIT BREAKERS Ford Motor Co.

### 12 - 5 Amp

Illumination Of: Cluster, Phone Switch, Rear Defrost Switch,  
A/C Switch (Manual), PRNDL Indicator, Ashtray, EATC, Clock,  
Radio

### 13 - 20 Amp

Cigarette Lighter, Flash-To-Pass

### 14 - 15 Amp

Speed Control Module, ABS Module, BrakeShift Interlock,  
High Mount Brakelight, Brakelights, Flashers

### 15 - 5 Amp

Cluster (Gauges), Cluster (ABS & Airbag Warning),  
Warning Chime, Autolight Sensor

### 16 - 10 Amp

Integrated Module, Sport Voltmeter, Speed Control, Remote  
Keyless Entry, Anti-Theft, Power Window/Door Lock Switch  
Illumination, Radio, CD Changer, Power Antenna, Clock

### 17 - 30 Amp

Wiper/Washer System

### 18 - 20 Amp

Power Door Locks, Decklid Release, Fuel Door Release,  
Power Seats, Power Lumbar, Booster

### 19 - 20 Amp

Power Window Motors, Moon Roof Motor

## UNDERHOOD FUSE PANEL IDENTIFICATION (1994 MODELS)



## 1994 Ford Thunderbird LX

FUSES & CIRCUIT BREAKERS '1989-95 FUSES & CIRCUIT BREAKERS Ford Motor Co.

The "high-current" fuse panel is located in the engine compartment on the L/H fender apron.

**WARNING:** Always disconnect battery ground cable before servicing "high-current" fuses. It is recommended that "high-current" fuses be replaced by a qualified technician.

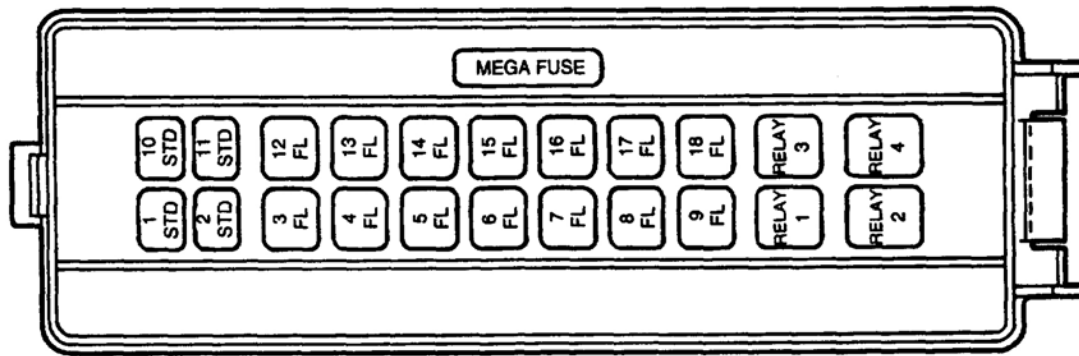

50I11542

**Fig. 5: Underhood Fuse Panel Identification (1994-95 Models)**  
Courtesy of FORD MOTOR CO.

### Fuse & Relay Identification

#### 1 - 15 Amp

DRL Module, Foglights

#### 2 - 5 Amp

Memory

#### 3 - 20 Amp

Ignition Coil

#### 4 - 20 Amp

Auto Shock

#### 5 - 60 Amp

Engine Fan

#### 6 - 40 Amp

Anti-Lock Brake System Motor



## 1994 Ford Thunderbird LX

FUSES & CIRCUIT BREAKERS '1989-95 FUSES & CIRCUIT BREAKERS Ford Motor Co.

### 7 - 60 Amp

Headlights

### 8 - 20 Amp

Anti-Lock Brake System Module

### 9 - 60 Amp

Ignition Switch

### 10 - 15 Amp

Horn

### 11 - 15 Amp

Generator

### 12 - 40 Amp

Fuse Panel

### 13 - 20 Amp

Fuel Pump

### 14 - 40 Amp

Rear Defrost

### 15 - 20 Amp

Electronic Engine Control Module

### 16 - 30 Amp

Pusher Fan

### 17 - 60 Amp

Blower Motor

### 18 - Not Used

Mega Fuse - 175 Amp



**1994 Ford Thunderbird LX**

FUSES & CIRCUIT BREAKERS '1989-95 FUSES & CIRCUIT BREAKERS Ford Motor Co.

Power Distribution Box

**Relay 1**

Horn (1994), Not Used (1995)

**Relay 2**

Power (1994), Horn (1995)

**Relay 3**

Anti-Lock Brake System (1994), Not Used (1995)

**Relay 4**

Foglights (1994), Anti-Lock Brake System (1995)

