

Control Arm: Service and Repair Replacing Bracket For Control Arm

Replacing Both Control Arm Brackets

Caution!

If a bracket is replaced, a new bracket must also be installed on the other side.
After installation, check freedom of movement of other components to control arm bracket.
If necessary, bend back heat shield and cut panel.

Remove engine underguard and if necessary heat shield on right.
Remove reinforcement (cross).
Remove reinforcement (plate).

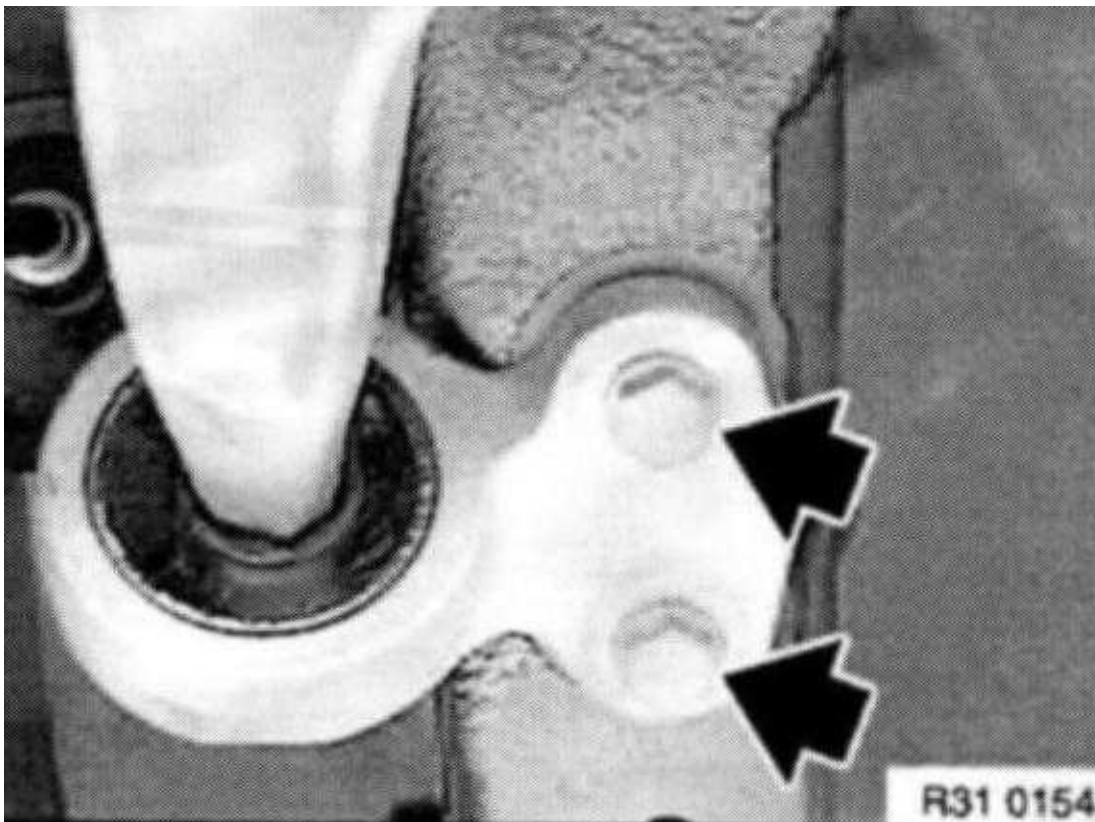

Unfasten screws.

Installation:

Control arm holder to engine carrier 59 Nm

Note: Replace Screws.

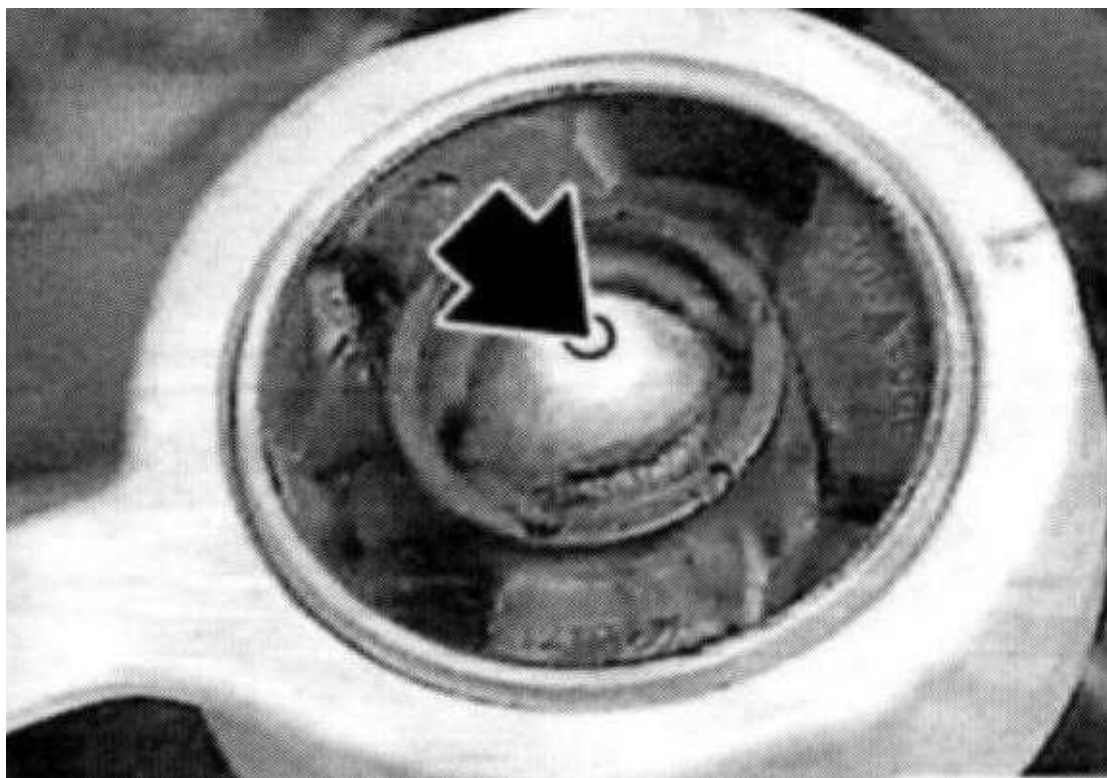

Punch-mark center of control arm.

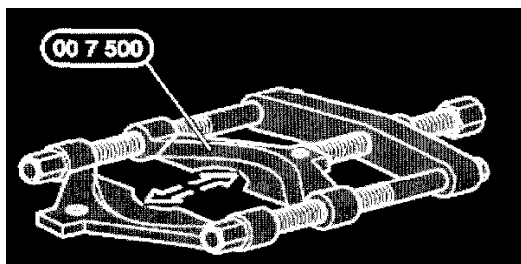

Composite parts of special tool 00 7 500.

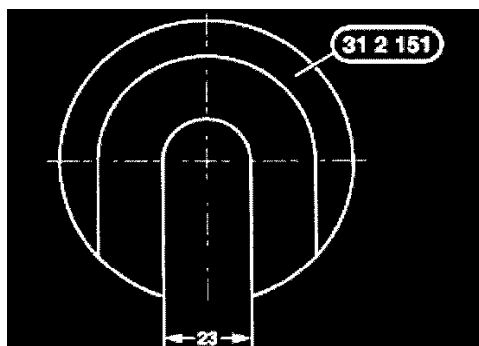

If necessary, remachine special tool 31 2 151 as per drawing.

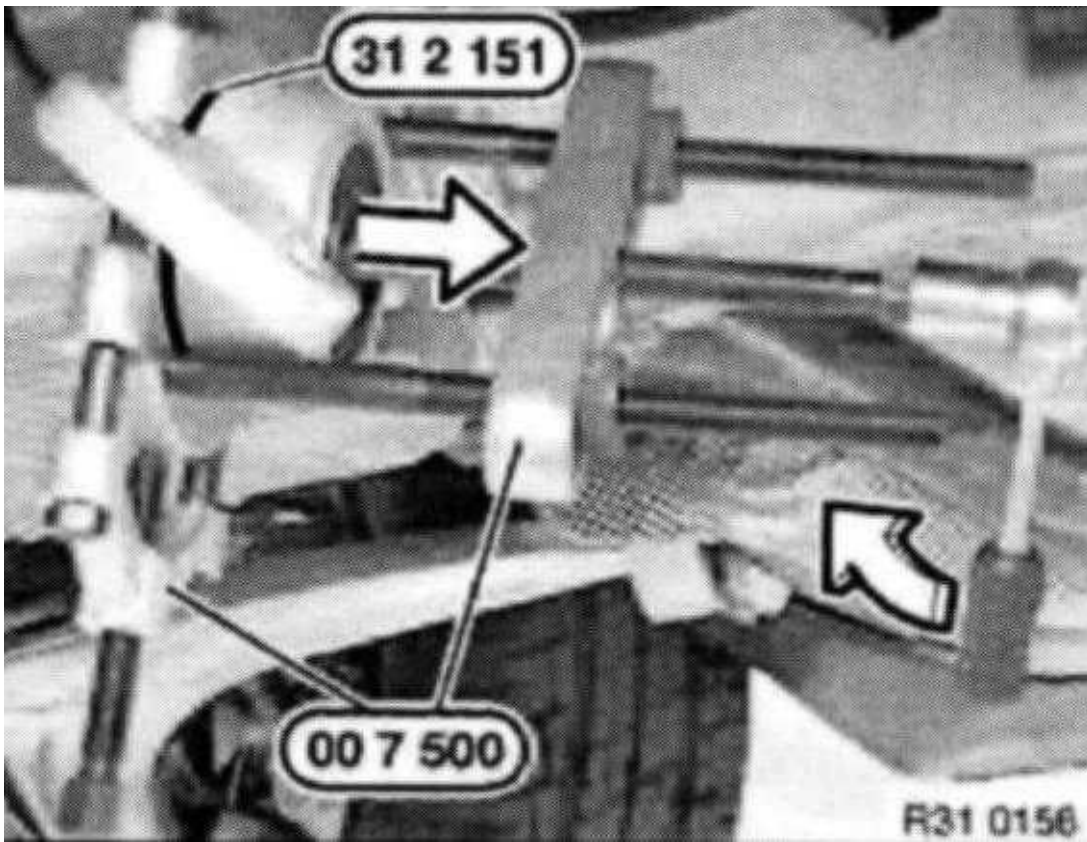

Detach bracket with special tool 00 7 500/31 2 151 from control arm.

Caution!

Never re-use a rubber mount pulled off from control arm.
Rubber-coated inner sleeve is destroyed if pulled off dry.

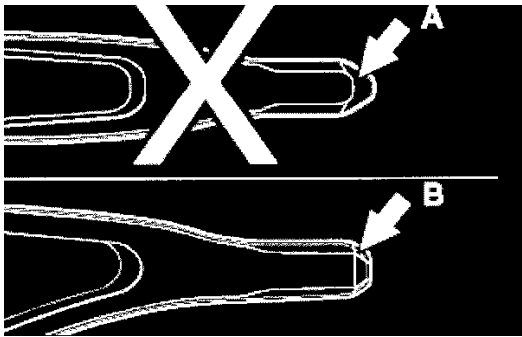

Caution!

A control arm with pin shape (A) must be replaced! Only control arms with pin shape (B) may be fitted!

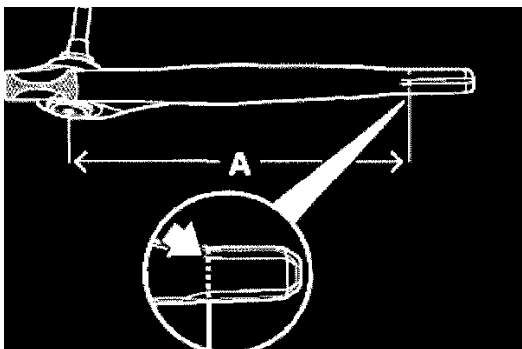

Mark out measurement (A) at bottom at control arm pin.
A=290.9 ± 1 mm

Installation:

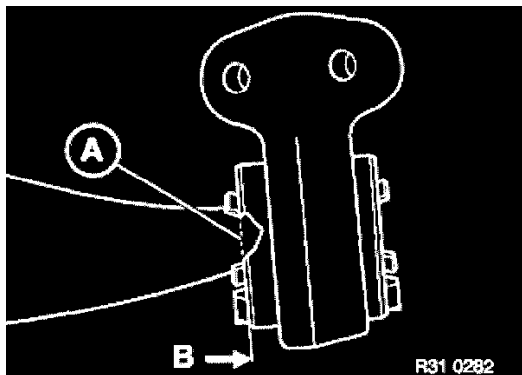

Outer edge (B) of rubber mount must be flush with marked measurement (A).

Caution!
If the position of the rubber mount is not strictly adhered to, this will result in impaired vehicle handling and early rubber mount wear!

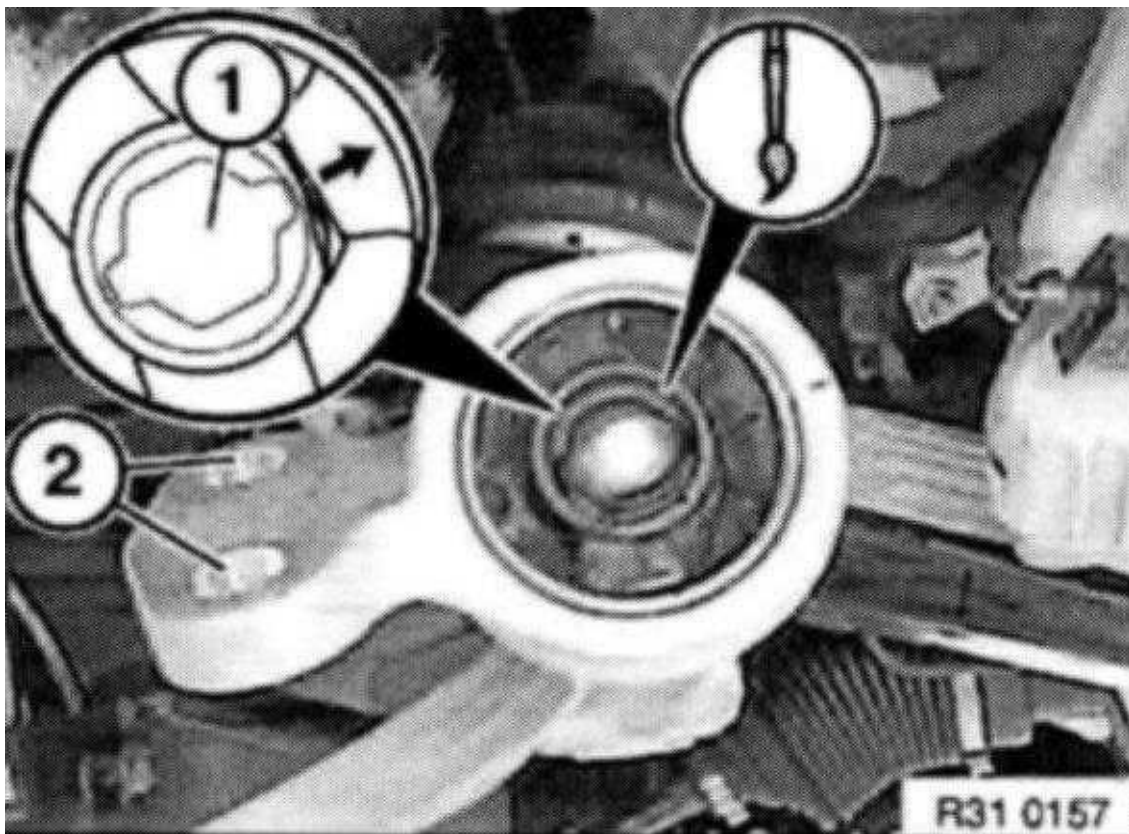

Coat control arm pin and rubber mount bushing with low surface-tension water. Mixture ratio:
1 part soap to 20 parts water.
Ensure positive locking (1) of bushing and control arm pin.
The larger diameters of the bores (2) point to the engine support.

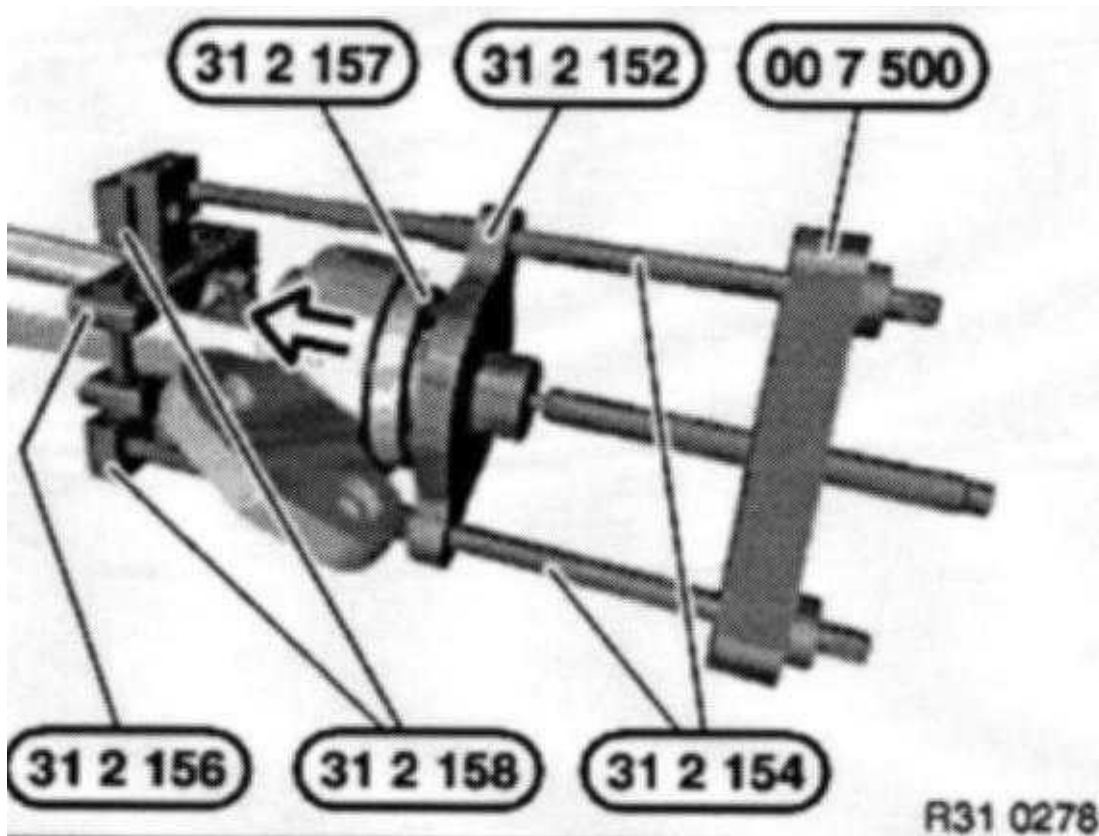

Control arm without opening:

Screw special tools 31 2 156/158 onto control arm until hand-tight.

Pull new bracket onto control arm up to marking with special tool 00 7 500 and 31 2 152/154/157.

Relieve tension on special tool. Check position of rubber mount to marking (measurement A) and correct if necessary.

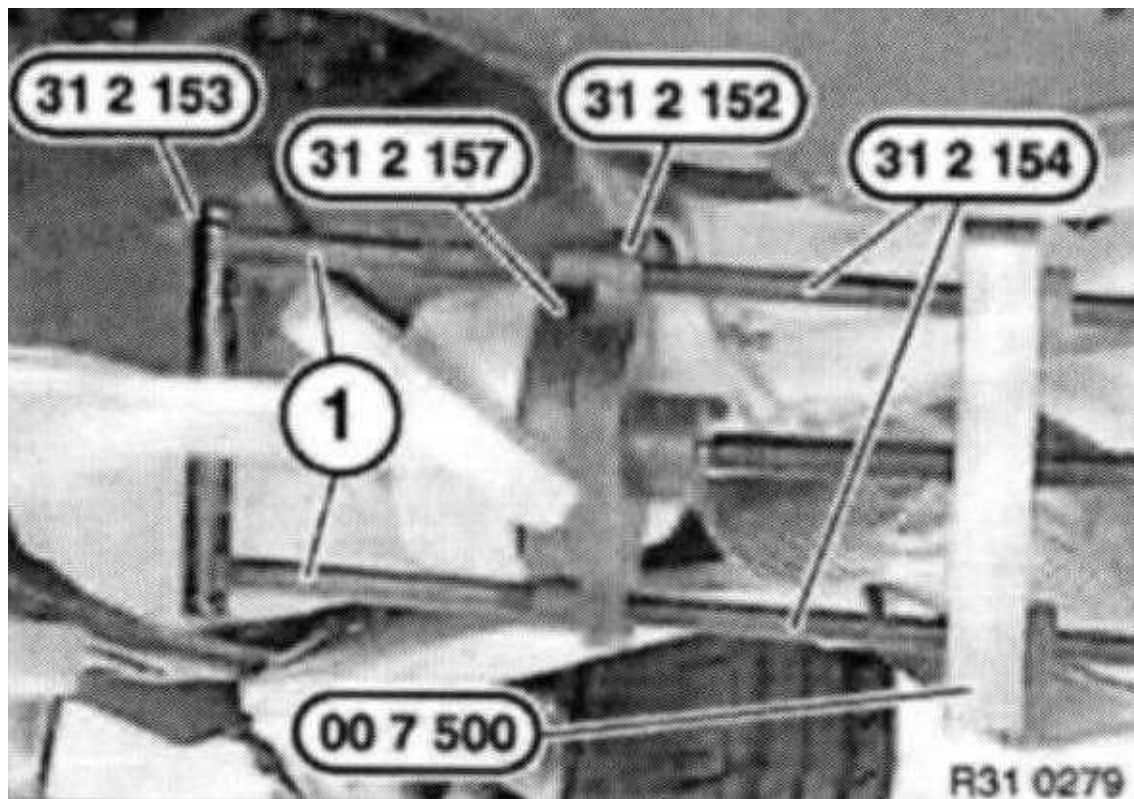

Control arm with opening:

Attach special tool 31 2 153 with extensions (1) from puller set to control arm opening.

Pull new bracket onto control arm up to marking with special tool 00 7 500 and 31 2 152/154/157.

Relieve tension on special tool. Check position of rubber mount to marking (measurement A) and correct if necessary.