

#08-07-30-027: No Movement When Transmission is Shifted to Drive or Third - Normal Operation When Shifted to Second, First or Reverse (Replace Forward Sprag Assembly) - (Jun 4, 2008)

Subject: No Movement When Transmission is Shifted to Drive or Third - Normal Operation When Shifted to Second, First or Reverse (Replace Forward Sprag Assembly)



Models: 1982-2005 GM Passenger Cars and Light Duty Trucks
 2006-2007 Buick Rainier
 2006 Cadillac Escalade, Escalade ESV, Escalade EXT
 2006 Chevrolet SSR
 2006-2008 Chevrolet Avalanche, Colorado, Express, Silverado Classic, Silverado, Suburban, Tahoe, TrailBlazer
 2006 GMC Yukon Denali, Yukon Denali XL
 2006-2008 GMC Canyon, Envoy, Savana, Sierra Classic, Sierra, Yukon, Yukon XL
 2006 Pontiac GTO
 2006-2007 HUMMER H2
 2006-2008 HUMMER H3
 2006-2008 Saab 9-7X
 with 4L60, 4L60E, 4L65E or 4L70E Automatic Transmission (RPOs MD8, M30, M32, M33 or M70)

Condition

Some customers may comment that the vehicle has no movement when the transmission is shifted to DRIVE or THIRD position, but there is normal operation when it is shifted to SECOND, FIRST or REVERSE position.

Cause

This condition may be caused by a damaged forward sprag assembly (642).

Correction

When inspecting the sprag, it is important to test the sprag for proper operation by holding the outer race (644) with one hand while rotating the input sun gear (640) with the other hand. The sun gear should rotate only in the counterclockwise direction with the input sun gear facing upward. If the sprag rotates in both directions or will not rotate in either direction, the sprag elements should be inspected by removing one of the sprag assembly retaining rings (643). Refer

© 2010 General Motors. All rights reserved.

to SI Unit Repair section for forward clutch sprag disassembly procedures.

If the sprag is found to be damaged, make repairs to the transmission as necessary. A new forward roller clutch sprag assembly is now available from GMSP0.

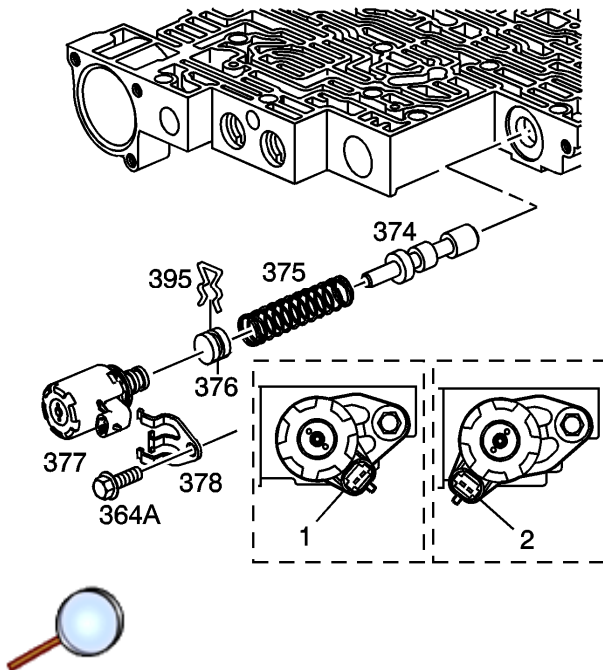

If clutch debris is found, it is also very important to inspect the Pressure Control (PC) solenoid valve (377) fluid screens. Clean or replace the PC solenoid (377) as necessary. It is also important to flush and flow check the transmission oil cooler using J45096. Refer to SI Automatic Transmission Oil Cooler Flushing and Flow Test for the procedure.

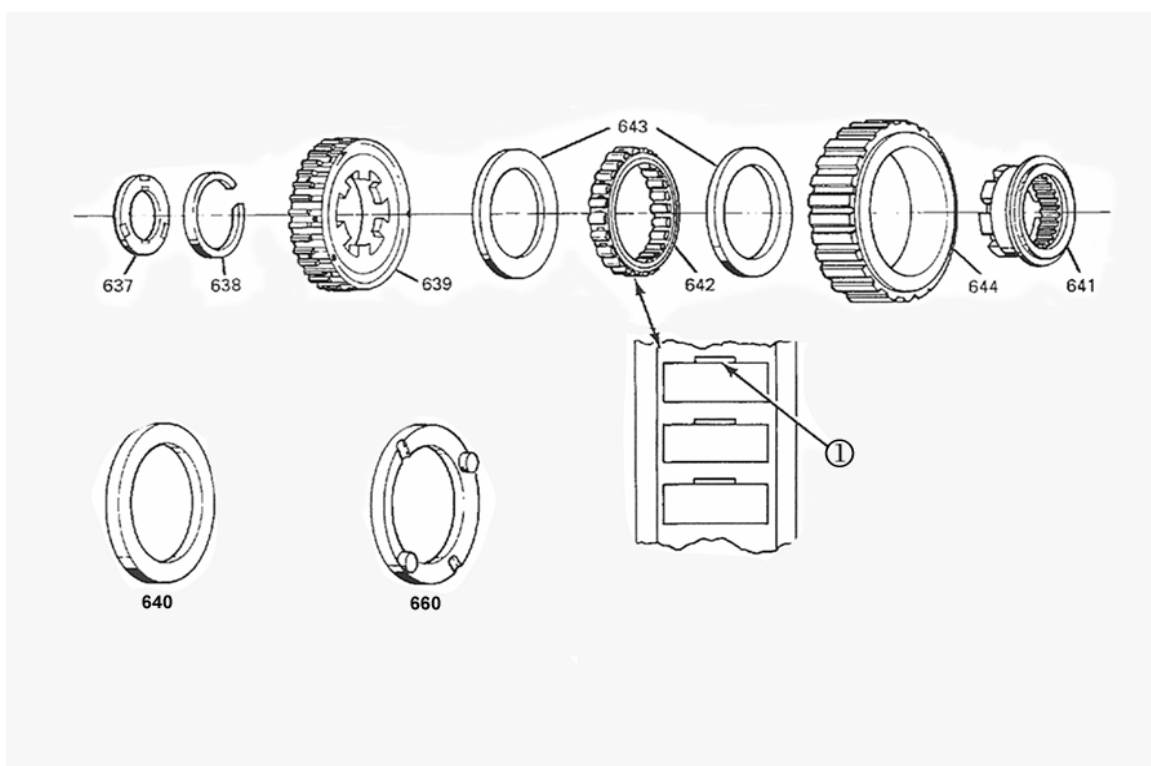

(1) The notches above each sprag must point up as shown when assembled into the outer race.

- (637) Bearing Assembly, Input Sun Gear
- (638) Snap Ring, Overrun Clutch Hub Retaining
- (639) Hub, Overrun Clutch
- (640) Wear Plate, Sprag Assembly
- (641) Retainer and Race Assembly, Sprag
- (642) Forward Sprag Assembly
- (643) Retainer Rings, Sprag Assembly
- (644) Outer Race, Forward Clutch
- (660) Washer, Thrust (Input Carrier to Race)

The following information applies when this sprag is used in 1982-86 transmissions.

The new design sprag can be used on models 1982 through 1986, by replacing the entire assembly (637 -- 644). Individual components are *NOT* interchangeable.

Important: The wear plate (640) and input thrust washer (660) are not required with the new sprag. Use of the thrust washer and wear plate with the new sprag assembly will cause a misbuild (correct end play cannot be obtained).

Parts Information

Part Number	Description
24241477	Sprag, Forward Clutch

Warranty Information

For vehicles repaired under warranty, use:

Labor Operation	Description	Labor Time
K7253	Sprag, Forward Clutch -- Replace	Use Published Labor Operation Time

GM bulletins are intended for use by professional technicians, NOT a "do-it-yourselfer". They are written to inform these technicians of conditions that may occur on some vehicles, or to provide information that could assist in the proper service of a vehicle. Properly trained technicians have the equipment, tools, safety instructions, and know-how to do a job properly and safely. If a condition is described, DO NOT assume that the bulletin applies to your vehicle, or that your vehicle will have that condition. See your GM dealer for information on whether your vehicle may benefit from the information.



WE SUPPORT
VOLUNTARY
TECHNICIAN
CERTIFICATION