



[Home](#) | [Account](#) | [Contact ALLDATA](#) | [Log Out](#) | [Help](#)

RACEWAY FORD

Select Vehicle | New TSBs | Technician's Reference | Component Search:

OK

Conversion Calculator

1984 Lincoln Town Car V8-302 5.0L

[Vehicle Level](#) → [Body and Frame](#) → [Doors, Hood and Trunk](#) → [Front Door Panel](#) → [Service and Repair](#)

Service and Repair

[Notes](#)

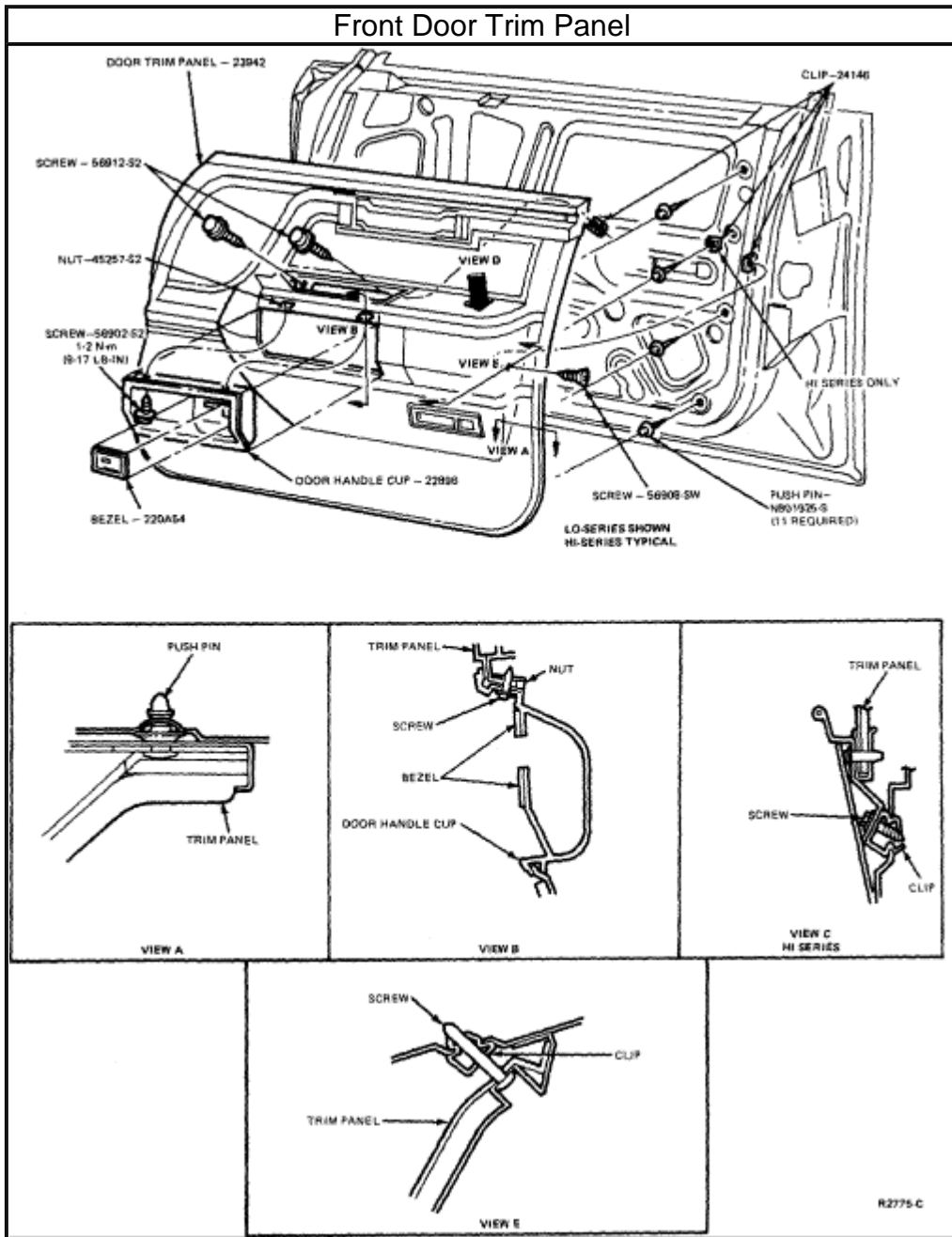

Zoom

Sized for Print

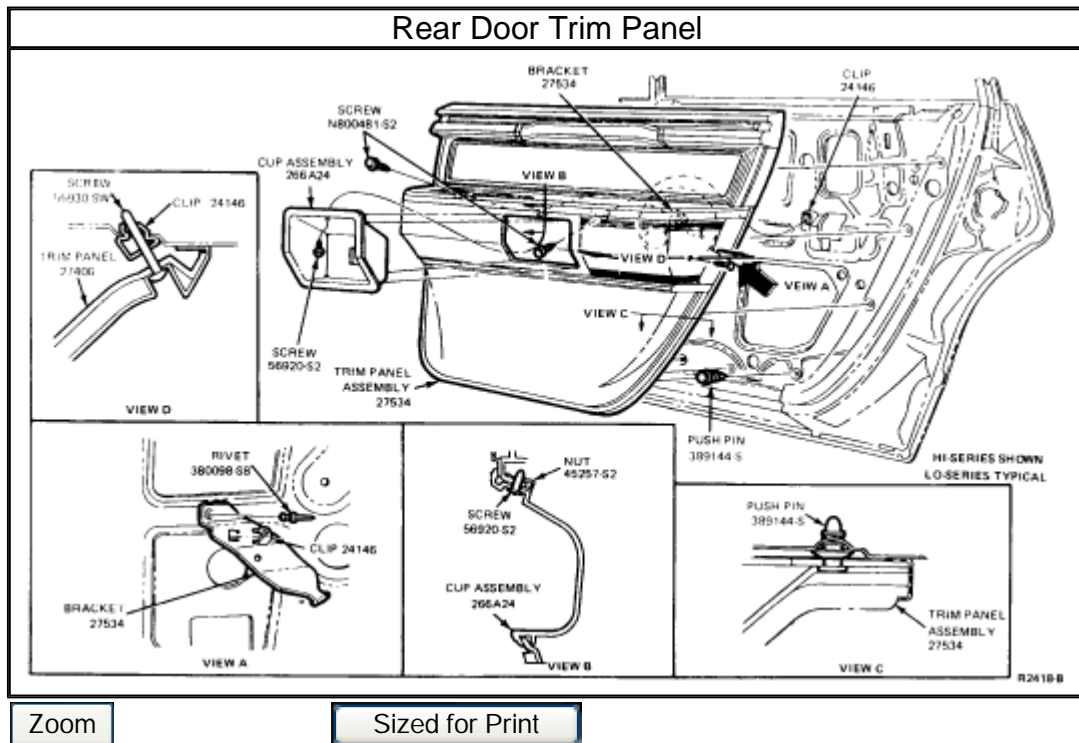

Removal

Note: During service, disconnect the remote rod-to-lock knob assembly prior to lifting off the housing plate to avoid possible damage to the lock knob assembly.

The following procedure must be used during removal and installation of the door armrest and [trim panel](#). Refer to the appropriate illustrations for component identification.

1. Remove the retaining screws from the door inside handle cup assembly. If equipped with armrest courtesy lamps, remove the lens, detach the bulb and wiring assembly from the pull cup and remove the pull cup.

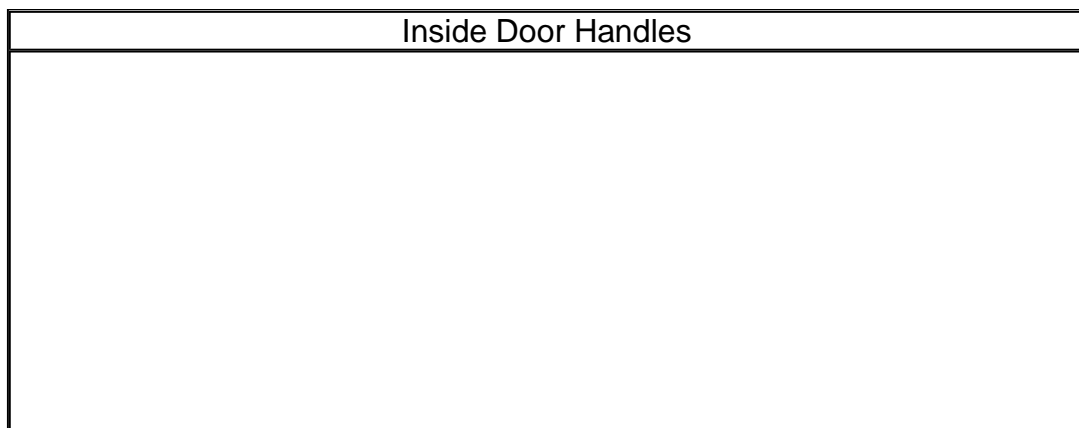

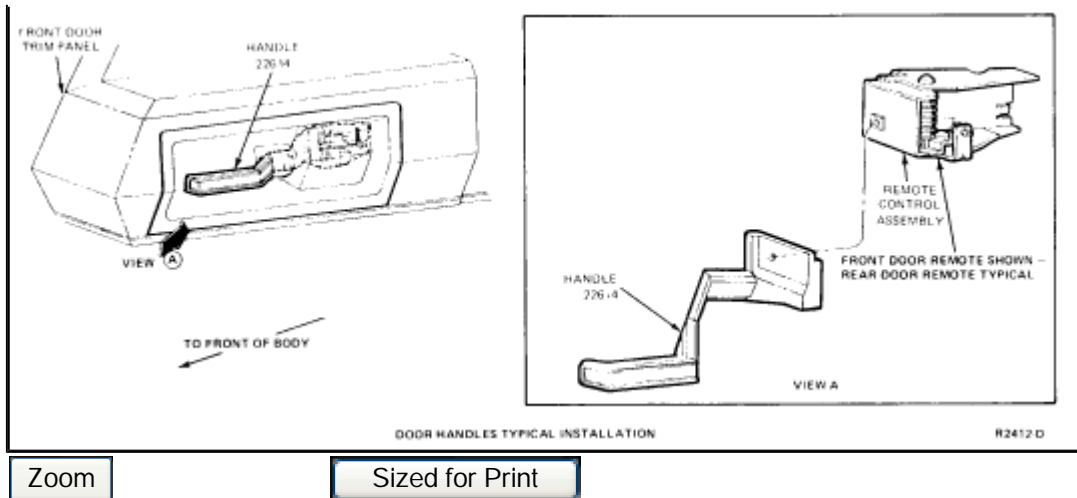

2. Disconnect the remote lock rod from the lock knob assembly. Gain access through pull cup opening.
3. Using a putty knife or similar tool, carefully pry window switch bezel from armrest.

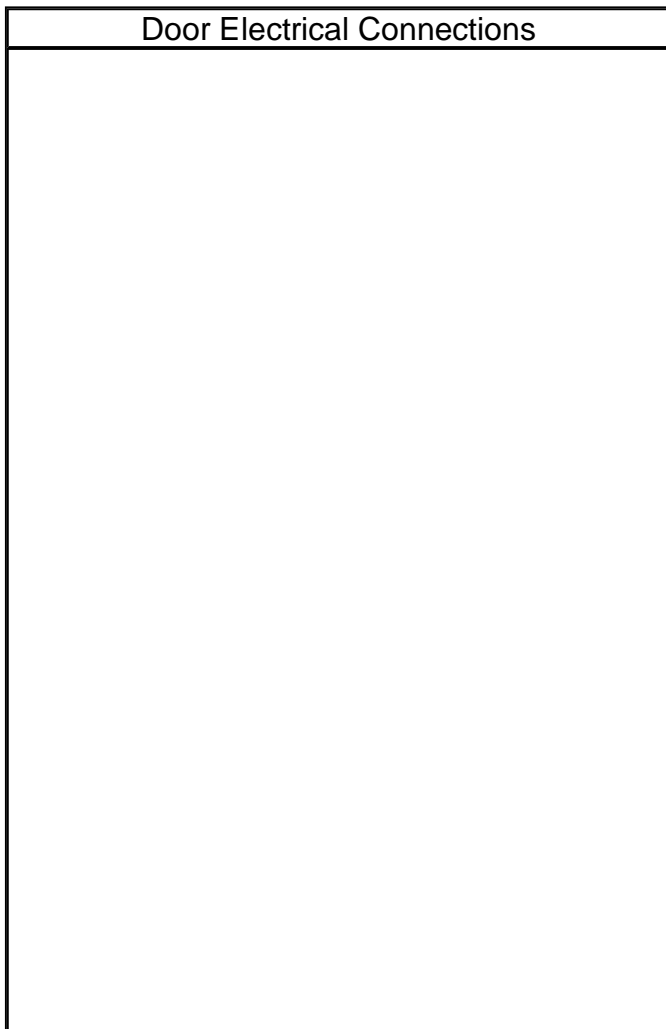

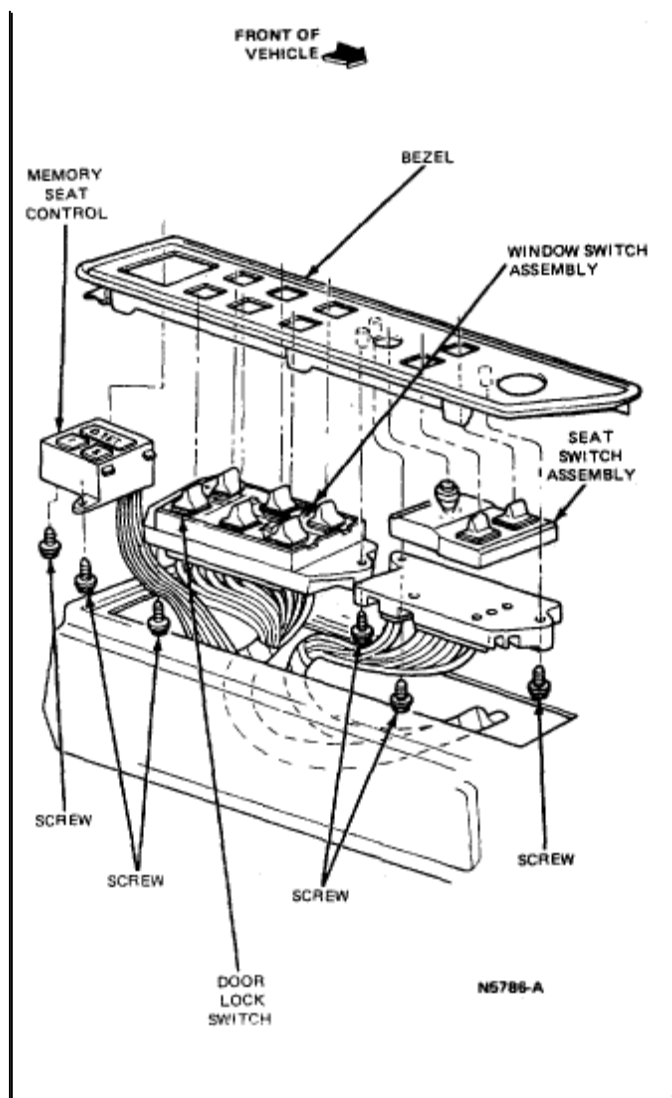

Zoom

Sized for Print

4. Remove the retaining screw and the remote mirror bezel nut from the power window regulator housing switch plate and raise the plate to expose the window switch and [power door lock switch](#), if so equipped, and disconnect.

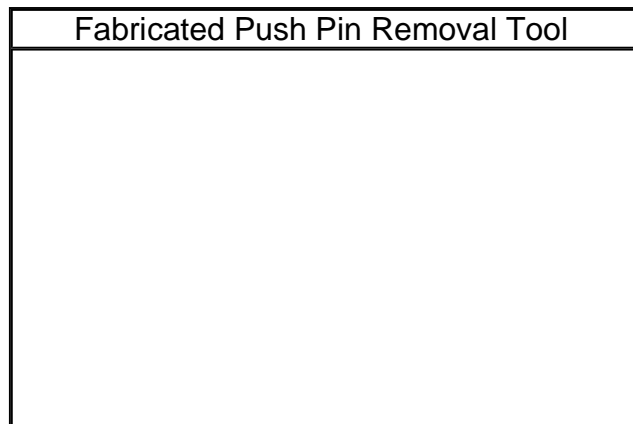

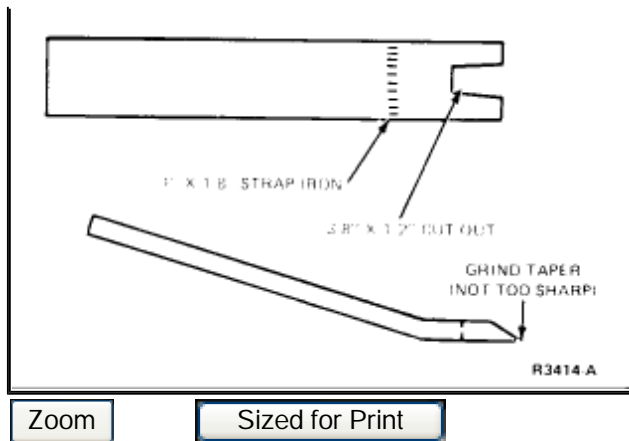

5. With a fabricated push pin removal tool (as shown) or Using the Trim Pad Removing Tool from Rotunda Moulding/Trim Kit 107-00401 or equivalent, carefully pry the [trim panel](#) plastic push pin retainers from the door inner panel. **Note:** Do not use [trim panel](#) to pry clips from door inner panel. Replace any bent, damaged or missing push pins.
6. Disconnect the radio speaker wiring, if so equipped. Remove [trim panel](#) and watershield.

Installation

1. If [trim panel](#) requires replacement, transfer plastic push pins to the new panel. Ensure that the watershield is positioned correctly to the door sheet metal.
2. Position the [trim panel](#) loosely to the door belt opening and route the wiring harness through the appropriate access holes in the trim panel. Connect the radio speaker, if so equipped.
3. Align plastic push pins on [trim panel](#) to the holes in the door sheet metal and press pins into place.
4. Install the power window regulator switch plate housing to the armrest connecting the power window switch, [power door lock switch](#), and remote mirror bezel nut, prior to securing the retainer screw.
5. Connect the lock remote rod to the lock knob assembly retainer boss. **Note:** Ensure that the remote rod is fully seated into the retainer boss, then function manually or with the power switch to ensure smooth operation of the lock knob assembly.
6. Install bulb and wiring assembly. Install lamp lens, if so equipped, and the pull cup assembly.