

CAMSHAFTS

NOTE: When servicing camshafts, reference to right and left components are as viewed from rear (flywheel end) of engine.

Removal

1. For access to valve covers, air intake chamber and intake air connector must be removed. See **Fig. 11** .
2. Remove air cleaner hose along with upper cap on air cleaner and mass airflow meter. Disconnect necessary electrical connectors, control cables, vacuum hoses and coolant hoses for removal of air intake chamber with throttle body.
3. On models with EGR, remove nuts, EGR pipe and gaskets. On all models, remove bolts and air intake chamber support brace from air intake chamber. Remove bolts/nuts, air intake chamber and gasket.
4. Disconnect necessary electrical connectors, ground straps, vacuum hoses and wiring brackets for removal of intake air connector. Remove bolts/nuts, intake air connector and gasket.
5. Disconnect necessary electrical connectors and wiring clamps for removal of engine wiring harness assembly for access to valve covers. Remove bolts, ignition coils with spark plug wires from valve covers. Remove bolts, seal washers, valve covers and gaskets.
6. Remove timing belt and camshaft sprockets. See **TIMING BELT** under REMOVAL & INSTALLATION. Remove bolts, camshaft position sensor, rear timing belt cover and gaskets. See **Fig. 15** .
7. To service camshafts in right cylinder head, align timing marks with 2 dots on camshaft gears by rotating camshaft using hexagonal area of camshaft. See **Fig. 25** . To service camshafts in left cylinder head, align timing marks with one dot on camshaft gears by rotating camshaft using hexagonal area of camshaft. See **Fig. 25** .

1997 Toyota 4Runner Limited

3.4L V6 '1997-98 ENGINES Toyota 3.4L V6

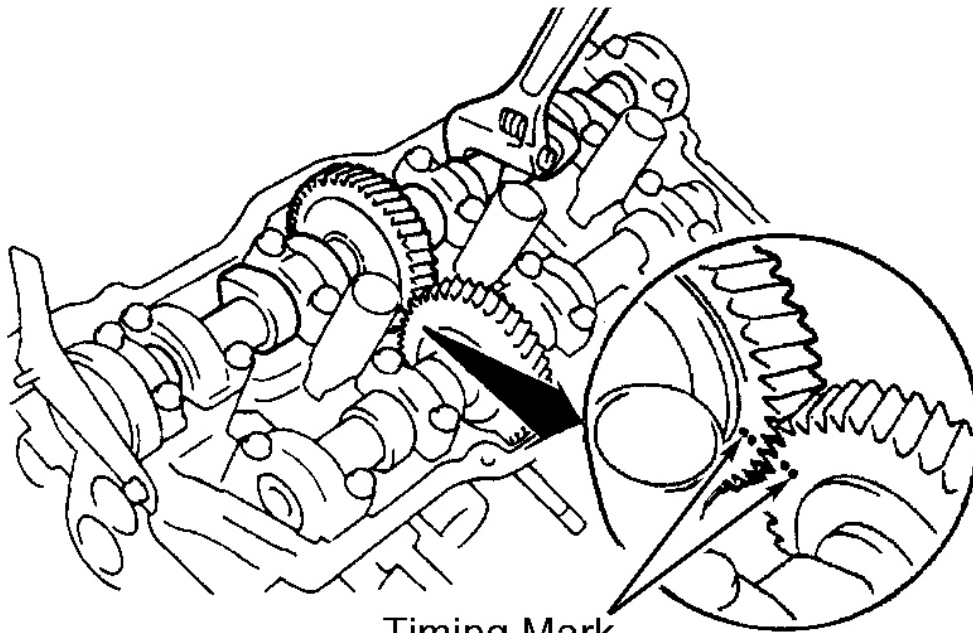

Timing Mark
(2 Dots)

RIGHT CYLINDER HEAD

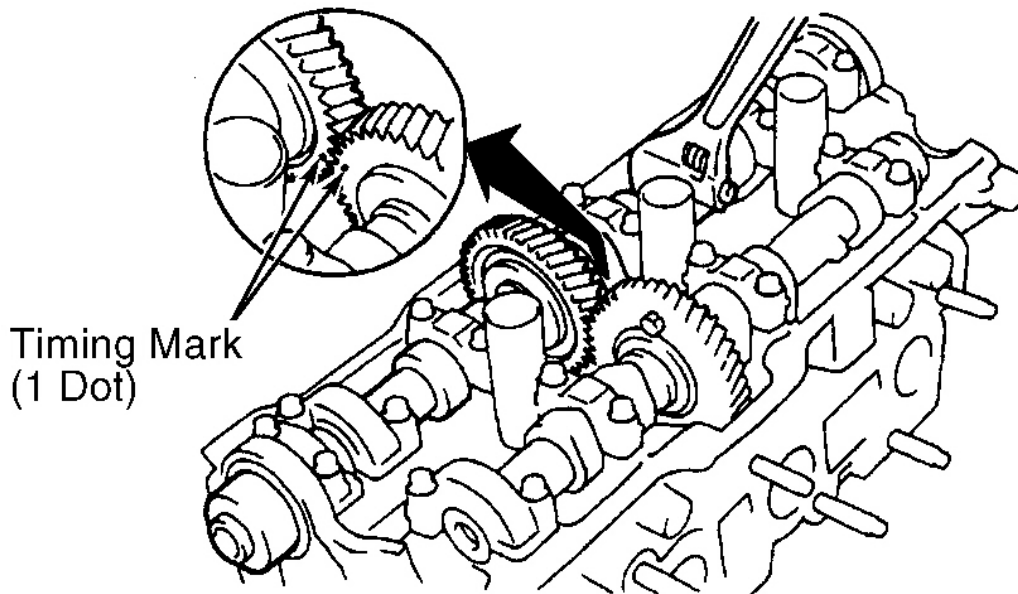

Timing Mark
(1 Dot)

LEFT CYLINDER HEAD

G97108038

Fig. 25: Aligning Camshaft Timing Marks

Courtesy of TOYOTA MOTOR SALES, U.S.A., INC.

8. On all applications, secure camshaft sub-gear on exhaust camshaft to main gear with a 6 x 1.0 x 18-mm service bolt. See **Fig. 26** . Before removing camshaft bearing cap bolts, ensure torsional spring force of camshaft sub-gear is held by service bolt.

NOTE: Camshaft bearing caps are numbered for location on top of camshaft bearing cap. Camshaft bearing cap is also stamped with either an "I" for intake camshaft or an "E" for exhaust camshaft. Arrow on top of camshaft bearing cap must point the proper direction in accordance with cylinder head application. See **Fig. 27** . Camshaft bearing caps must be installed in correct location.

9. Note location of camshaft bearing caps, as camshaft bearing caps are numbered for location on top of camshaft bearing cap. Camshaft bearing cap is also stamped with either an "I" for intake camshaft or an "E" for exhaust camshaft. Arrow on top of camshaft bearing cap must point the proper direction in accordance with cylinder head application. See **Fig. 27** .

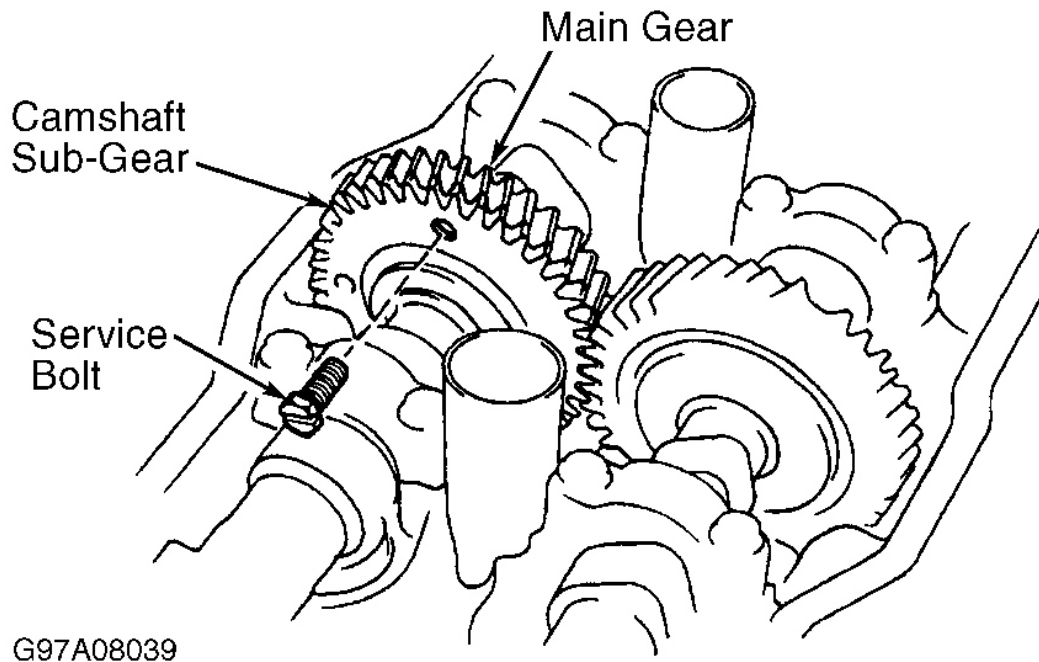
**Fig. 26: Installing Service Bolt To Secure Camshaft Sub-Gear (Right Cylinder Head Shown; Left Cylinder Head Similar)**

Courtesy of TOYOTA MOTOR SALES, U.S.A., INC.

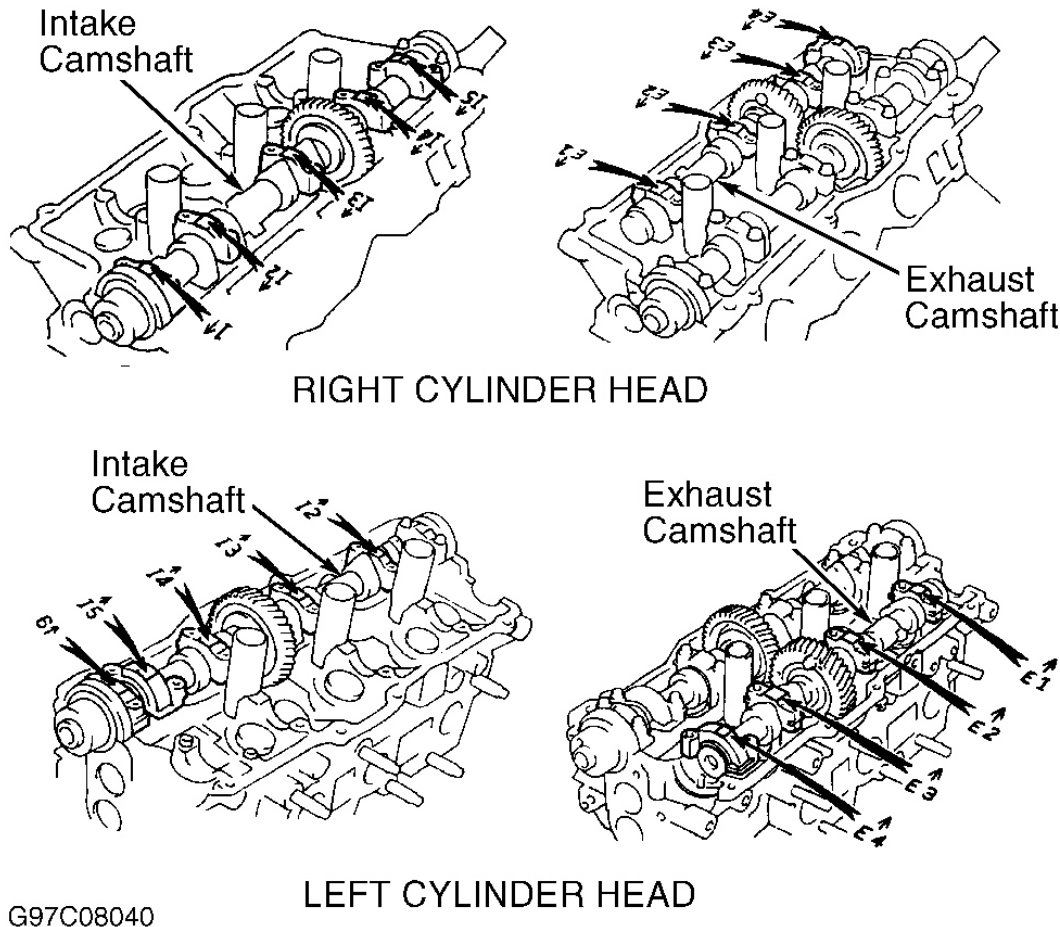

G97C08040

Fig. 27: Identifying Camshaft Bearing Caps
 Courtesy of TOYOTA MOTOR SALES, U.S.A., INC.

CAUTION: Camshaft bearing cap bolts must be removed in proper sequence to prevent damage to cylinder head and camshaft thrust surfaces.

10. Remove exhaust camshaft bearing cap bolts in sequence using several steps. See **Fig. 28** . Remove camshaft bearing caps and exhaust camshaft.
11. Remove intake camshaft bearing cap bolts in sequence using several steps. See **Fig. 28** . Remove camshaft bearing caps, intake camshaft and oil seal.
12. If disassembling exhaust camshaft, mount hexagonal area of camshaft in soft-jawed vise. Using Spanner Wrench (SST 09960-10010), rotate camshaft sub-gear clockwise and remove service bolt. See **Fig. 29** . Remove snap ring, wave washer, camshaft sub-gear and camshaft gear spring. See **Fig. 13** .

1997 Toyota 4Runner Limited

3.4L V6 '1997-98 ENGINES Toyota 3.4L V6

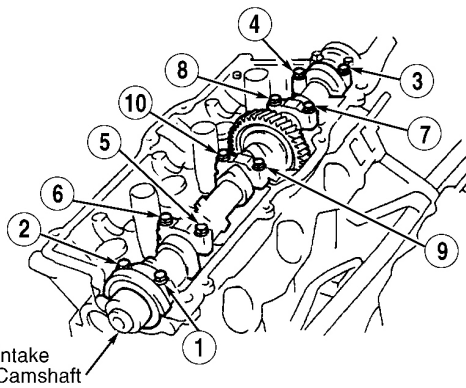
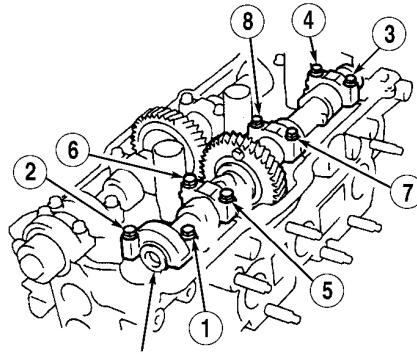
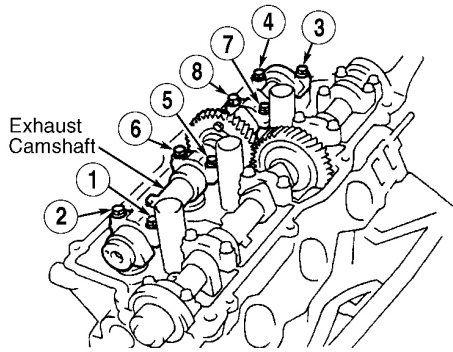

RIGHT CYLINDER HEAD

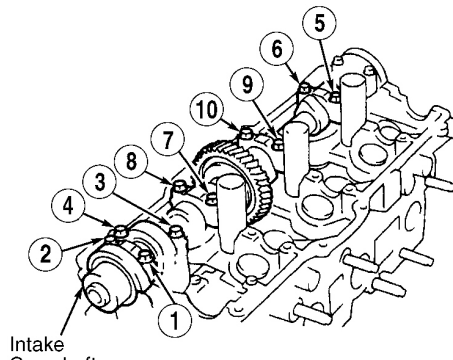

LEFT CYLINDER HEAD

G97C08361

Fig. 28: Camshaft Bearing Cap Bolt Removal Sequence
Courtesy of TOYOTA MOTOR SALES, U.S.A., INC.

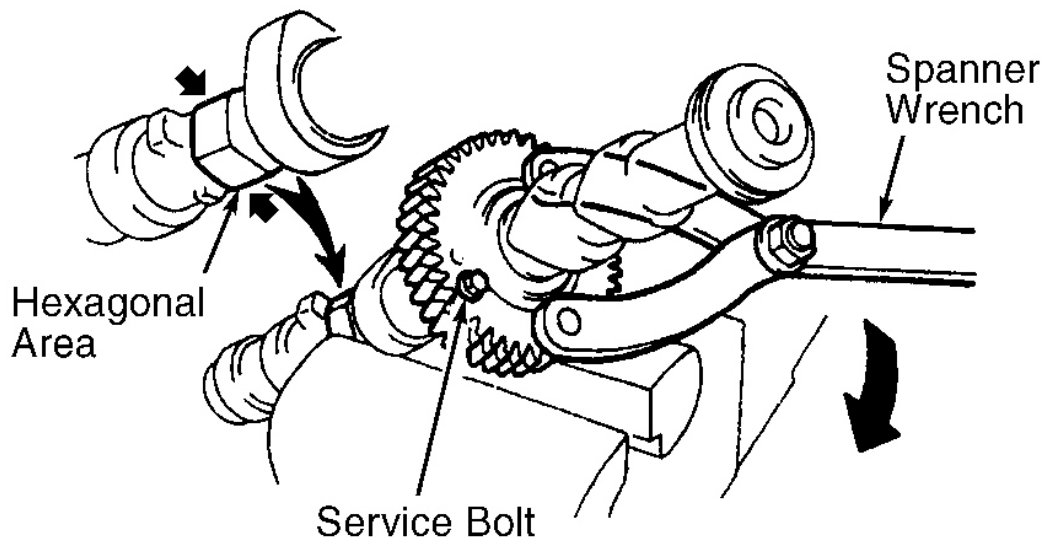

G97E08362

Fig. 29: Disassembling & Reassembling Exhaust Camshaft
 Courtesy of TOYOTA MOTOR SALES, U.S.A., INC.

Inspection

1. Inspect components for damage. Check camshaft journal diameter, lobe height and journal runout. Replace camshaft if not within specification. See **CAMSHAFT** under ENGINE SPECIFICATIONS.
2. Install camshaft in cylinder head. Using Plastigage, check camshaft oil clearance. Tighten camshaft bearing cap bolts to specification in sequence when checking oil clearance. See **Fig. 31** . See **TORQUE SPECIFICATIONS** .
3. Replace camshaft and/or cylinder head if oil clearance is not within specification. See **CAMSHAFT** under ENGINE SPECIFICATIONS.
4. Check camshaft end play with camshaft bearing cap bolts tightened to specification. Replace camshaft and/or cylinder head if end play is not within specification. See **CAMSHAFT** under ENGINE SPECIFICATIONS.
5. Install both camshafts without camshaft sub-gear installed on exhaust camshaft. Tighten camshaft bearing cap bolts to specification. Check gear backlash between camshaft gears.
6. Replace camshaft if gear backlash exceeds specification. See **CAMSHAFT** under ENGINE SPECIFICATIONS. Measure distance between ends of camshaft gear spring. Replace camshaft gear spring if distance is not .716-.740" (18.20-18.80 mm).

Installation

1. If reassembling exhaust camshaft, install camshaft gear spring and camshaft sub-gear on exhaust camshaft. Ensure pins on camshaft sub-gear engage with ends of camshaft gear spring. Install wave

washer and snap ring on exhaust camshaft.

2. Using spanner wrench, rotate camshaft sub-gear clockwise until holes in main gear and camshaft sub-gear are aligned. Temporarily install service bolt. See **Fig. 29** . Ensure gear teeth of main gear and camshaft sub-gear are aligned. Tighten service bolt.
3. Apply engine oil to thrust surfaces and journals of camshafts. Install intake camshaft on cylinder head. Rotate intake camshaft so timing mark with 2 dots on right cylinder head applications or timing mark with one dot on left cylinder head applications is properly positioned with surface on cylinder head. See **Fig. 30** .

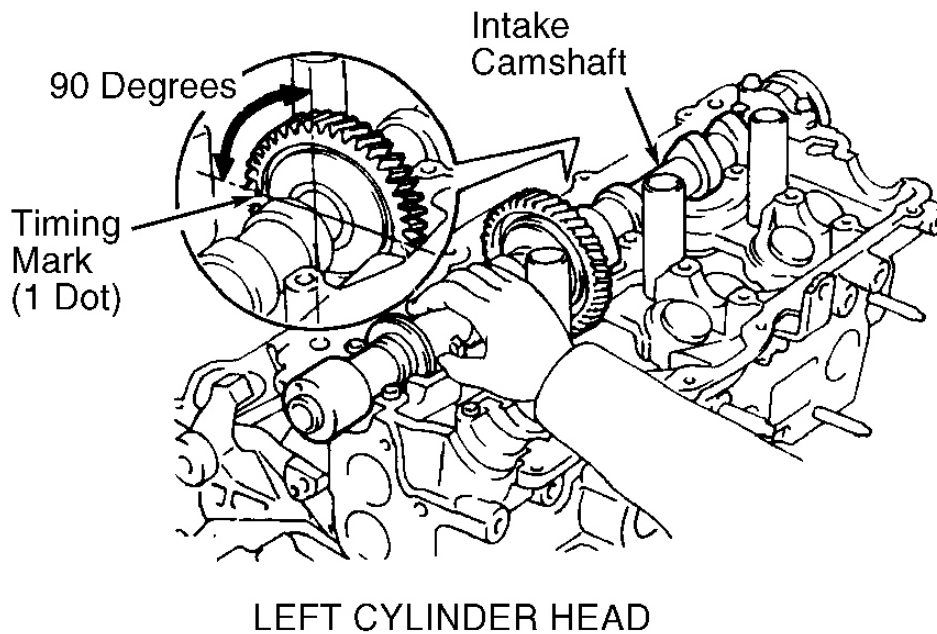
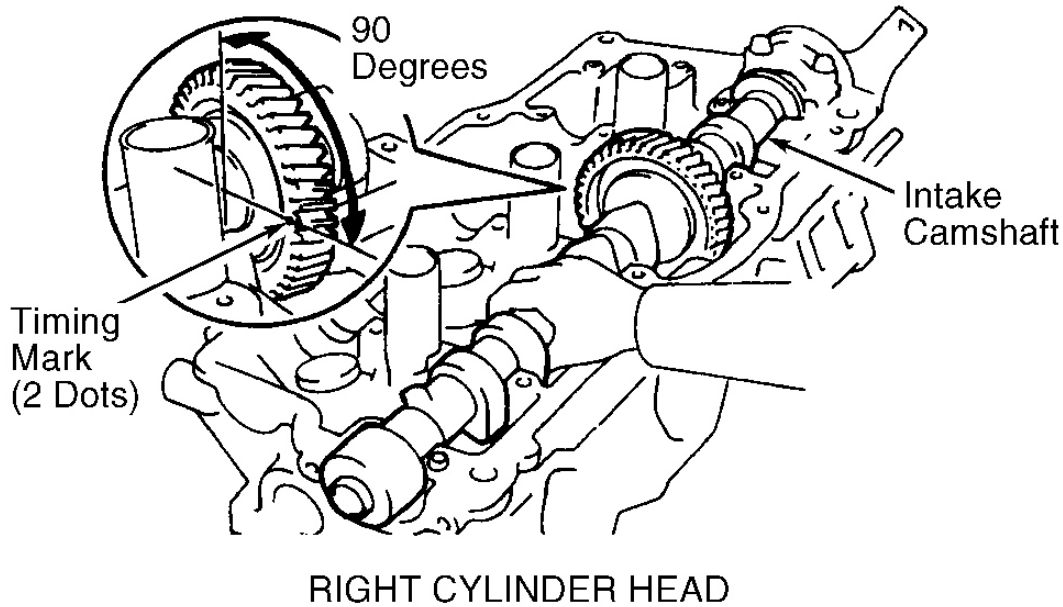

G97G08363

Fig. 30: Installing Intake Camshaft On Cylinder Head
Courtesy of TOYOTA MOTOR SALES, U.S.A., INC.

4. Apply engine oil to seal lip on NEW oil seal. Install oil seal on intake camshaft. Apply sealant on No. 1 intake camshaft bearing cap at bearing cap-to-cylinder head surface.
5. Install intake camshaft bearing caps in numerical order. Ensure arrow on top of camshaft bearing cap is

pointing toward proper direction in accordance with cylinder head application. See **Fig. 27** .

6. Coat camshaft bearing cap bolt-to-camshaft bearing cap surface and bolt threads with engine oil. Install and tighten intake camshaft bearing cap bolts to specification in sequence using several steps. See **Fig. 31** . See **TORQUE SPECIFICATIONS** .

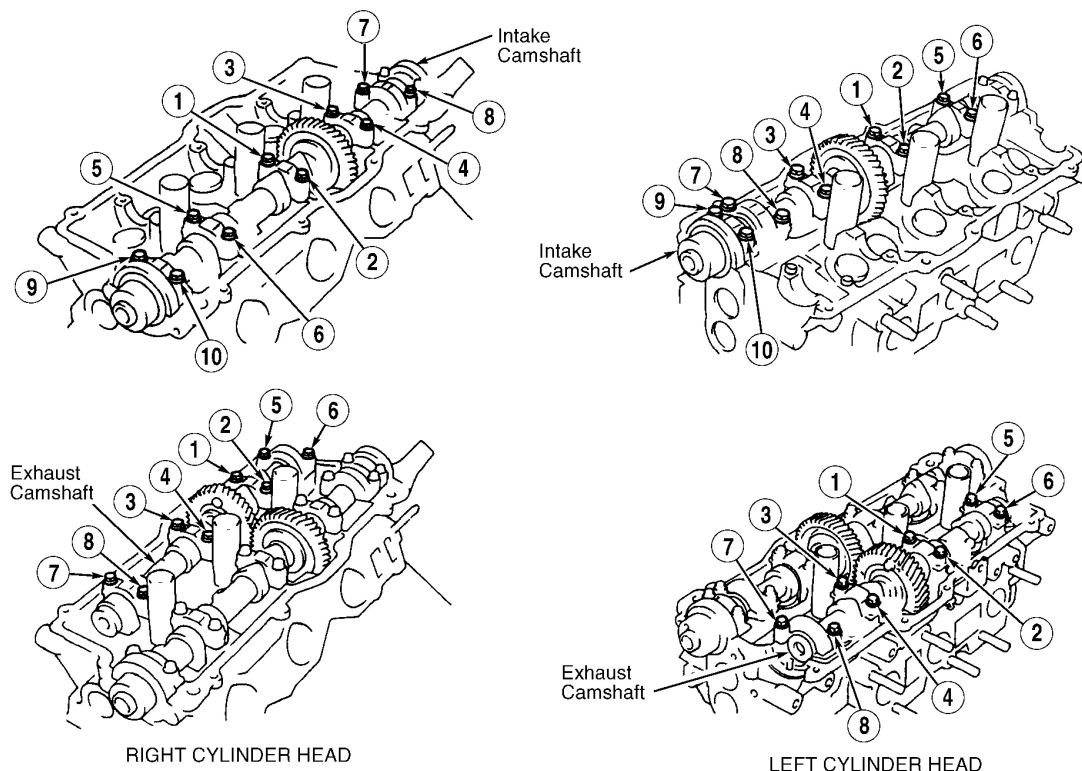

G97108364

Fig. 31: Camshaft Bearing Cap Bolt Installation Sequence
 Courtesy of TOYOTA MOTOR SALES, U.S.A., INC.

7. Install exhaust camshaft on cylinder head so timing marks with 2 dots on right cylinder head applications or timing mark with one dot on left cylinder head applications is aligned with timing mark on intake camshaft. See **Fig. 25** .
8. Install exhaust camshaft bearing caps in numerical order. Ensure arrow on top of camshaft bearing cap is pointing toward proper direction in accordance with cylinder head application. See **Fig. 27** .
9. Coat camshaft bearing cap bolt-to-camshaft bearing cap surface and bolt threads with engine oil. Install and tighten exhaust camshaft bearing cap bolts to specification in sequence using several steps. See **Fig. 31** . See **TORQUE SPECIFICATIONS** .

CAUTION: Ensure service bolt is removed from camshaft sub-gear on exhaust camshafts.

10. On all cylinder head applications, remove service bolt from exhaust camshaft. Check and adjust valve

clearance. See **VALVE CLEARANCE ADJUSTMENT** under ADJUSTMENTS.

11. Apply sealant to grooves of semi-circular plugs and install in cylinder head (if removed). See **Fig. 13** . Before installing valve cover and gasket, apply sealant at front and rear areas of the cylinder head. See **Fig. 7** .
12. Using NEW gasket, install valve cover. Install and tighten valve cover bolts to specification in several steps. See **TORQUE SPECIFICATIONS** .
13. To install remaining components, reverse removal procedure using NEW gaskets. Tighten bolts/nuts to specification. See **TORQUE SPECIFICATIONS** .
14. When installing camshaft position sensor, ensure pin on camshaft position sensor engages with hole in cylinder head. Install timing belt using proper procedure. See **TIMING BELT** under REMOVAL & INSTALLATION. Fill cooling system.